

SCOTT

McCULLOCH CORPORATION
6101 West Century Blvd.
Los Angeles 45, California

CONDENSED SERVICE DATA

Series	3.6 Hp Model
Year Produced	
1955	3.6 Bail-A-Matic
1956	Sportster
1957	3075
1958	3085
1959	130A
1960	A388
1961	61300310
1962	62300310
1963	63300311
	63300411

TUNE-UP	
Hp @ rpm	3.6 @ 4000
Bore—Inches	2 1/4
Stroke—Inches	1 1/4
Number of Cylinders	1
Displacement—Cu. In.	6.23
Spark Plug	
Champion	H10F
Electrode Gap	0.035
Magneto	
Point Gap	0.020
Timing	See Text
Carburetor	
Make	Tillotson
Model	AJ16A
Adjustment	See Text
Fuel—Oil Ratio	24:1

SIZES—CLEARANCES	
Cylinder—Diameter	See Note
Piston Rings	
End Gap	
Side Clearance	
Piston to Cylinder Clearance	
Piston Pin Diameter	
Crankshaft Journal Diameters	
Top Main Bearing	
Lower Main Bearing	
Crankpin	

NOTE: Publication not authorized by manufacturer.

TIGHTENING TORQUES	
(All Values in Inch-Pounds)	
Connecting Rod	75
Crankcase Halfes	70
Crankcase to Cylinder	80
Cylinder Head	80
Power Head to Lower Unit	75-85
Flywheel Nut	400
Spark Plug	250
Transfer Passage Cover	30
Inlet Manifold	30
Head valve to plate	8-11
Gearcase to driveshaft housing	135
Gearcase bearing cap	70

LUBRICATION

The power head is lubricated by oil mixed with the fuel. Three-eighths (3/8) pint of two-cycle engine oil should be mixed with each gallon of unleaded gasoline. If outboard motor oil is not available, a good grade of regular (Type MM) SAE 30 engine oil may be substituted. Regular gasoline may be used instead of unleaded gasoline, however the antiknock components may shorten spark plug life. Mix gasoline and oil thoroughly, using a separate container, before pouring mixture into fuel tank.

The lower unit gears and bearings are lubricated by oil contained in the gear case. Only outboard gear (water-proof) lubricant should be used. Use a pressure oil can with rubber seal on spout, remove upper (vent) plug and lower (drain) plug from gearcase, and with motor in upright position, fill through lower plug hole until lubricant reaches level of upper (vent) plug hole. Reinstall vent plug, remove oil can, then reinstall lower plug. Tighten both plugs securely, using new gaskets if necessary, to ensure a water-tight seal. Lubricant should be maintained at level of vent plug and drained and renewed at least once each year.

FUEL SYSTEM

CARBURETOR. All models before 1963 are equipped with a Tillotson AJ16A carburetor similar to that shown exploded in Fig.

M-1. Later models use a Walbro LMG-153 carburetor. Refer to Fig. M-1A for exploded view. Adjustment and service procedures are outlined in the appropriate following paragraphs.

Tillotson Carburetor: The carburetor has slow-speed and high-speed mixture adjust-

ment needles. Refer to Fig. M-1. Normal initial setting of the main adjustment needle (MN) is approximately 1 full turn from closed position. Slow-speed mixture needle (IN) should be approximately 1/2-3/4 turns open. Final adjustment should be made under load after the motor is warm. Clockwise

Fig. M-1—Exploded view of Tillotson AJ carburetor typical of that used on 3.6 horsepower motors.

- IN, Idle needle
- MN, Main needle
- 1, Pinat cover
- 2, Retaining clip
- 3, Float
- 4, Inlet valve seat
- 5, Inlet needle
- 6, Spacers
- 7, Spring
- 8, Choke button
- 9, Air deflector
- 10, Knob
- 11, Packing nut
- 12, Packing
- 13, Plug
- 14, Synchronizer lever
- 15, Retainer screw
- 16, Pivot pin
- 17, Idle tube
- 18, Stop lever
- 19, Throttle valve
- 20, Body
- 21, Plug
- 22, Throttle shaft
- 23, Spring

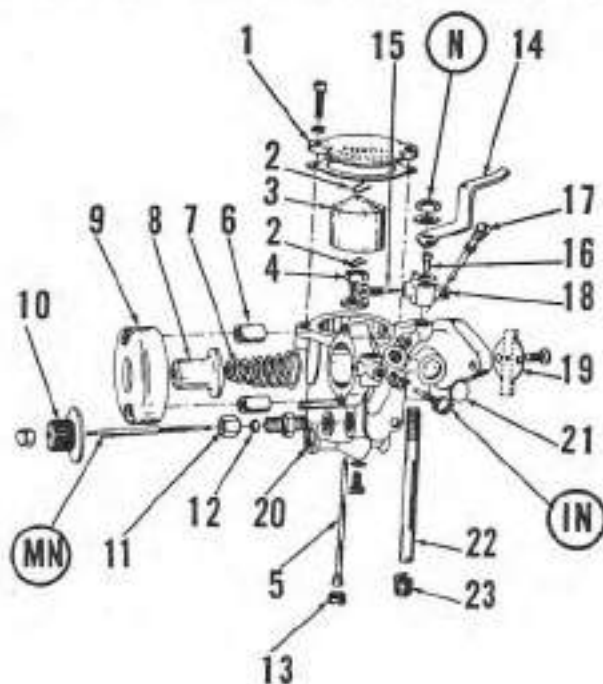

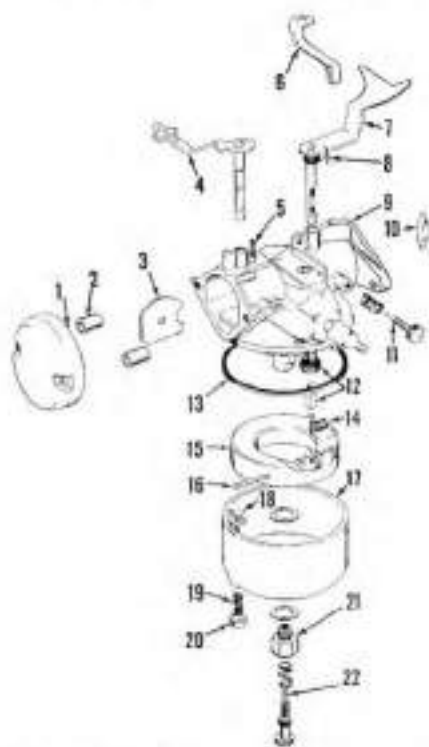

Fig. Mc1A — Exploded view of the Walbro Model LM6159 carburetor used on late models.

- | | |
|------------------------|--------------------------|
| 1. Air deflector | 12. Inlet needle valve |
| 2. Spacer | 13. Gasket |
| 3. Choke valve | 14. Float spring |
| 4. Choke shaft | 15. Float |
| 5. Positioning spring | 16. Float shaft |
| 6. Actuator | 17. Float bowl |
| 7. Throttle shaft | 18. Drain valve |
| 8. Return spring | 19. Valve spring |
| 9. Carburetor body | 20. Retainer |
| 10. Throttle valve | 21. Bowl nut |
| 11. Idle mixture screw | 22. Main fuel adjustment |

rotation of the main needle (MN); or counter-clockwise rotation of the idle needle (IN); leans the mixture.

To disassemble the carburetor, first disconnect fuel line and remove carburetor from inlet manifold. Remove air deflector (9), choke button (8) and spring (7). To disassemble the float, first remove float cover (1) and lower plug (13). Remove upper clip (2) from inlet needle and carefully push needle down flush with top of float. Remove float (3) and lower clip (2); then remove inlet needle (5) downward out of carburetor. Inlet needle valve seat (4) can be removed from top side of carburetor bowl after inlet needle has been removed. Reassemble by reversing the disassembly procedure, making sure clips (2) are in place in grooves in inlet needle (5). Float is non-adjustable.

Tillotson repair parts are as follows:

- | | |
|---------------------------|--------|
| Repair kit | BK-214 |
| Gasket set | GS-112 |
| Inlet needle & seat | 05941 |

Walbro Carburetor: The carburetor is provided with slow-speed and high-speed mixture needles. Refer to Fig. Mc1A. Initial setting of both the slow-speed mixture needle

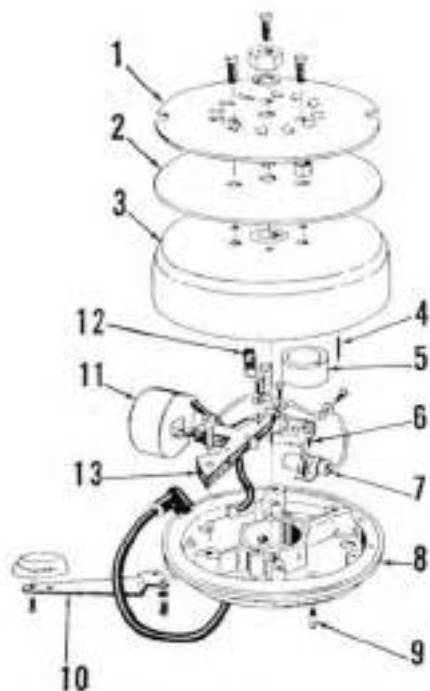

Fig. Mc2 — Exploded view of magneto assembly used on 3.6 horsepower motors.

- | | |
|------------------------|-------------------------|
| 1. Hatchet plate | 8. Stator plate |
| 2. Plate | 9. Synchronizer pin |
| 3. Flywheel | 10. Speed control lever |
| 4. Key | 11. Coil |
| 5. Cam | 12. Friction screw |
| 6. Breaker point Assy. | 13. Coil laminations |
| 7. Condenser | |

(11) and high-speed mixture needle (22) is 1 1/4 turns open from closed position. Final adjustment must be made under load after motor is warm. Clockwise rotation of either needle leans the mixture.

To disassemble the carburetor, disconnect fuel line and remove carburetor from power head. Remove high-speed mixture needle and bowl nut (21) as an assembly, then lift off carburetor bowl.

Float height adjustment can be checked at this time. Float height is measured with carburetor body inverted. There should be 5/32-inch clearance between gasket surface of carburetor body and nearest edge of float, when measured at a point 180° from inlet valve. NOTE: Float is parallel to gasket surface of body when adjustment is correct. Adjust by bending tang which contacts inlet valve needle. After float height is properly set, adjust float drop to 3/16-inch by bending the vertical tang on float.

Do not remove main nozzle unless absolutely necessary for cleaning. If removed, the original main nozzle must be renewed, using the service part. Tighten new nozzle to a torque of 30-40 inch-pounds. Install throttle valve (10) with part number or stamped "W" trademark on idle needle side of carburetor bore and visible with throttle closed. Back out the idle speed stop screw and center the valve on throttle shaft by completely closing throttle as screws are tightened. Tighten float valve seat to a torque of 40-50 inch-pounds and bowl retaining nut to a torque of 50-60 inch-pounds, first making sure that main adjustment needle valve is not bottomed. Walbro repair parts are as follows:

- | | |
|-----------------------------|---------|
| Repair kit | 300-537 |
| Gasket kit | 92-501 |
| Inlet needle and seat | 200-502 |
| Main nozzle | 86-46 |

SPEED CONTROL LINKAGE. The speed control lever (10—Fig. Mc2) moves the magneto armature plate (9) to advance or retard the ignition timing. A synchronizer pin (9) contacts throttle valve lever (14—Fig. Mc1) to control the throttle valve.

To adjust the synchronization, refer to Fig. Mc3. Loosen nut (N) on top of throttle valve shaft. Move speed control lever until synchronizing pin (9) is in approximate position shown, move throttle valve lever (14) until it contacts synchronizer pin at

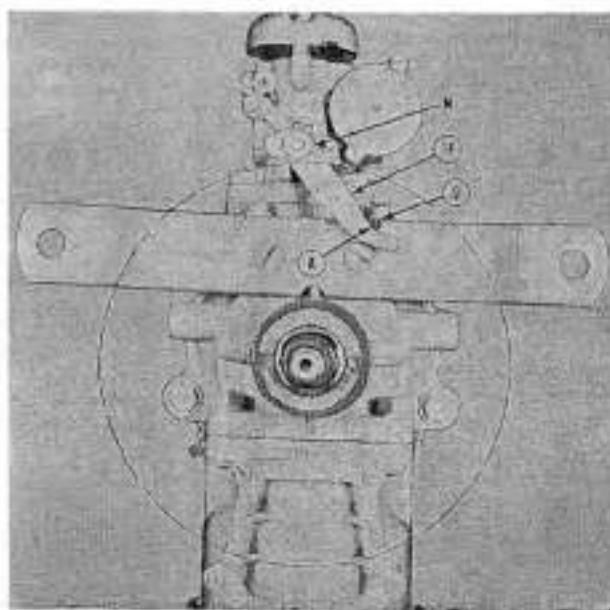

Fig. Mc3—To synchronize the linkage, rotate magneto stator plate until pin (9) is located at outer end of lever (14). Loosen nut (N) and move lever on throttle shaft until lever contacts pin (9) with throttle closed. Throttle should just start to open when pin reaches point (A) on lever.

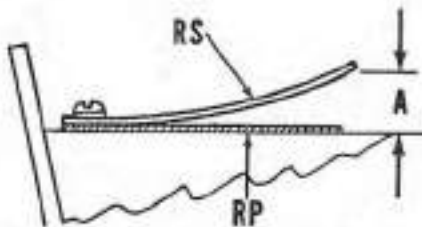

Fig. Mc4 — Cross sectional view of reed-type inlet valve. Reed petal (RP) should make full contact with plate. Bend reed stop (RS) until distance (A) measures 5/16 inch.

angle (A), then tighten nut (N). When adjustment is correct, throttle valve will just begin to open as speed control lever (10—Fig. Mc2) is moved further to the "Fast" position.

REED VALVE. The reed valve unit (2—Fig. Mc7) is located between the inlet manifold and crankcase. Reed petals should seat very lightly against the reed plate throughout their entire length with the least possible pressure. Check seating visually and/or by blowing and drawing air lightly through ports with mouth. Reed stop setting should be 1/8-inch when measured between end of stop and reed plate as shown at (A—Fig. Mc4). Renew the reed valve assembly if reed petals are broken, cracked, warped, rusted or bent. Seating surface of reed plate should be smooth and flat.

IGNITION

Breaker point gap should be 0.020 and can be adjusted after recoil starter and flywheel are removed.

For a quick test of magneto condition, remove the spark plug and hold spark plug wire about 1/4-inch away from cylinder head. Have someone spin the motor and note the condition of spark. Although spark may not be visible in bright daylight, a distinct snap will be noted as spark jumps the gap. If spark is weak or erratic, adjust the points as outlined above. Be sure to note point condition. If spark is weak although points are in good condition and properly adjusted, examine the condition of point, condenser and coil wiring, and the insulation on the magneto coils. Look for broken or worn insulation or broken wires. Also check for loose or corroded connections. Renew any parts which are damaged or in poor condition. Tighten the flywheel nut to a torque of 400 inch pounds when re-assembling.

COOLING SYSTEM

WATER PUMP. Motors are equipped with a rubber rotor type water pump which is mounted in the lower unit and driven by a cam on the drive shaft. Refer to Fig. Mc5. The rotor (3) oscillates in housing (4) because of the eccentric cam (2) on drive shaft (1). Rotor is prevented from turning, and water is prevented from recirculating

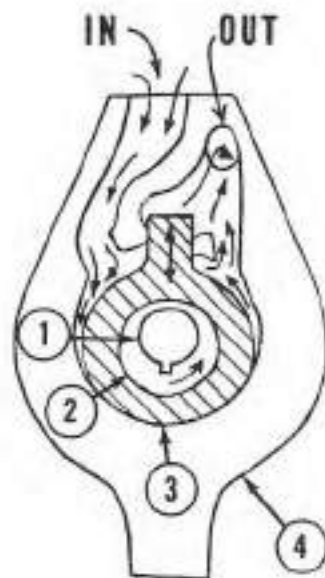

Fig. Mc5 — Schematic view of the rotor type water pump used on 3.6 horsepower models. Refer to text for details.

- 1. Drive shaft
- 2. Cam
- 3. Rotor
- 4. Housing

by the leg. As drive shaft turns, water is drawn into the pump (IN) and forced through the outlet (OUT) up into the power head. To disassemble the water pump, first remove the gearcase housing as outlined in LOWER UNIT section and proceed as follows: Remove the anti-cavitation plate (2—Fig. Mc6) and drive shaft (1). Rotor can now be withdrawn from gearcase housing. Cam (3) is pressed on a knurled section of drive shaft and is renewable separately. Rotor (4) and anti-cavitation plate (2) are both marked "TOP" for proper assembly.

POWER HEAD

R&R AND DISASSEMBLE. To overhaul the power head, clamp the motor on a stand or support and remove the starter assembly, fuel tank and lower skid. Remove flywheel, magneto stator plate, carburetor and inlet manifold. Refer to Fig. Mc7.

Remove the fuel tank supports (3 & 7), remove the screws retaining cylinder assembly (5) to exhaust housing and lift the power head off the lower unit.

Remove the cylinder head (8), then unbolt and carefully withdraw cylinder assembly (5) from crankcase and piston.

Engine components are now accessible for overhaul as outlined in the appropriate following paragraphs.

ASSEMBLY. When reassembling, make sure all joint and gasket surfaces are clean, free of nicks and burrs and hardened cement or carbon. Because of the two-cycle design, crankcase and inlet manifold must be completely sealed against both vacuum and pressure. Cylinder head must be sealed against water leakage and pressure. Gasket between power head and lower unit

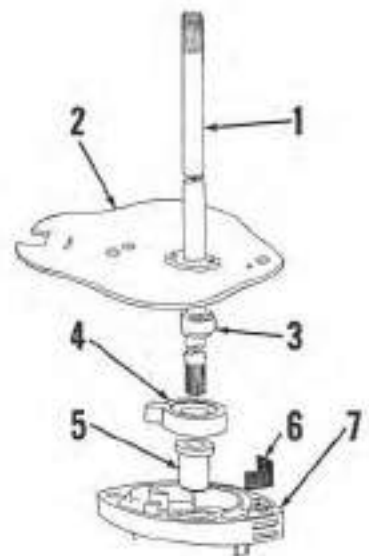

Fig. Mc6—Exploded view of water pump.

- 1. Drive shaft
- 2. Anti-Cavitation plate
- 3. Cam
- 4. Rotor
- 5. Bushing
- 6. Inlet screen
- 7. Gearcase housing

must be sealed against water and exhaust gas leakage. Flat gasket surfaces may be lightly lapped with No. 00 abrasive paper on a smooth surface to remove small nicks, raised threads or other irregularities. Smooth, but do not lower the surface. Use and approved gasket cement, such as Gas-tite, on all joint surfaces. Use sparingly and evenly, so that entire joint is sealed but excess cement will not flow into bearings or passages. Use Loctite or gasket cement on threads of all exposed screws.

When installing cylinder assembly over piston and on crankcase, use a new gasket, and make sure rings are properly positioned with relation to the ring groove pins. Lower edge of cylinder is chamfered to facilitate assembly and eliminate the necessity of a ring compressor. Use a new cylinder head gasket and tighten the cylinder head cap screws to a torque of 80 inch-pounds using the sequence shown in Fig. Mc8.

PISTON, PIN, RINGS AND CYLINDER.

Before detaching connecting rod from crankshaft, make certain rod and cap are properly marked for correct assembly.

Each piston is fitted with three rings which are interchangeable in grooves. Rings are pinned to prevent rotation in ring grooves as shown at (P—Fig. Mc9). NOTE: Middle ring is pinned at opposite side of piston from upper and lower rings.

Rings have a beveled inner edge which should be installed toward closed end of piston as shown at (B). Head end of piston is provided with a deflector (D) which directs the flow of the incoming fuel charge for proper scavenging of the cylinder. The

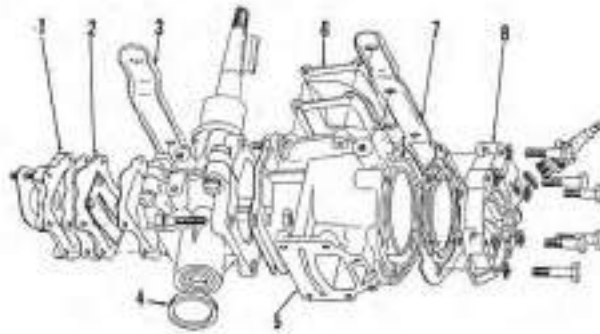

Fig. Mc7—Exploded view of power head. Reed valve assembly (2), cylinder (5) and head (8) are shown detached from crankcase. Refer to Fig. Mc10 for crankcase and crankshaft assembly.

1. Manifold
2. Reed valve
3. Front bracket
4. Seal
5. Cylinder
6. Transfer passage cover
7. Rear bracket
8. Cylinder head

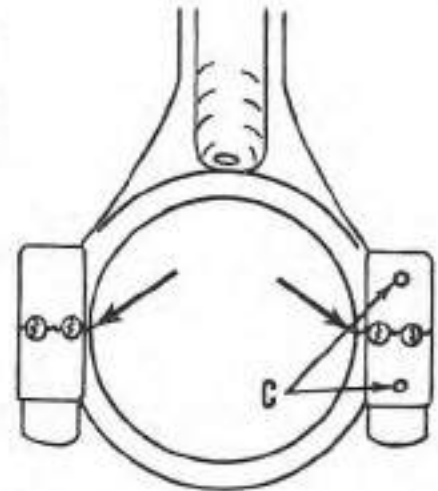

Fig. Mc11 — Uneven fractured parting line of rod and cap (shows by arrows), assures positive fit during assembly. Be sure correlation marks (C) are aligned.

long, sloping side of deflector should be installed down, toward exhaust port.

The full floating piston pin is a tight push fit in piston bosses and a slightly looser fit in rod. Fit is correct when piston will rock of its own weight on the rod, with no noticeable looseness. When installing piston on connecting rod, make sure that straight, vertical (intake) side of piston baffle is toward side of rod marked "TOP." All bearing and friction surfaces should be lubricated before assembly.

CONNECTING ROD, CRANKSHAFT AND CRANKCASE. Refer to Fig. Mc10. Before detaching connecting rod from crankshaft, make certain that rod and cap are properly marked for correct assembly.

Connecting rod is provided with 24 individual uncaged needle roller bearings at crankshaft end of rod. If surface of rod and cap which forms outer race for needle

rollers is rough, scored, worn or badly heat discolored, renew the connecting rod. Inspect crankpin, and if scored, out of round or worn, renew the crankshaft. The side of connecting rod marked "TOP" should face flywheel end of crankshaft. Parting faces of rod and cap are not machined, but are fractured at point of arrows, Fig. Mc11, to provide positive location. Rod cap should be shifted back and forth while tightening until fractured sections of joint are in perfect mesh. When tightened completely, the parting line of rod and cap is practically invisible.

To remove the crankshaft, remove the bolts connecting the two crankcase halves, and separate the halves. The crankshaft is supported in two renewable bronze bushings (12 & 20—Fig. Mc10). Inspect crankshaft and if crankpin and main journal surfaces are rough, scored, worn, out-of-round, or show evidence of overheating, renew the crankshaft. Renew main bushings if worn. Renew seal (9) and gaskets each time crankcase is disassembled. Crankcase halves are positively located during and after assembly by the ring-dowels (11). All friction surfaces should be lubricated during assembly.

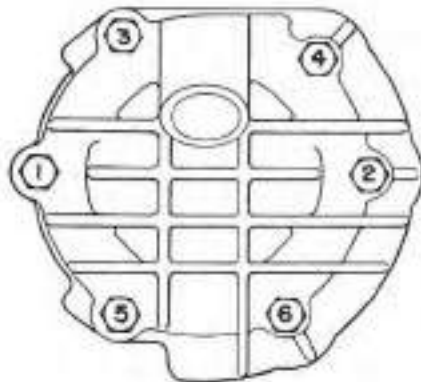

Fig. Mc8 — When installing cylinder head, tighten the retaining screws to a torque of 80 inch pounds in the sequence shown.

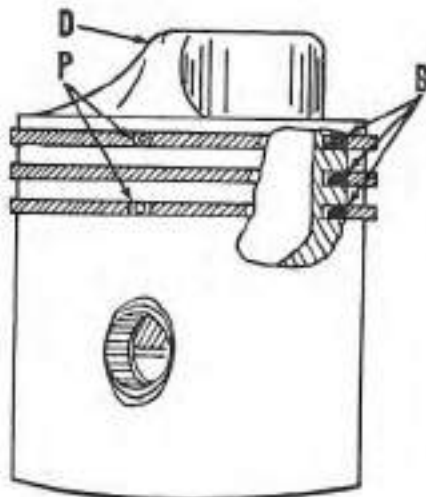

Fig. Mc9 — Cross sectional view of piston showing two of the three ring locating pins (P). The other pin is on opposite side of piston. Rings are installed with beveled inner edge (B) to the top. Deflector (D) directs the flow of incoming fuel charge for proper scavenging.

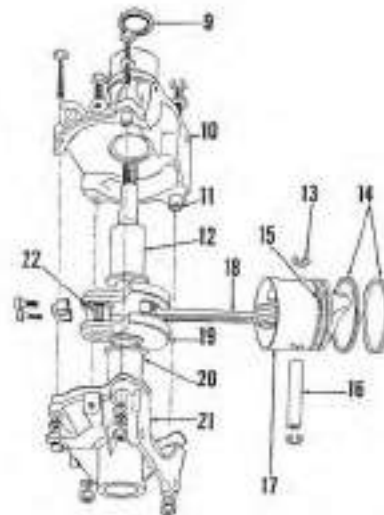

Fig. Mc10 — Exploded view of crankshaft, crankcase and associated parts. Refer also to Fig. Mc7.

- | | |
|------------------------|------------------------|
| 9. Seal | 16. Piston pin |
| 10. Crankcase half | 17. Piston |
| 11. Dowel | 18. Connecting rod |
| 12. Upper main bearing | 19. Crankshaft |
| 13. Retaining rings | 20. Lower main bearing |
| 14. Piston rings | 21. Crankcase half |
| 15. Locating pin | 22. Needle roller |

MANUAL STARTER

Fig. Mc12 shows an exploded view of the recoil starter assembly. To renew the starter pawls (11) or friction spring (9), remove the starter assembly, remove retaining ring from bottom of pivot bolt (7), then slip the spring and pawls from starter assembly.

To disassemble the starter, pull about two feet of rope from housing and tie a slip knot loosely in the rope. Pry the metal cap from starter handle, untie the retaining knot and remove the handle. Hold starter assembly with top toward you and with fingers pressing against pulley (5) to serve as a

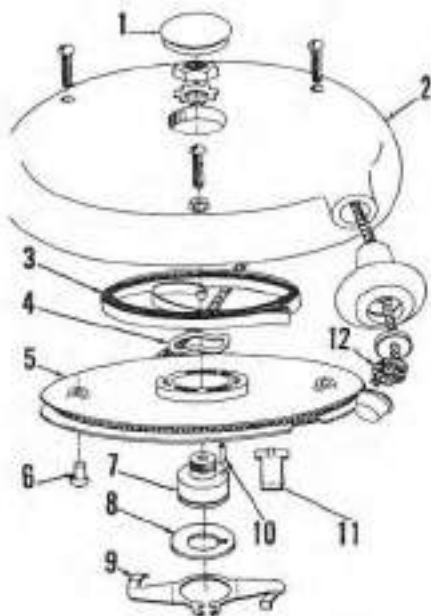

Fig. Mc12—Exploded view of recoil starter assembly.

- | | |
|-------------------|--------------------|
| 1. Cap | 7. Pivot bolt |
| 2. Housing | 8. Thrust washer |
| 3. Recoil spring | 9. Friction spring |
| 4. Spring washer | 10. Roll pin |
| 5. Starter pulley | 11. Pawl |
| 6. Nut | 12. Rope |

brake, then grasp free end of rope with other hand and pull to undo the previously tied slip knot. Slowly relieve tension on rope until free end enters starter housing (2), then allow the recoil spring to completely unwind.

After spring is unwound, remove the snap cap (1), and the nut, then disassemble the starter, making sure that spring (3) remains in housing (2). If spring is to be removed, clamp spring together with a pair of vise-grip pliers to prevent it unwinding. A replacement spring is coiled and secured with a band clip. Leave clip on spring until installed in housing.

When reassembling, make sure there is sufficient tension on recoil spring (3) to properly rewind all the rope.

LOWER UNIT

PROPELLER AND DRIVE PIN. Shear pin protection is carefully engineered for each unit. Protection depends on shear pin material as well as size. Although, in an emergency, the shear pin may be replaced by one of any available material, the correct shear pin should be installed as soon as possible to insure maximum performance and protection. The special recommended shear pin can be purchased under manufacturer's part number 462-3122, and a sup-

ply should be kept on hand by the motor user. Shear pin is $\frac{3}{16}$ x $\frac{1}{8}$ -inch brass pin. The motor uses a $7\frac{1}{2}$ -inch diameter, 8-inch pitch, two-blade propeller.

R&R AND OVERHAUL. Most service on the lower unit can be performed by detaching the gearcase housing from drive shaft and exhaust housing. When servicing lower unit, pay particular attention to water pump and water tubes with respect to air or water leaks. Leaky connections may interfere with proper cooling and performance of motor.

Use Figs. Mc13 and Mc14 as a guide when overhauling the lower unit. To renew the propeller shaft (14—Fig. Mc13), gears (17 or 12), bushings (13 or 18) or seal (10), first remove the propeller, remove drive pin (9), and unbolt and remove gearcase cap (19). Gear unit should be drained before disassembly. After gearcase cap has been removed, component parts can be withdrawn. Propeller shaft gear (17) is a press fit on shaft and should be removed with an arbor press. Bushings (13 and 18) are pre-sized and will not require reaming if carefully installed.

To remove the gearcase housing (7) from the exhaust and driveshaft housing, first drain the lower unit, remove gearcase cap (19), then remove the two retaining stud

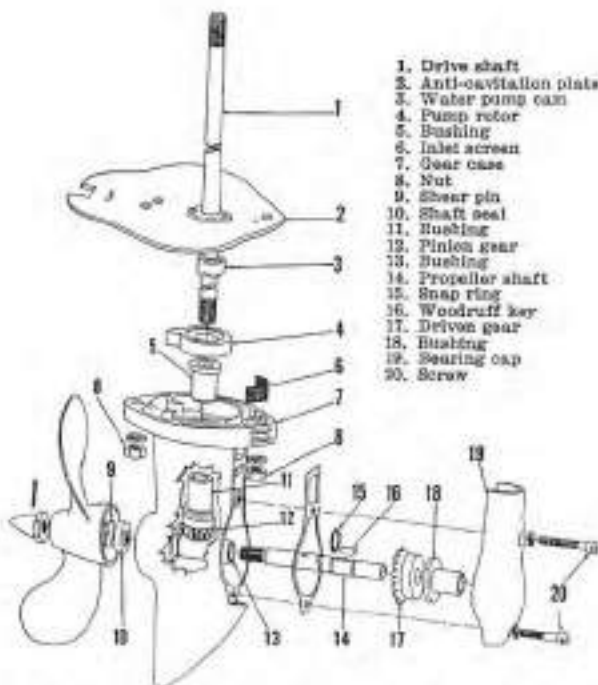

Fig. Mc13—Exploded view of direct drive gearcase, water pump, and associated parts. For 1963 gear shift models, refer to Fig. Mc15.

1. Drive shaft
2. Anti-cavitation plate
3. Water pump cam
4. Pump rotor
5. Bushing
6. Inlet screen
7. Gear case
8. Nut
9. Shear pin
10. Shaft seal
11. Bushing
12. Pinion gear
13. Bushing
14. Propeller shaft
15. Snap ring
16. Woodruff key
17. Driven gear
18. Bushing
19. Bearing cap
20. Screw

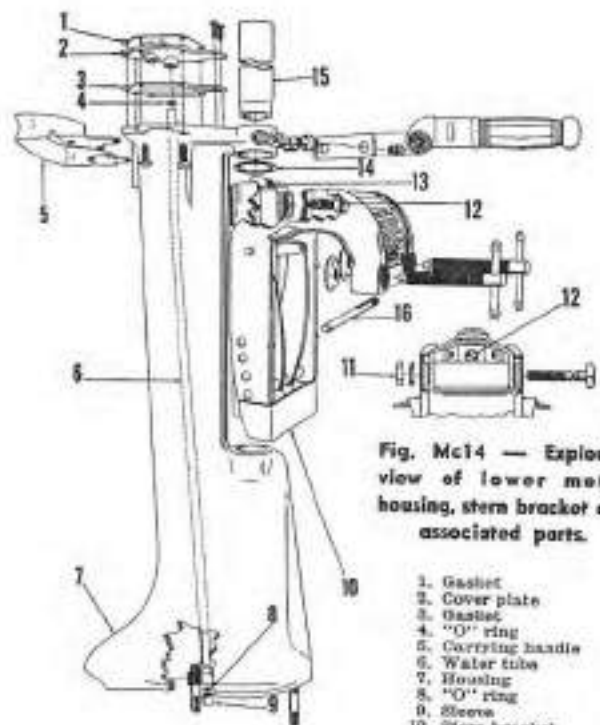

Fig. Mc14 — Exploded view of lower motor housing, stern bracket and associated parts.

1. Gasket
2. Cover plate
3. Gasket
4. "O" ring
5. Carrying handle
6. Water tube
7. Housing
8. "O" ring
9. Sleeve
10. Stern bracket
11. Adjusting nut
12. Adjusting screw
13. Friction pad
14. Thrust washer
15. Pivot tube
16. Tilt pin

nuts (8). Gearcase housing (7), driveshaft (1) and anti-cavitation plate (2) can then be withdrawn as a unit. Lift off the anti-cavitation plate (2), then withdraw driveshaft (1). Water pump cam (3) fits on a knurled portion of driveshaft and is renewable. Before removing the old cam, measure or mark the position of old cam; then install the new cam in the same relative position on the shaft.

Anti-cavitation plate (2) and water pump rotor (4) are marked "TOP" for correct assembly. The pre-stressed driveshaft lower bushing (5) can be renewed after removing and completely disassembling gearcase (7).

STEERING TENSION. The steering tension adjustment screw (12—Fig. Mcl4) adjusts the friction between pad (13) and pivot tube (15). Adjust the screw until motor is easy to steer but will maintain a set course.

GEAR SHIFT MODELS. Some 1963 models are equipped with a gear shift lower unit as shown in Fig. Mcl5. Use the exploded view as a guide when servicing the gear case and components on models so equipped.

Fig. Mcl5 — Exploded view of gear case and associated parts used on models with gear shift.

1. Drive pin
2. Propeller nut
3. Propeller nut
4. "O" ring
5. Drive shaft
6. Anti-cavitation plate
7. Grommet
8. Drive pin
9. Ingeifer
10. Pump flange
11. Seal
12. Seal
13. Bearing
14. Inlet screen
15. Gearcase housing
16. Needle bearing
17. Shift sleeve
18. Seal
19. Seal
20. Bearing
21. Thrust washer
22. Propeller shaft
23. Reverse gear
24. Thrust bearing
25. Drive piston
26. Clutch pin
27. Retaining ring
28. Clutch dog
29. Forward gear
30. Thrust washer
31. Needle bearing
32. Detent retainer
33. Plunger spring
34. Plunger
35. Cam detent
36. Nut
37. Selector fork
38. Shaft cam
39. Bearing cap

