

NISSAN OUTBOARD MOTOR



NS 9.9
NS 12
NS 15
NS 18



OWNER'S

OPERATING MANUAL

<https://www.boat-manuals.com/>

Copyright © 2007 Nissan Marine Co. Ltd. All rights reserved. No part of this manual may be reproduced or transmitted in any form or by any means without the express written permission of Nissan Marine Co., Ltd.

<https://www.boat-manuals.com/>



I PREFACE

Thank you very much for selecting our Nissan Marine Outboard Motor.

This operator's manual contains information on the operating procedures, preventive maintenance and inspection procedures of the Nissan Marine Outboard Motor Models NS9.9, NS12, NS15 and NS18. Please read this manual thoroughly before operating your Nissan outboard motor. You should become familiar with the correct operating procedures so as to assure many years of safe and pleasant boating.

© 1987 NISSAN MOTOR CO., LTD. TOKYO, JAPAN

<https://www.boat-manuals.com/>

CONTENTS

I PREFACE			
SPECIFICATIONS	1		
ACCESSORIES	2		
OPTIONAL PARTS	2		
II DAILY (PRESAILING) AND PERIODIC INSPECTION AND SERVICE	3		
1 PERIODIC INSPECTION AND SERVICE	3		
2 DAILY (PRESAILING) INSPECTION	3		
3. NORMAL MAINTENANCE SERVICE PARTS	3		
4 PERIODIC REPLACEMENT PARTS	4		
5 INSPECTION ITEMS AND INTERVALS	5		
6 DAILY INSPECTION	6		
(1) Inspection before starting engine	6		
(2) Inspection with engine running	7		
III HANDLING	8		
1. MOUNTING OUTBOARD MOTOR	8		
(1) Transom	8		
(2) Mounting position	9		
(3) Installation	9		
(4) Mounting angle	10		
2. PREPARATORY OPERATION AND MOTOR OPERATION	10		
(1) Preparatory operation	10		
① Fuel	10		
② Preparation	11		
③ Starting	11		
④ Cold engine starting procedure under different temperature conditions	16		
(2) Operation	17		
① Clutch lever	17		
② Throttle grip	17		
③ Engine rpm	18		
④ Steering operation	18		
⑤ Shallow water boating	18		
⑥ Stopping the engine	19		
⑦ Lifting the motor	20		
⑧ Removal and installation of the upper cover of the motor	20		
(3) Running-in operation	21		
① Procedure	21		
② Inspection after running-in	21		
(4) Handling after operation	22		
① When the motor is removed from the boat	22		
② After operation in salt water or muddy water	22		
③ Mooring	23		
④ When the motor is immersed in water	23		
IV DRIVE UNIT	25		
① Gear oil	25		
② Selection of propeller	25		
③ Replacement of anode (common preventing zinc electrode)	26		
④ Inspection of drive unit for damage and rust	28		
V SERVICING/BEFORE AND AFTER STORAGE	29		
1. PRESTORAGE INSPECTION AND SERVICE	29		
2. POST-STORAGE INSPECTION AND SERVICE	30		
TROUBLE-SHOOTING	31		
WIRING DIAGRAM	31		

SPECIFICATIONS

Model		N59.00	N512C	N515B	N518C
Overall length x overall width x overall height	mm (in)	569 x 345 x 1,052 (22.41 x 13.58 x 41.42)	569 x 345 x 1,052 (22.41 x 13.58 x 41.42)	569 x 345 x 1,052 (22.41 x 13.58 x 41.42)	569 x 345 x 1,052 (22.41 x 13.58 x 41.42)
Weight	kg (lb)	Approx. 35 (84)	Approx. 36 (84)	Approx. 38 (84)	Approx. 38 (84)
Engine type		2W155B1	2W155B3	2W155A1	2W160A1
Maximum output	PS (HP)	9.9 (13.76)	12.1 (16.6)	15 (14.8)	19 (17.7)
Fuel throttle speed range	rpm	4,500 - 5,300	4,500 - 5,400	4,750 - 5,500	4,750 - 5,500
Displacement	cm ³ (cu in)	247 (15.07)	247 (15.07)	242 (14.97)	294 (17.94)
No. of cylinders x bore x stroke	mm (in)	2 x 55 x 52 (2 x 2.17 x 2.05)	2 x 55 x 52 (2 x 2.17 x 2.05)	2 x 55 x 52 (2 x 2.17 x 2.05)	2 x 60 x 52 (2 x 2.36 x 2.05)
Cooling system		Water cooled, rubber impeller rotating type (with thermostat)			
Starting system		Recoil hand starting (with optional electric mechanism)			
Spark plug		(NGK) B7HS-10 *BR7HS-10 (CHAMPION) LB2C (Gap: 1 mm / 0.039 inch)			
Clutch type, gear shaft range		Dog clutch Forward, neutral, reverse			
Reduction rate		13.24			
Fuel and mixture ratio		Gasoline, oil (2-cycle oil) 50:1			
Gear oil	Recommended	SAE #80			
	cc (US pt., Imp. pt.)	Approx. 500 (5.7, 1.7)			
Fuel tank	2 lit. (8 gal., Imp. gal.)	24.45-3/8, 5-1/4; *25.16-5/8, 5-1/2; (Separate type)			

*: For Canada

ACCESSORIES

Service tools	Quantity
(1) Tool bag	1
(2) Pliers	1
(3) Socket wrench (10 x 13 mm) (0.39 x 0.51 in.)	1
(4) Socket wrench (71 mm) (2.8 in.)	1
(5) Socket wrench handle	1
(6) Screwdriver (standard)	1
Spare parts	
(1) Starter rope	1
(2) Spark plug	1
(3) Cutter pin	1
Others	
(1) Vinyl motor cover	1
(2) Flushing plug	1
(3) Owner's Operating Manual	1

OPTIONAL PARTS

(1) Remote control
(2) Lighting coil
(3) Rectifier kit
(4) Stop switch
(5) Electric starter
(6) Tachometer

II DAILY (PRESAILING) AND PERIODIC INSPECTION AND SERVICE

1. PERIODIC INSPECTION AND SERVICE

In order to maintain your Nissan Marine outboard motor in peak operating condition, and to assure safety during operation, Nissan Motors recommends that periodic inspection and service be performed on your outboard motor to check for abnormalities and worn or damaged parts. If any abnormalities are detected, they should be repaired and corrected immediately.

This periodic inspection and service is the purchaser's responsibility and is conducted at his expense.

It is strongly recommended that this inspection and service be conducted periodically, because it is indispensable for the safe and economical operation of your outboard motor.

It is also recommended that the Nissan Marine dealer conduct each periodic inspection and service on your motor.

2. DAILY (PRESAILING) INSPECTION

The daily or presailing inspection should be conducted by the user before starting the outboard motor. This will avoid problems and assure safe boating. In other words, the user should inspect his motor and ensure that it is free from defects and in good condition before sailing.

Nissan Motor Co., Ltd. strongly recommends that this daily inspection be conducted before sailing to ensure trouble-free motor operation and safe and pleasant boating. Remember that neglecting this inspection and minor troubles may lead to unexpected occurrence of serious problems. If any abnormalities are detected during this inspection, a Nissan Marine dealer should repair or service your outboard motor before you operate it.

When conducting this daily inspection, please follow the procedure described in the section "Daily Inspection Procedure."

3. NORMAL MAINTENANCE SERVICE PARTS

Some parts of the outboard motor must be replaced after a certain period of operation. These parts cannot be repaired and thus are called normal maintenance service parts.

Normal maintenance service Nissan Marine parts are as follows:

- ① Wires, cables and harnesses
- ② Screws, nuts and washers
- ③ Gaskets
- ④ Paint and plating
- ⑤ Hoses, oil seals, grommets, rubber mounts, impeller and rubber parts
- ⑥ Spark plugs, contact points, arms, brushes, fuses and other electrical items
- ⑦ Oil and grease
- ⑧ Shear pins, socket pins, drive pins and plugs
- ⑨ Thrust washers and propeller nuts
- ⑩ Propeller
- ⑪ Corrosion proof zinc
- ⑫ Starter rope
- ⑬ Resin parts

4. PERIODIC REPLACEMENT PARTS

Some maintenance parts of the outboard motor are designated as periodic replacement parts. Periodic replacement parts are those parts that do not show external indications of deterioration in quality or function even after the motor has been used for a long time. It is difficult to estimate the remaining life of these parts and to check whether they are functioning normally. These parts should be replaced after a certain period of operation so as to assure safe outboard motor operation. These parts should be replaced at the time of periodic inspection at the expense of the user.

When the motor has been operated for a long time, or storage conditions are poor, it is recommended that these parts be replaced early, even before the predetermined replacement period has expired. Periodic replacement parts of the Nissan Marine outboard motor and their replacement time are shown below.

Periodic replacement

Part	Replacement interval
1 Fuel hose	Every 2 years
2 Fuel tank	Every 3 years

5. INSPECTION ITEMS AND INTERVALS (Outboard motor)

No.	Inspection item	Frequency of inspection	Daily check	Periodic inspection		Remarks
				Every 20 hours or 2 months	Every 100 hours or 6 months	
1	Fuel intake for 1st operation*	○	○	○	○	
2	Fuel pump for operation			○	○	
3	Spark plug for contact	○	○ (When engine oil is added)	○	○	
4	Belt and nuts tightness, as necessary	○		○	○	
5	Universal joints and bearings of shaft		○	○	○	
6	Battery cable and terminals for condition*		○			
7	Battery electrolyte level*		○			
8	Springs, bushes, U-bolts for the axle*				○	
9	Stap wrench for operation*				○	
10	Coastline mirror for proper condition		○			
11	Drive shaft for damage and wear				○	
12	Propeller for damage and proper operation		○	○	○	
13	Fuel tank and hose for leakage and wear (including hoses)		○	○	○	Replace fuel hoses every 100 hours and fuel tank every three years.
14	Clutch cable for operation		○		○	
15	Carburetor for operation				○	
16	Throttle grip for operation		○		○	
17	Remote control lever for operation*		○		○	
18	Recoil starter for operation, as necessary		○		○	
19	Clutch lever for operation		○		○	
20	Idling stop solenoid				○	
21	Idling for condition	○	○		○	
22	Safety switch for operation		○			
23	Steering for operation		○		○	
24	Replacement of gear oil (check oil level)	○ (5 places)		○ (Back only)	○ (Replace)	
25	Adjustment of timing and rotating parts		○		○	
26	Amidships enclosure in condition					Check every year.
27	Trip and tilt for operation			○	○	
28	Stefly for a piston and spark plug (as necessary)		○			
29	Mixture ratio & quantity of fuel		○			

Note: The "daily check" includes inspection items for optional parts.

6. DAILY INSPECTION

Conduct a daily inspection in the sequence described below. If any abnormality or damage is noted, contact the nearest dealer for inspection and servicing.

(1) Inspection before starting engine

- ① Check outboard motor for proper installation.
- 1) Check that the clamp handle and stern bracket mounting bolts (optional parts) are properly tightened. Check transom mount for damage.

NOTE:

Be sure to tighten the clamp screw of the clamp handle by hand. Do not use a tool for tightening. Over-tightening of the clamp screw will damage the transom of the boat.

- ② Check propeller for damage and proper installation.
- 1) Ensure that the clutch lever is in the "N" (Neutral) position. Then check propeller for damage while turning slowly by hand.
- 2) Check propeller for proper installation, cotter pin for damage, and seals for oil leaks.

- 3) Check condition of anode (zinc electrode) attached to anti-cavitation plate. Retighten if necessary.

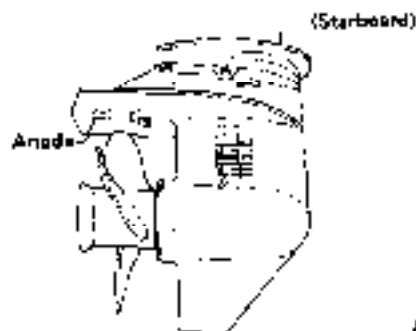

Fig. 1

NOTE:

Be sure to check the zinc electrode every week for corrosion. Replace if it is reduced to approximately 50% of original size. See p.28.

- ③ Check electrical connections for looseness or damage.
- Check high-tension cord and wire harness connectors for looseness or rust. Check harness surface for scratches or damage.
- ④ Check condition of battery cables and terminals (Optional).
- Check battery cable connections for looseness, cables for damage and terminals for rust.

- ⑤ Check the level of battery fluid (Optional).
- Check the level of battery fluid to see if it is even with the specified line. If the level very does not have a reference level, the fluid should be 5 to 10 mm (0.20 to 0.39 in) above the plates.

- ⑥ Check fuel strainer for contamination. Check fuel filter for contamination and clogging, and filter cup for collection of water.

NOTES:

- ▲ If the fuel filter is clogged with dirt, or there is water in the filter cup, remove the nut from the bottom of the filter cup by turning it counterclockwise with a wrench. Clean both the filter and cup.
- ▲ Also clean the inside of the fuel tank.

- ⑦ Check fuel tank and hoses for leaks or damage.
- Check carefully all surfaces of the fuel tank for damage. Check the fuel hose for damage, loose connections or fuel leaks.

NOTES:

- ▲ Replace the fuel hoses every two years.
- ▲ If damage or cracks are noted, replace the hoses immediately.
- ▲ Replace the fuel tank every three years.

⑧ Check choke valve for proper operation. Push and pull the choke rod to check for binding. Also check the rod for damage.

⑨ Check throttle grip for proper operation.

- 1) Turn the hand grip to adjust the throttle and check for excessive play. Check the linkage for proper operation.
- 2) Shift the clutch lever to "F" (Forward) and then to "R" (Reverse). Check for proper engagement of the recoil starter reel and the neutral lock ratchet.

⑩ Check steering for proper operation. Move the motor to the left and then to the right using the handle. Check for binding or jerky/rough movement. Also check that the handle is not loose.

After completing the above inspection, install the upper motor cover.

[2] Inspection with engine running

① Check recoil starter for proper operation.

- 1) Ensure that the clutch lever is in "N" position. Start engine and check the operation of the recoil starter.
- 2) Check recoil starter rope for damage or wear.
- 3) Quickly turn throttle grip 1/3 to 1/2 turn. Check that engine speed increases correspondingly.

NOTES:

- ▲ Do not race the engine under no-load conditions.
- ▲ After starting the engine, check whether cooling water flows normally from the drain port and the small water telltale port.

② Check condition of spark plug (only when motor fails to start).

Remove the upper motor cover and remove the spark plug. Check for carbon deposits or other contamination near the electrode.

NOTE:

Wipe contamination from around the electrode. If heavy carbon deposits are found, check the inside of the cylinder through the spark plug hole. If a heavy carbon deposit is noted inside, contact the nearest dealer for inspection and servicing.

③ Engine starting (with starter motor) (Optional)

Use the starting motor to start the engine and allow the engine to warm up for three to five minutes.

④ Check idling operation.

After warm-up, idle the engine and check for rough idling or other irregularities.

⑤ Check clutch lever for proper operation.

After making a safety check in front and behind the boat and making sure that the boat is moored safely with rope, shift clutch lever to "F" and then to "R". Increase engine speed slightly at each position to check whether shift lever operation is normal.

NOTES:

- ▲ The clutch lever should be shifted quickly.
- ▲ When checking clutch lever operation, decrease engine speed to idling as soon as thrust force is transmitted to the boat.
- ▲ If thrust force is transmitted to the boat before engine speed is increased or if no thrust force is transmitted when engine rpm's are increased, contact the nearest dealer for inspection and servicing.

⑥ Spare parts and accessories

Check spare parts, service tools and safety parts for damage. Ensure that none are missing

⑦ Fuel level in fuel tank

Ensure fuel tank contains enough fuel for your boating schedule

III HANDLING

1. MOUNTING OUTBOARD MOTOR

(1) Transom

Nissan Marine outboard motors are available in four sizes to fit different transom heights. Generally, long shaft types which permit the freeboard to be maintained at a higher level are popular for safety reasons.

The transom height is listed below.

Height of transom on boat	Height of outboard motor transom
	NS9.9, NS12, NS15, NS18
S	435 mm (17.13 in)
L	562 mm (22.13 in)
LL	634 mm (25.12 in)
XL	689 mm (27.13 in)

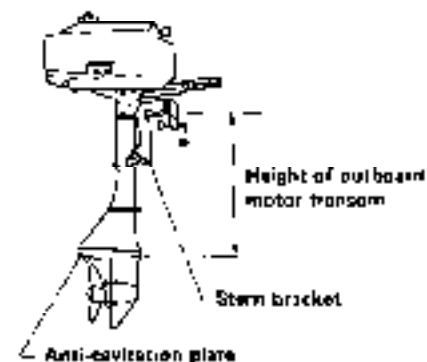

Fig. 2

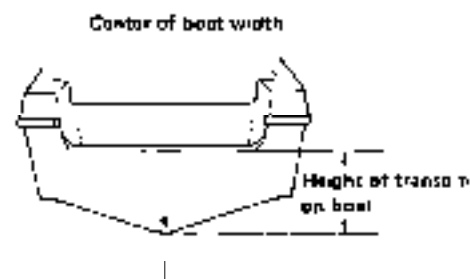

Fig. 3

(2) Mounting position

The mounting position of the outboard motor affects the performance of the boat. It should be installed on the center line.

The height of the anti-cavitation plate determines whether cavitation will be generated. The distance between the anti-cavitation plate and the bottom of the boat should be as small as possible within a range where no cavitation is generated.

Install your Nissan Marine outboard motor so that the distance between the bottom of the boat and the anti-cavitation plate is 30 to 50 mm (1.18 to 1.97 in).

If proper transom height is unobtainable due to hull design, adjust the height by inserting a wooden block between the upper portion of the transom and the stern bracket.

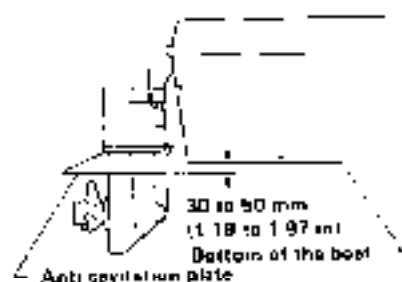

Fig. 4

(3) Installation

1. Install the outboard motor to the transom and securely tighten the two stern bracket clamp handles by hand.

NOTE

Do not use a tool to tighten the clamp handles, or the transom may be damaged. Be sure to tighten by hand.

To prevent the motor from falling, proceed as follows:

2. Drill four holes in the transom by aligning with the stern bracket bolt holes. Coat the holes (optional) with sealing agents to prevent water from entering and insert them in the bolt holes. Tighten the bolts with washers and nuts.

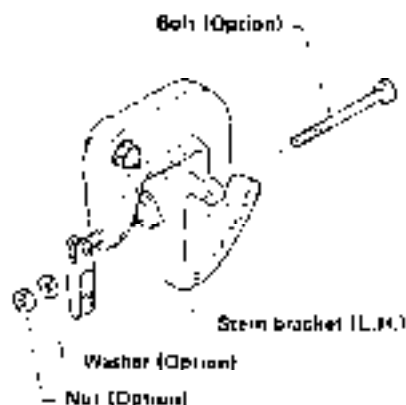

Fig. 5

(4) Mounting angle

If the boat is operated at maximum speed with the outboard motor installed, the motor will be at a right angle to the surface of the water. However, if the position of the boat is unsatisfactory due to design or load, use the locking lever located at the end of the thrust rod to make it parallel with the rod. Pull up on the thrust rod. Be careful that the socket does not fall off the rod. Change the position of the stern bracket tilt angle adjusting hole so that the motor is vertical in the water.

1. When the bow tends to rise while sailing. When the bow moves up and down so that the boat becomes unstable, change the stern bracket thrust bolt position to a mounting hole nearer the transom board.

2. When the bow tends to lower while sailing.

If the bow tends to lower while sailing so that waves easily splash over the bow, change the thrust bolt position to a mounting hole away from the transom board.

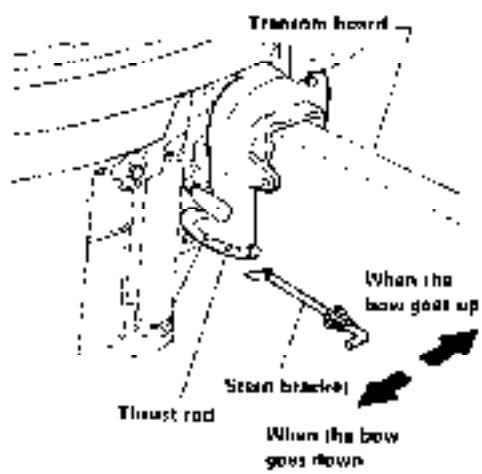

Fig. 6

2. PREPARATORY OPERATION AND MOTOR OPERATION

(1) Preparatory operation

(1) Fuel

1) Gasoline

Use automotive gasoline for the outboard motor. Octane rating of more than 86.

2) Lubricating oil (Two-cycle oil)

Use 2-cycle motor oil conforming to B.I.A. standard.

3) Mixing of fuel

a) The recommended fuel mixture ratio for gasoline and engine oil is 50:1. (Volume ratio)

b) Proper handling and operation during the initial run-in period, using the correct fuel mixture will extend engine life and maintain the original high performance and durability of the motor for a long time.

3. Stop the engine before filling with fuel.
4. When filling fuel, clean the fuel inlet port and surrounding area so foreign matter does not enter the fuel tank.
5. When supplying fuel from a portable container, make sure that the fuel in the container is clean. Do not use the fuel in the bottom of the container as it may contain impurities.
6. Wipe up any fuel that is spilled.
7. After fuelling, securely install the cap so that water and other foreign matter will not enter the tank.
8. Put enough fuel in the tank to complete your boating schedule with a safety margin.
9. Do not use a polyethylene container as a spare fuel tank, because polyethylene will eventually deteriorate and crack.

PRECAUTIONS:

1. During the first five hours of the run-in operation, use a fuel mixture ratio of 20:1.
2. During the next five hours of run-in, use a fuel mixture ratio of 50:1.

2) Preparation

- 1) After ensuring that the fuel tank contains enough fuel, attach the fuel hose to the fuel tank connector while pulling back its outer ring. Return the ring to its original position to lock. Then place the tank in its proper position and lay out the fuel hose correctly. Finally, attach the other end of the fuel hose to the engine.

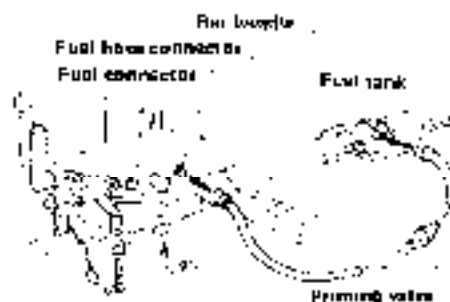

Fig. 7

- 2) Open the air vent located on top of the fuel tank cap by turning it counter clockwise.
- 3) Squeeze the priming valve located in the middle of the fuel hose to supply fuel to the carburetor. After squeezing about ten times, you will feel the valve harden. Stop priming when you feel this resistance.

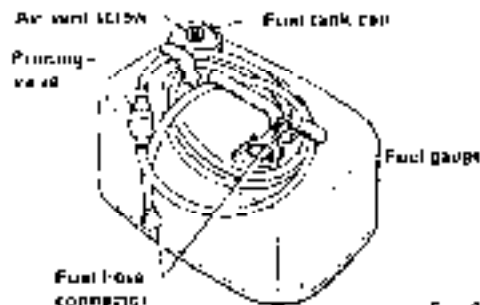

Fig. 8

3) Starting

1) STARTING THE ENGINE WITH RECOIL STARTER

- a) Insert the lock plate into the groove of the safety switch. Attach the hook end of the lock plate to the operator's belt.
- b) Pull out the choke rod knob located on the front of the lower motor cover.

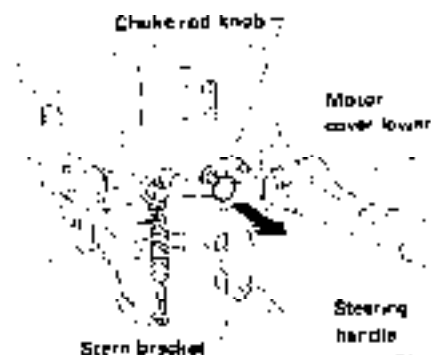

Fig. 9

NOTE:

If the engine is warm, it can be started without operating the choke.

- c) Shift the clutch lever located on the right of the motor cover to the neutral (N) position.

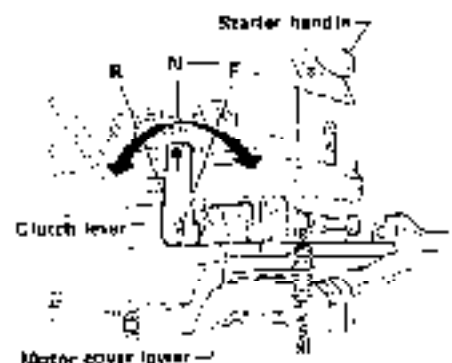

Fig. 10

NOTE:

If the clutch lever is in any position other than "N", the starter handle will lock and cannot be started.

- d) Turn the throttle grip until the mark on the grip is aligned with the "START" mark on the steering handle.

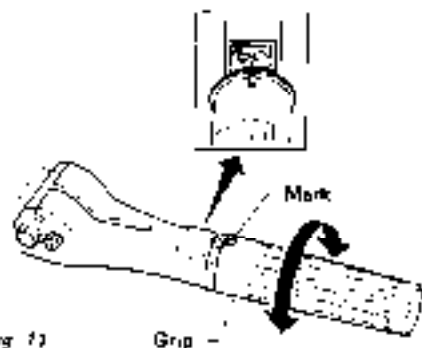
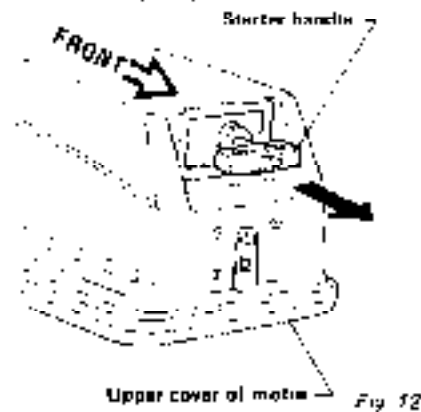

Fig 11 Grip

- e) At first, pull lightly on the recoil starter handle. The handle will meet resistance as the ratchet engages with the starter pulley. When this resistance is felt, apply more force to the handle. After starting the engine, do not let go of the handle, allow the starter rope to be returned evenly by the spring force of the starter pulley.



Upper cover of motor Fig 12

NOTE:

Don't pull the starter handle too fast. The engine will not start or the recoil starter may be damaged if the ratchet is not engaged with the starter pulley.

CAUTION:

When the clutch lever is in other than the "N" position, do not pull the handle with excessive force as the starter mechanism could be damaged.

- f) After the starter handle has been returned, push in the choke rod knob and turn the throttle grip slowly to lower engine speed.

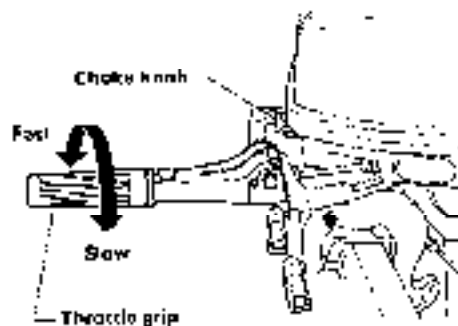

Fig 13

- g) **STARTING THE ENGINE WITH THE STARTER MOTOR (Optional):**
 a) Move the clutch lever located on the right of the lower motor cover to "Neutral".

NOTE:

The engine will not start unless the clutch lever is set to "Neutral" because the neutral switch activates to prevent the starter motor from starting.

- b) Turn the handle grip until the mark is aligned with the "START" position on the handle. Pull the choke knob out all the way to close the choke valve.

NOTE:

A warm engine can be easily started without using the choke. Start the engine with the choke knob pushed in.

- c) The starter switch is located between the fuel hose connector and choke rod, in front of the lower motor cover. (The starter switch is enclosed with a red cover.) Push the starter switch to start the engine. As soon as the starter motor starts the engine, release the switch.

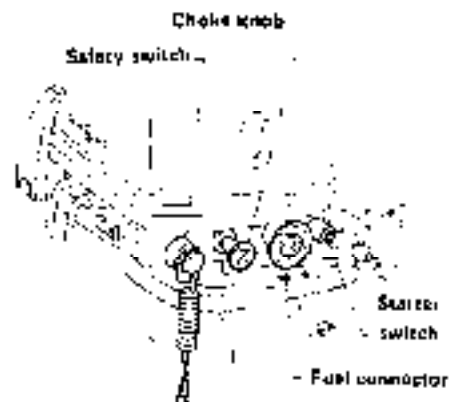

Fig. 14

CAUTION:

Do not operate the starter motor for more than five seconds at a time. If the engine does not start, wait approximately ten seconds before restarting.

d) After starting the engine, push the choke knob in. Gradually turn the throttle grip outward until the engine reaches its idling speed. Next, ensure that cooling water is discharging from the water tell-tale port located on the lower side of the lower motor cover, at the upper rear section of the drive shaft housing.

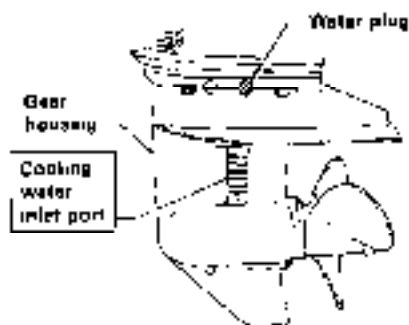

Fig. 15

CAUTION:

If no cooling water is being discharged, immediately stop the engine. Check the water inlet and remove dirt or foreign matter, if any.

If the inlet is not clogged, the problem is in other areas; contact your Nissan Marine dealer for checkup.

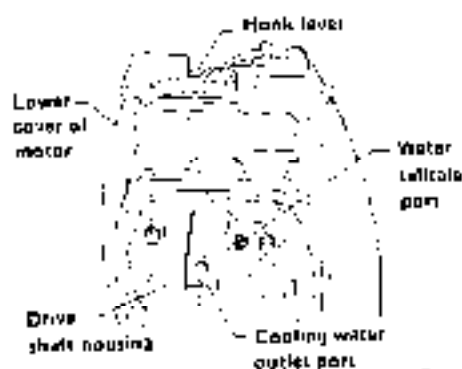

Fig. 16

e) When the engine is operating normally, warm it up for approximately three to five minutes until engine operation is stabilized.

The warm-up operation is important to keep the engine in top condition and to obtain maximum performance over a long period of time.

Type P (Option)

a) After ensuring the remote control box control lever is in "N" (neutral) position, slightly raise the free accelerator lever (to open the throttle valve slightly).

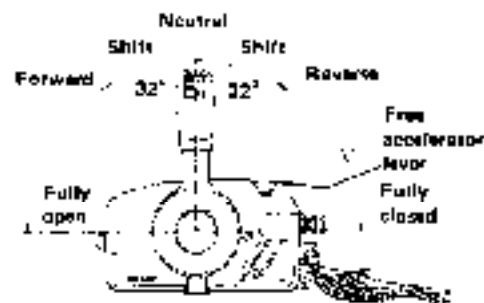

Fig. 17

NOTE:

Engine rpm can be controlled by the free accelerator lever only when the control lever is in the "N" position.

b) Next, insert the lock plate into the groove of the safety switch located on the front side of the remote control box, and attach the other end to the operator's belt or other suitable part of his clothing.

NOTES:

- ▲ The safety switch is provided for assuring security of the operator. If the operator leaves his normal operating position while sailing, the lock plate will pull off and the engine will stop. Therefore, it is important always to connect the hook on the other end of the lock plate to the operator.
- ▲ If the lock plate is not inserted into the safety switch, the engine will not start though the starter motor can be operated.
- ▲ The engine will stop if the lock plate is pulled off the safety switch.
- ▲ The engine will stop if the safety switch is pushed in with the lock plate inserted into the safety switch.

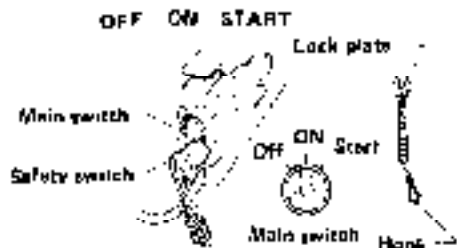

Fig. 18

c) The main switch is located on the front side of the remote control box. The "OFF" position is for inserting and removing the switch key and for stopping the engine. To start the engine, insert the key. Turn it from "OFF" to the "ON" position and press the key. This will activate the choke solenoid and fully close the choke. Then, while pressing the key, turn it to the "START" position. The starter motor will rotate and start the engine. Release the key as soon as the engine starts. The key will automatically return to the "ON" position.

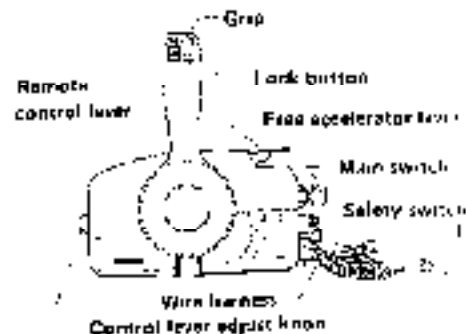

Fig. 19

NOTES:

- ▲ To restart the engine while it is warm, turn the key directly to the "START" position without pressing the key at the "ON" position.
- ▲ Do not rotate the starter motor more than five seconds at a time to start the engine. Wait about 10 seconds before trying again.
- ◻ After the engine has been started, gradually lower the free-reel lever (ever located in the remote control box) until engine rpm is lowered to idling. Next, check that cooling water is being discharged from the small outlet located on the right rear side of the engine.

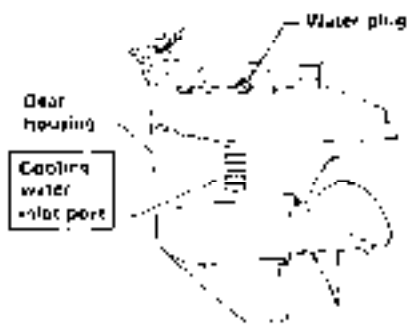

Fig. 20

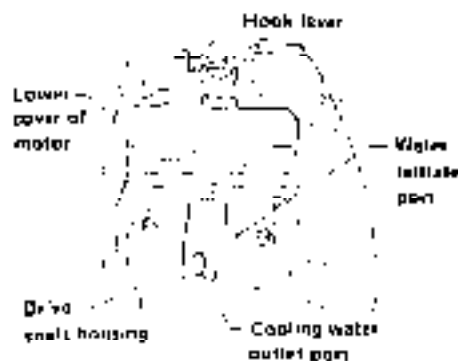

Fig. 21

locked. The pull the control lever down further toward "F", the throttle will open and the boat will begin to move.

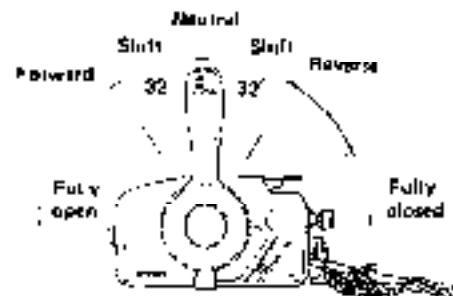

Fig. 22

NOTE:

If there is no water flow, immediately stop the engine and check to see if the cooling water inlet is clogged. If so, unclog. If no clogging is detected, the engine may be faulty. Consult the nearest dealer for repair.

e) Continue engine warm-up for three to five minutes until stable idling speed is obtained. Note that proper warm-up will extend the service life of the engine.

- Release control lever.
- a) Shifting into "F" (forward) or "R" (Reverse) and throttle operation can be performed by using a single control lever. When moving the boat in the forward direction, simultaneously grasp both the neutral lock built into the control lever and the lever grip. Move the lever from its "N" then shift position toward the "F" mark on the control box by tilting it about 32 degrees in a

- b) To shift the motor into reverse, turn the control lever in the reverse direction from the neutral position while simultaneously holding the neutral lock (built into the control lever) and the lever grip. Turn the control lever about 32 degrees from the "N" (Neutral) position toward "R" mark on the control box until the lever is locked.

Then tilt the control lever down further toward "R"; the throttle will open and the boat will begin to move in reverse. When moving the boat in reverse, do not open the throttle suddenly. Operate the control lever carefully so that the boat will move slowly.

CAUTIONS:

- ▲ When shifting the remote control lever from "N" to "F" or to "R", move the lever swiftly. Be careful not to jerk the lever.
- ▲ When shifting the lever from "F" to "R", or from "R" to "F", be sure to stop the movement of the lever at "N" for a moment.
- ▲ The remote control lever is locked and inoperative if the free accelerator lever is not in the lowest position. Confirm the free accelerator lever position before sailing.
- ▲ When moving the boat in reverse, use a low speed and pay particular attention to safety around the boat. Sudden acceleration in the reverse position may lead to an accident and result in damage to the motor and boat.
- ▲ Do not operate the engine in the full-throttle position for extended periods except in emergencies. Cruising speed is considered to be 60 - 80% of maximum speed. Maximum fuel economy and engine performance is attained at this speed.
- ▲ While cruising, avoid jerky operation of the throttle and sudden changes in clutch lever position.

2) Free accelerator lever

The free accelerator lever is provided for controlling only engine rpm. Use this free accelerator lever for controlling engine speed when operating the throttle to start the engine, when adjusting the throttle opening in warm-up operation, or when checking and adjusting engine rpm.

The throttle opens wider as the free accelerator lever is moved upward, resulting in increased engine rpm. After using this lever, be sure to return it to the lowest position which corresponds to the specified idling rpm (900 to 950 rpm).

CAUTIONS:

- ▲ When the remote control lever is set in the "N" (Neutral) position, do not increase engine rpm under no-load conditions; otherwise, the engine and the driving mechanism may be adversely affected.
- ▲ When the free accelerator lever is not in the lowest "RUN" position, the remote control lever remains locked, disabling the shifting and throttling mechanisms. After using the free accelerator lever, be sure to return it to the "RUN" position.

④ Cold engine starting procedures under different temperature conditions

Engine starting depends on air temperature. The basic starting procedure has been explained in the preceding sections. Starting techniques that can be employed when difficulty is encountered in starting the engine under different temperature conditions are described below.

1) Air temperature 25°C (77°F) or higher (Summer)

Set the throttle grip to the low-speed position, pull out the choke rod knob, and try starting the engine once using the recoil starter.

Next, set the throttle grip to the "START" position, push in the choke rod knob, and pull the recoil starter until the engine starts.

2) Air temperature 15 to 25°C (59 to 77°F) (Spring, autumn)

Set the throttle grip to the "START" position, pull out the choke rod knob and try starting the engine once using the recoil starter.

Next, push in the choke rod knob and operate the recoil starter until the engine starts.

3) Air temperature 15°C (59°F) or lower (Winter)

Set the throttle grip to the "START" position, pull out the choke rod knob, and try starting the engine until initial ignition occurs.

Next, push in the choke rod knob and operate the recoil starter until the engine starts.

(2) Operation

① Clutch lever

The clutch lever is located on the right side of the engine on the lower motor cover.

To move the boat forward, shift the clutch lever from the "N" (Neutral) position to the "F" (Forward) position.

To move the boat in reverse, shift the clutch lever from the "N" (Neutral) to the "R" (Reverse) position.

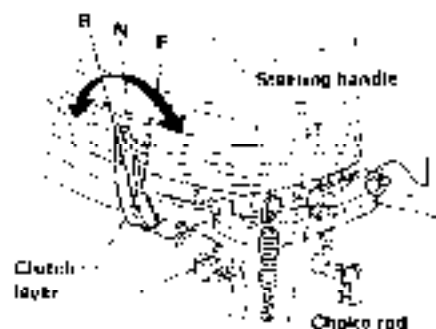

Fig. 27

CAUTIONS:

▲ When shifting the clutch lever, lower engine speed to idle.

▲ When shifting the clutch lever from "N" to "F", or to "R", move the lever quickly.

▲ Never attempt to shift the clutch lever while the engine is running at high speed; otherwise, the clutch mechanism may be damaged.

② Throttle grip

The throttle grip is an integral part of the steering handle. When the throttle grip is rotated inward with the clutch lever set in either "F" or "R" position, engine speed will increase and the boat will begin to move.

When the clutch lever is set to the "N" position, the engine speed can be controlled by rotating the throttle grip. However, the engine must not be operated at high speed under no-load conditions.

CAUTION:

▲ When the clutch lever is in "N" (neutral) do not race the engine, otherwise, the engine may be damaged.

▲ When operating the boat in reverse, to use a low speed. Pay particular attention to safety around the boat. Sudden acceleration in the reverse position may lead to a collision and result in damage to the motor and boat.

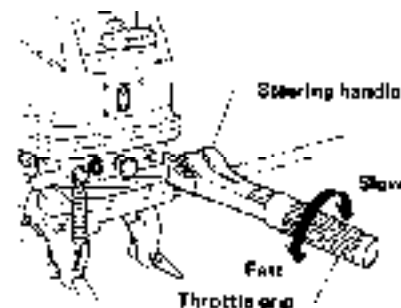

Fig. 28

▲ Do not operate the engine in the full-throttle position for extended periods except in emergencies. Cruising speed is considered to be 60 - 80% of maximum speed. Maximum fuel economy and engine performance is attained at this speed.

▲ While cruising, avoid jerky operation of the throttle and sudden changes in clutch lever position.

③ Engine rpm

Optimum engine idling speed after warm-up is listed below:

Clutch ON	Clutch OFF
500 ~ 700 rpm	600 ~ 900 rpm

The fully open throttle speed range is listed below. Be sure not to exceed those limits.

NS9.9, NS12	4,500 ~ 5,300 rpm
NS15, NS18	4,750 ~ 5,500 rpm

CAUTIONS:

▲ When operating the engine at full throttle, or at speeds exceeding the above-listed maximum speed, the propeller size will become mismatched. Choose a propeller of a suitable size that can match the desired engine speed.

▲ Continued operation of the outboard motor above the maximum speed range may cause seizure of the motor.

④ Steering operation

- 1) Steer the boat using the steering handle to which the throttle grip is attached. When the steering handle is moved to starboard, the bow of boat will turn in the port direction; when moved toward port, the bow will turn in the starboard direction.
- 2) If excessive resistance is felt in operating the steering handle, turn the adjusting bolt counterclockwise. This bolt is fitted with a coil spring and is located above the swivel bracket on the left side of the engine. Adjust the bolt with a wrench or a screwdriver so that the steering handle operates smoothly.

CAUTION:

Steering with outboard motor can cause large directional changes in a short period of time. Jerky steering at high speeds is very dangerous. Before making a turn, be sure to slow the boat.

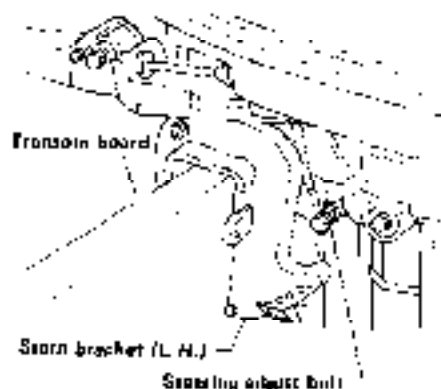

Fig. 25

⑤ Shallow water boating

- 1) Set the clutch lever in the neutral or forward position. Tilt the outboard motor upward to a position (approx. 30°) suitable for shallow water boating by moving the tilt handle located at the upper rear portion of the upper motor cover by hand. While holding the motor in that position, lower the tilt stopper grip located to the rear of the right-side stern bracket to lock the motor in the tilted position.

NOTES:

- ▲ While boating in shallow water, ensure that the cooling water suction port is below water. If the suction port is above water, the engine may overheat, or the water pump impeller may be damaged.
 - ▲ Always keep the propeller below water. If the propeller is too close the water surface, or above it, cavitation and engine overheating may occur.
 - ▲ Never attempt to sail at high speed in shallow water. Always run the engine at idling rpm or at low speed to ensure safe boating.
- 2) To return the outboard motor to the normal position from the shallow water position, tilt the motor upward a little by holding the tilt handle. While holding the motor at that position, raise the tilt stopper grip to release the tilt lock. Carefully return the outboard motor to the normal position.

NOTE:

When tilting the outboard motor up or down, do not use the grip handle to hold the motor as this may damage the throttle mechanism. Make it a rule not to hold the grip handle whenever tilting the motor up or down.

6 Stopping the engine

Type F

To stop the engine with safety switch
To stop the engine, turn the throttle grip to the low speed position and idle the engine. Then, set the clutch lever to the "N" (neutral) position.

After idling the engine for two or three minutes, remove the lock plate or push the stop switch button located on the motor cover.

In the latter case, keep the button pushed in until the engine comes to a stop.

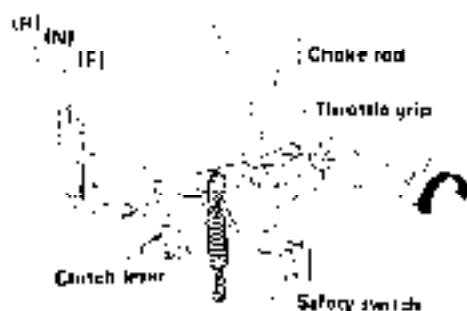

Fig. 26

Type P (Option)

To stop the engine, return the remote control lever to the "N" (Neutral) position and idle the engine for two to three minutes.

a) Stopping the engine with main switch

Turn the main switch key from the "ON" to "OFF" position.



Fig. 27

b) Stopping the engine with safety switch

To stop the engine using the safety switch located at the lower part of the remote control box, pull the lock plate off the safety switch or depress the safety switch until the engine stops. After stopping the engine with the safety switch, turn the main switch key to the "OFF" position.

CAUTION

The safety switch is provided for use in an emergency. Use the main switch to stop the engine under normal conditions.

⑦ Lifting the motor

1) Tilting up

The outboard motor can be tilted up in the same manner as in shallow water boating.

Hold the tilt handle located at the upper rear position of the upper motor cover and raise the motor to the uppermost position. Then, lower the tilt stopper clip located on the rear side of the right-hand stern bracket. The outboard motor will be locked in the tilted up position (upper position).

2) Tilting down

To return the outboard motor to the normal position from the tilted-up position, lift the motor a little by holding the tilt handle. While holding the motor at that position, raise the tilt stopper clip to release the tilt lock.

Lower the outboard motor carefully to the normal position while holding the tilt handle.

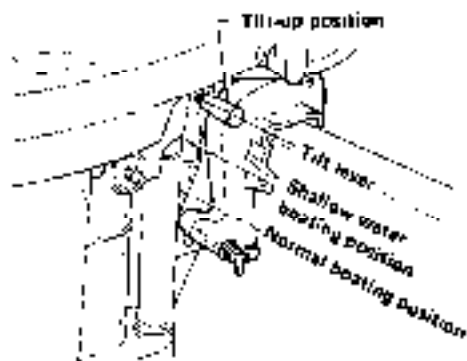

Fig. 28

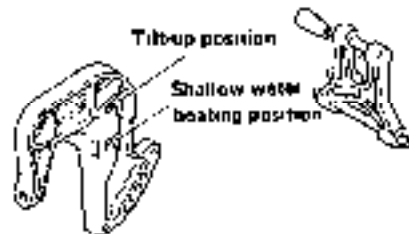

Fig. 25

CAUTION

When tilting the motor up or down, do not support the motor with the grip handle; otherwise, the throttle mechanism may be damaged.

When tilting up or down, be sure to use the tilt handle.

⑧ Removal and installation of the upper cover of the motor

1) Removal

The upper cover of the motor is secured to the lower cover with a hook lever on the back of the engine. Push the hook lever, down to unlock while holding the tilt handle of the upper cover, slightly lift the back of the upper cover to disengage it from the lower cover. Then, pull the entire upper cover toward the bow to disengage the front hook and remove the upper cover.

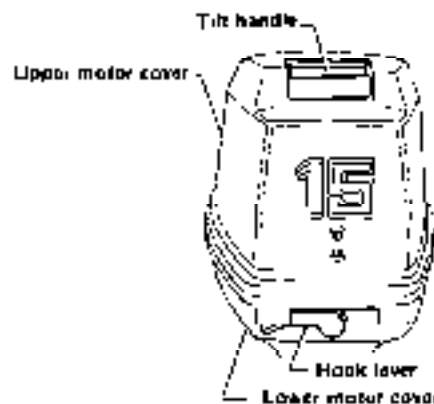
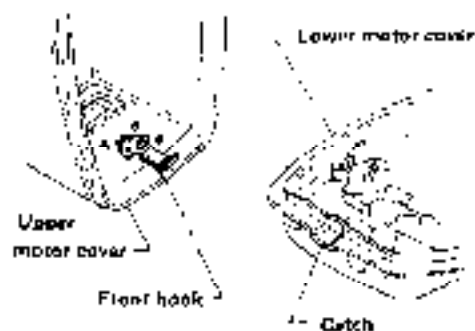

Fig. 30

2) Installation

While holding the upper cover with its back side raised, insert the front hook mounted on the inner front side of the cover into the catch of the lower cover. Fit the upper cover onto the lower cover by aligning the upper cover mounting hole with the recoil starter handle.

Next, engage the hook lever located on the back of the lower cover. This will lock the upper cover in position.



(3) Running-in operation

1) Procedure

1) It is important to note that the service life of an outboard motor depends largely on how it is operated during its initial period. Operation under heavily loaded conditions causes abnormal wear on sliding components before proper contact is achieved. This impairs engine performance for the rest of its life. The purpose of running-in the engine is to provide proper contact between sliding parts by avoiding undue loading during its initial operation period. This will assure high engine performance for an extended period of time.

2) The engine should be run for at least ten hours using the following procedure:

a) For the first 30 minutes, operate the motor at 1/4 throttle. After this period, gradually open the throttle to the 1/2 position, and continue motor operation for 2.5 hours.

During this three-hour running-in period, use fuel with a 20:1 gasoline-oil ratio.

b) During the subsequent two hours continue to run-in the engine by gradually opening the throttle from 1/2 to 3/4 position. Every 30 minutes during this period, fully open the throttle once for about 30 seconds (be sure not to

exceed the allowable maximum engine rpm).

During this two-hour period, use the 20:1 fuel mixture ratio.

c) After completing the first five hour period, change the fuel mixture to a 50:1 ratio, and conduct another five-hour running-in operation at 3/4 throttle. Every 30 minutes during this period, fully open the throttle once for about one minute (be sure not to exceed the allowable maximum engine rpm).

NOTES:

- Be sure to conduct the daily inspection before starting the running-in operation.
- Be sure to warm up the engine before starting the running-in operation.
- After starting the engine, do not operate at high-speed under no-load conditions.
- Avoid prolonged full-throttle operation during the running-in period.

(2) Inspection after running-in

The running-in operation is designed to achieve proper contact between rotating or sliding parts. This may result in some loosening of parts or production of metal shavings due to lapping action on the sliding surfaces. The outboard motor must be checked for these conditions after the running-in operation, and reconditioned as necessary to assure high performance during the service life. The inspection procedure is described below.

1) Check bolts and nuts for looseness. Retighten as necessary. Remove the motor upper cover. Check the mounting bolts and nuts of the following parts for looseness and retighten as necessary with a wrench.

Cylinder head, exhaust cover, inlet manifold, crankcase, carburetor, recoil starter, engine, drive shaft housing, gear case housing, propeller shaft housing.

2) Check fuel strainer for contamination.

Check the fuel strainer for contamination or clogging, and the strainer cup for water. Refer to the section "Daily inspection" for detailed procedures.

3) Check condition of spark plug.

Remove the spark plug and check for contamination and spark condition. See "Daily inspection".

22

4) Change gear oil

Remove the drain plug (located at the left bottom of the gear case) and the level check plug (located on the upper left part of the case) to drain thoroughly the gear oil. Using an oiler, fill with the specified quantity of new gear oil through the drain plug port.

Refer to "Gear oil" in section "Drive unit".

5) Check the idling condition.

After completing the above procedures, reinstall the motor cover, start the engine, and check the idling.

6) In case of problems

If any abnormality is noted during the above inspection, contact the nearest dealer for inspection and service.

(4) Handling after operation

(1) When the motor is removed from the boat

After removal, hold the motor in an upright position until the cooling water is thoroughly drained from the lower unit.

If it is necessary to lay the motor down, place it with the front side up. When storing the motor for long periods, be sure to use a stand and keep the motor in an upright position.

(2) After operation in salt water or muddy water

First, flush the cooling system with fresh water to prevent corrosion. Use the following procedure:

1) Flushing by operating engine:

Remove the propeller. While filling a tank or tub [at least 40 cm (15.75 in.) deep] with fresh water and while the water supply hose secured to the tank, immerse the lower unit of the motor in water. Run the engine at low speed for 10 to 15 minutes to remove salt and other contamination from the cooling system.

- 2) Flushing by circulating fresh water with engine stopped:

Remove the thermostat cap located on the cylinder head, and take off the thermostat. Reinstall the cap.

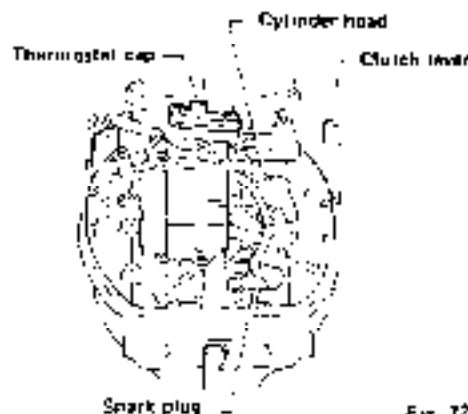

Fig. 32

Remove the water plug from the portion marked "WASH". Install the accessory flushing plug on the plug hole.

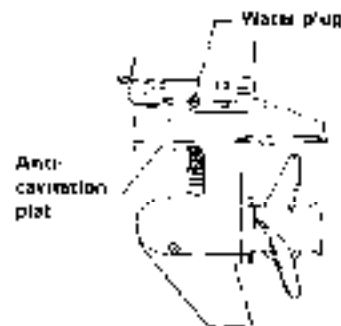

Fig. 33

Connect a rubber hose in a fresh water tap, and connect the other end of the hose to the flushing plug. Run fresh water for 10 to 15 minutes to flush the cooling system.

When flushing is completed, remove the flushing plug and reinstall the water plug. Reinstall the thermostat.

- 3) Wash the outside of the outboard motor with water, and wipe the entire surface with nonflammable solvent. Apply paint to scratches or pecked sections, if any. Apply rust preventer to the entire surface, and lubricate the sliding portions.

3) Mooring

If the boat is moored with the outboard motor in the water, metal parts may corrode, or the propeller and lower case may be damaged by striking bottom. To avoid these problems, tilt the motor up as far as possible.

- 1) Prevention of freezing (recoil starter)

In winter, when the air temperature drops below 0°C (32°F), pull the recoil starter handle several times and drain the cooling water from the engine. This will prevent freezing of cooling water and resultant damage to the engine.

- 2) Prevention of freezing. (Models with starter motor) (Optional)

To prevent freezing and resultant damage to the outboard motor, tilt the motor up, disconnect the high-tension cord from the spark plug, and then operate the starter motor for several seconds to completely drain the water from the outboard motor.

- 4) When the motor is immersed in water

If the outboard motor is dropped into water, it must be disassembled and serviced quickly. Delayed servicing may lead to rust formation inside the engine. Operation of a rusted motor will result in a damaged or disabled engine. Contact the nearest Nissan Marine dealer immediately and ask them to disassemble and service the motor, after conducting the following temporary procedure:

- 1) Remove the motor from the water as quickly as possible, and wash thoroughly with fresh water.
- 2) Remove the spark plugs. Pull the recoil starter handle to drain water from the engine cylinders through the spark plug holes.
- 3) After draining water from the engine, pour a sufficient amount of engine oil into the spark plug holes and into the

carburetor, and pull the recoil starter so that the oil will spread to every portion of the engine.

- 4) After completing the above procedure, take the motor to a Nissan Marine dealer and have it serviced.

IV DRIVE UNIT

① Gear oil

- 1) Use SAE No. 90 (API classification GL-4) gear oil. The amount of drive unit lubricating oil, specified for each of these four models is as follows.
Approx. 300 cc (3.8 U.S. pt. 1.1 Imp. pt.)

2) Be sure to replace the gear oil after completing the initial 10 hours of running-in operation.
After this, check and replenish the gear oil every 50 hours of operation.

CAUTION.

- ▲ When replenishing or replacing gear oil, be sure to remove the high tension cord from the spark plugs in advance to eliminate the possibility of accidents.
- ▲ When replenishing gear oil, check the oil in the drive unit for contamination or deterioration (cloudiness). If the oil is cloudy, contact the nearest dealer for inspection and servicing.
- ▲ When replenishing or replacing oil, pour oil into the gear housing until it comes out of the oil level check plug hole.

- 2) To replenish gear oil, remove the oil drain plug from the bottom of the gear case. Connect the nozzle of the oiler to the plug hole. Next, remove the level check plug from the upper part of the gear case. Pour new gear oil into the gear case. Stop when oil flows out of the oil level check hole. Insert the level check plug into the level check plug hole and tighten. Remove the nozzle of the oiler. At the same time install the drain plug. Ensure that the upper and lower plugs are tightened securely.

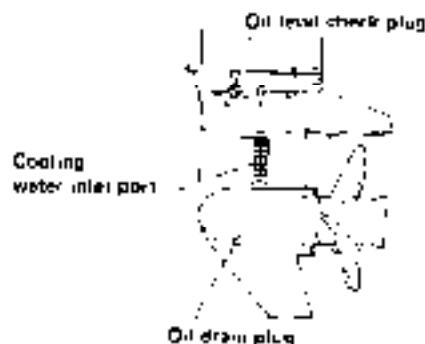

Fig. 34

NOTE:

Do not pour gear oil into the gear case from above. This will allow air to enter with the oil, preventing the specified amount of oil from being poured into the case.

② Selection of propeller

- 1) The propeller must be selected to suit the characteristics of the engine and boat, so that the original high performance of the engine and boat can be fully utilized.

Generally, propellers with a large diameter and small pitch are employed on large boats that need greater torque and are used for general-purpose cruising.

On the other hand, propellers having a small diameter and large pitch are employed on high speed boats. See page 22.

A propeller that greatly exceeds the maximum allowable engine rpm must not be selected, otherwise, the motor may be damaged.

The propeller should be selected by taking the following conditions into consideration: Engine output, size of boat, its shape, loading capacity, speed,

usage, etc. It is recommended that a Nissan Marine dealer be consulted when selecting a propeller for your motor.

2) The propeller size is indicated by "Diameter x pitch x No. of blades". The following propeller sizes are available for each mode of the Nissan Marine outboard motor.

List of propellers

(Diameter x Pitch x No. of blades)

Model	Size in (mm)	High speed Light-duty boat ←			→ Greater torque Heavy-duty boat	
		9.2 x 9.6 x 3 (234 x 250 x 3)	9.2 x 9.1 x 3 (234 x 231 x 3)	9.2 x 8.4 x 3 (234 x 214 x 3)	9.2 x 7.8 x 3 (234 x 199 x 3)	9.2 x 6.9 x 3 (234 x 174 x 3)
NS18			For transom S	For transom L, LL	For transom UL	
NS15				For transom S	For transom L, LL	For transom XL
NS12				For transom S	For transom L, LL	For transom XL
NS9.4				For transom S	For transom L, LL	For transom XL

- a) To prevent accidental starting of the engine while changing the propeller, ensure that the clutch lever is in the "N" position. Remove the engine cover and remove the spark plug wires.
- b) Remove the cotter pin from the propeller nut using a screwdriver or pliers.
- c) Loosen the propeller nut with a wrench while holding the propeller to prevent the shaft from rotating.

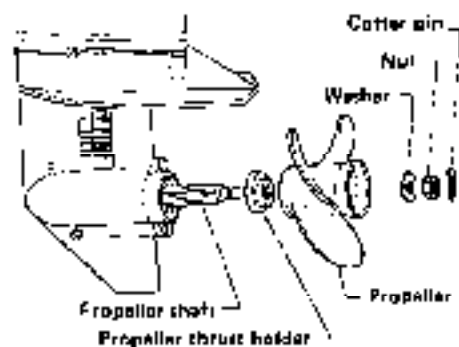

Fig. 35

- d) Next, remove the plain washer, propeller, and propeller holder, in that order from the propeller shaft.

- e) Check the propeller holder for damage.
 - f) When installing the propeller, wipe the propeller shaft and coat the entire shaft surface with a thin layer of grease.
 - g) Install the propeller holder, propeller and plain washer, in that order, to the propeller shaft. Ensure that the propeller and holder fit together properly.
 - h) After the propeller is in position, tighten the propeller nut to the shaft by hand. Then tighten securely with a wrench while holding the propeller to prevent the shaft from rotating. After tightening the nut, align the nut hole of the shaft with the groove on the nut. Insert the cotter pin and spread it open for locking.

NOTES:

- ▲ Be sure to replace the cotter pin with a new one whenever the propeller has been removed. Replace the shear pin if it is bent or damaged.
- ▲ After replacing the propeller, reinstall the spark plug wires, and the engine cover.

③ Replacement of anode (corrosion preventing zinc electrode)

An anode (zinc electrode) is provided under the drive unit anti-cavitation plate to prevent corrosion.

Replacement standards of anodes

If the anode (Zinc electrode) located on the anti-cavitation plate has eroded below replacement standards, immediately replace it. If left unheeded, rubber parts will deteriorate rapidly, resulting in a serious accident.

NOTES

- ▲ When replacing the anode, clean the mating surface on the anti-cavitation plate.
- ▲ Do not apply oil or paint to the anode or its mating surface.
- ▲ Be sure to retighten the anode mounting bolt when checking the anode for corrosion.

Anode by model	Dimensions	Standard dimensions					
		A	B	C	D	E	F
(NS9 9, 12, 15, 18)  Fig. 36	New mm (in)	7.8 (0.307)			24 (0.94)		
	Replacement std. mm (in)	7.0 (0.276)			18.5 (0.728)		

④ Inspection of drive unit for damage and rust

Carefully check the drive unit for colls or damage, peeling of paint, and rust. If necessary, repair or repaint.

V SERVICING/BEFORE AND AFTER STORAGE

Before placing the outboard motor into long-term storage, it should be serviced to keep it in good condition and free from rust and corrosion. This is called prestorage service.

When starting the motor after long-term storage, it is necessary to perform post-storage service to ensure safety and to prevent problems.

Contact the nearest Nissan Marine dealer for these maintenance services before and after long-term storage.

1. Prestorage inspection and service

(1) Flushing the cooling system

① Flushing

1) Remove the propeller, put the motor in a fresh water tank and run the engine for 10 to 15 minutes to flush the cooling system.

② Draining cooling water

1) Recoil starter type

a) Remove the motor from the tank and disconnect the spark plug wires. Operate the recoil starter to thoroughly drain the water from the inside of the motor.

2) Electric starter type (Optional)

Remove the outboard motor from the tank and disconnect high-tension leads

from spark plugs. Operate the starter motor to completely drain the water from the outboard motor.

2) Checking the propeller

a) Check the propeller for damage.

(2) Flushing of motor exterior and prevention of rust:

1) Wash the exterior of the motor with water. Then, wipe the entire surface with nonflammable solvent.

2) Check the exterior for damage, the mounting bolts and nuts for looseness, and the paint for peeling. Repair where necessary.

3) Apply rust-preventive oil or wax to the entire surface of the motor, and apply grease to the propeller shaft.

(3) Lubrication of engine

① Check carbon accumulation

Remove the spark plugs, and check the inside of each cylinder through the plug hole for carbon deposits. If an abnormal amount of carbon is noted, disassemble and remove carbon.

② Apply oil to cylinders

1) Recoil starter type

If no abnormality is noted, pour 2-cyrcle motor oil into the cylinder through the plug hole to lubricate the inside of the cylinder. Fully tighten the spark plugs

and operate the recoil starter so that the oil will coat the entire cylinder inner wall.

2) Electric starter type (Optional)

If no accumulated carbon is noted, apply enough 2-cyrcle motor oil to coat the entire cylinder through the mounting hole of the spark plug, and tighten the spark plug. Then, operate the starter motor to coat the entire area of the cylinder with oil.

(4) Replacement of gear oil

Drain the existing gear oil and pour the specified amount of new oil into the gear case.

(5) Cleaning of fuel system and rust prevention

1) Drain fuel from the carburetor, fuel pump, and fuel strainer. Remove these components from the engine, wash in nonflammable solvent, dry with compressed air and reinstall.

2) Spray corrosion preventing agent CRC or WD40 on the metal parts of the carburetor, fuel pump, fuel strainer and linkage.

3) Drain fuel from the fuel tank and wash the inside of the tank with nonflammable solvent.

(4) Wash the outer surface of the fuel tank with water, wipe clean, and dry. Apply rust-preventing oil to the exterior. Dry the inside of the tank thoroughly, and keep it capped.

(6) Electrical devices

Spray corrosion-preventing agent CRC or WD40 on the metal parts of the electrical devices and on the electrical wiring connectors.

(7) Zinc electrode

Check the anode (zinc electrode) for the amount of corrosion. Retighten the mounting screws.

(8) Application of grease

Apply grease to each of the following linkages and sliding parts.

1. Starter lock
2. Hook lever
3. Choke lever
4. Clutch lever
5. Throttle link
6. Handle grip
7. Bracket shaft bolt
8. Clamp screw
9. Tilt stopper
10. Recoil starter
11. Carburetor link

(9) Storage

Cover the outboard motor and store it in an upright position. Use a stand or rack in a well-ventilated, dry location.

2. Post-storage inspection and service

(1) Inspection of motor exterior

(1) Wipe clean the motor exterior and thoroughly remove the rust-preventing oil.

(2) Check the entire motor for damage or rust.

(2) Inspection of engine

(1) Remove the spark plugs and check the condition of each plug. If faulty, replace.

(2) Check the inside of the cylinder through the plug hole.

(3) Inspection of electrical connections for looseness or damage

Check each electrical connection for looseness and rust formation. Check each harness for damage and other electrical parts for defects.

(4) Inspection of fuel system

(1) If the fuel tank contains a mixture of fuel and oil, change the fuel to the specified mixture ratio. Connect the fuel tank hose to the engine and supply fuel to the fuel system.

(2) Check the fuel strainer, fuel pump and carburetor for fuel leakage. Check the hose joints for leaks, and the hoses for damage.

(5) Drive unit

(1) Check the gear oil level. Also check the drive unit for oil leaks.

(2) Check the zinc electrode for corrosion. If it has been reduced to 50% of its original size, replace with a new one.

(3) Wipe the grease from the propeller shaft and apply new grease, then install the propeller.

(6) Starting the engine and inspection

(1) Inspection of engine starting

1) Recoil starter type

Start the engine. Check the operation of the recoil starter and the starter rope for damage. Check the choke for operation and the operation of the starter locking mechanism.

2) Starter motor type (Optional)

Start the engine and check for operation of the engine, choke and neutral switch.

(2) Inspection of engine operation

(1) After warm-up, check engine idling, acceleration, hand grip operation and steering operation.

(3) Water/fuel leaks

(1) When starting the engine, check that cooling water is being discharged from the water outlet and from the tell-tale port. Check the engine cooling system for water leaks and the fuel system for fuel leaks.

TROUBLE-SHOOTING

Symptom \ Probable cause	Engine does not start	Engine starts but stops soon afterwards	Engine idling is not stable	Acceleration is poor	Engine speed is abnormally high	Engine speed is abnormally low	Boat speed does not increase	Engine overheats
Harbored air or is not of fuel	<input type="radio"/>	<input type="radio"/>						
Fuel lines are not properly connected	<input type="radio"/>	<input type="radio"/>	<input type="radio"/>	<input type="radio"/>		<input type="radio"/>	<input type="radio"/>	<input type="radio"/>
Air is sucked into fuel line	<input type="radio"/>	<input type="radio"/>	<input type="radio"/>	<input type="radio"/>		<input type="radio"/>	<input type="radio"/>	<input type="radio"/>
Fuel hose is twisted	<input type="radio"/>	<input type="radio"/>	<input type="radio"/>	<input type="radio"/>		<input type="radio"/>	<input type="radio"/>	<input type="radio"/>
Air vent is closed	<input type="radio"/>	<input type="radio"/>	<input type="radio"/>	<input type="radio"/>		<input type="radio"/>	<input type="radio"/>	<input type="radio"/>
Fuel filter, fuel pump or carburetor is clogged	<input type="radio"/>	<input type="radio"/>	<input type="radio"/>	<input type="radio"/>		<input type="radio"/>	<input type="radio"/>	<input type="radio"/>
Engine oil is of poor quality			<input type="radio"/>	<input type="radio"/>		<input type="radio"/>	<input type="radio"/>	<input type="radio"/>
Fuel is of poor quality	<input type="radio"/>		<input type="radio"/>	<input type="radio"/>		<input type="radio"/>	<input type="radio"/>	<input type="radio"/>
Mixture ratio of fuel oil is high			<input type="radio"/>	<input type="radio"/>		<input type="radio"/>	<input type="radio"/>	<input type="radio"/>
Mixture ratio of fuel oil is low						<input type="radio"/>	<input type="radio"/>	<input type="radio"/>
Excessive fuel is sucked in	<input type="radio"/>			<input type="radio"/>				
Carburetor is not properly adjusted	<input type="radio"/>	<input type="radio"/>	<input type="radio"/>	<input type="radio"/>		<input type="radio"/>	<input type="radio"/>	<input type="radio"/>
Restriction or pipe is broken	<input type="radio"/>	<input type="radio"/>	<input type="radio"/>	<input type="radio"/>			<input type="radio"/>	<input type="radio"/>
Spark plug of different specification is used		<input type="radio"/>	<input type="radio"/>	<input type="radio"/>		<input type="radio"/>	<input type="radio"/>	<input type="radio"/>
Spark plug is fouled	<input type="radio"/>	<input type="radio"/>	<input type="radio"/>	<input type="radio"/>		<input type="radio"/>	<input type="radio"/>	
Spark plug is faulty	<input type="radio"/>	<input type="radio"/>	<input type="radio"/>	<input type="radio"/>		<input type="radio"/>	<input type="radio"/>	
Inadequate or no cooling water is supplied						<input type="radio"/>	<input type="radio"/>	<input type="radio"/>
Thermostat does not operate properly			<input type="radio"/>					<input type="radio"/>
Overheating occurs				<input type="radio"/>	<input type="radio"/>		<input type="radio"/>	<input type="radio"/>

Symptom \ Probable cause	Engine does not start	Engine starts but stops soon afterward	Engine idling is not stable	Acceleration is poor	Engine speed is abnormally high	Engine speed is abnormally low	Boat speed does not increase	Engine overloads
Improper propeller is selected				○	○	○	○	○
Propeller is broken or damaged				○	○	○	○	○
Thrust rod is not properly positioned				○	○		○	
Charge is loaded in improper position				○	○	○	○	
Transmission shift is not proper				○	○	○	○	○
Stop switch is short-circuited	○					○	○	
Clutch link is not properly adjusted	○		○	○		○	○	
Ignition timing is not properly adjusted	○	○	○	○		○	○	○
Battery is discharged or fuse is blown*	○							

* Optional

NS9.9, NS12, NS15, NS18 WIRING DIAGRAM

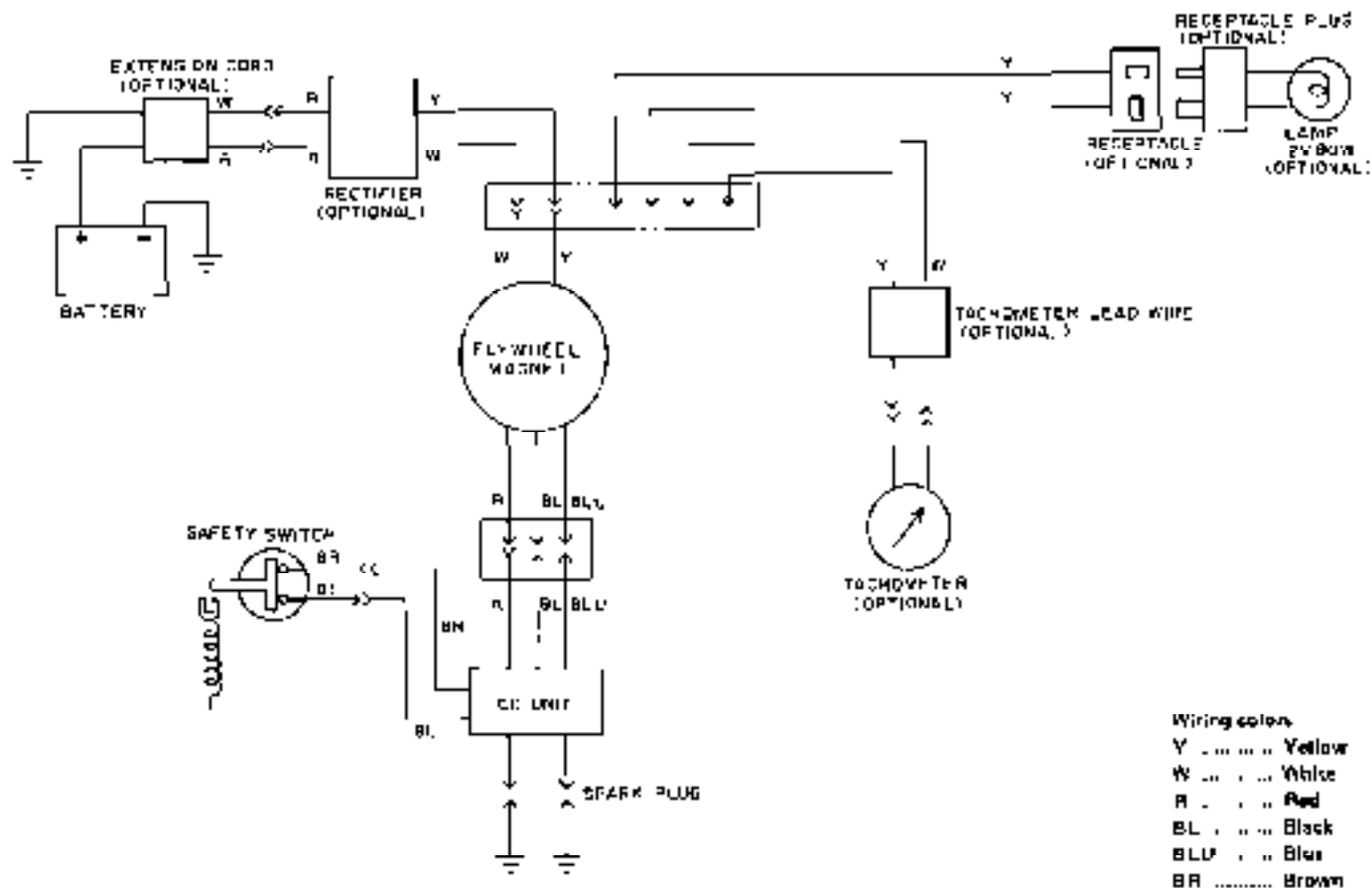

Fig. 37

NS9.9, NS12, NS15, NS18 WIRING DIAGRAM (EP-type)

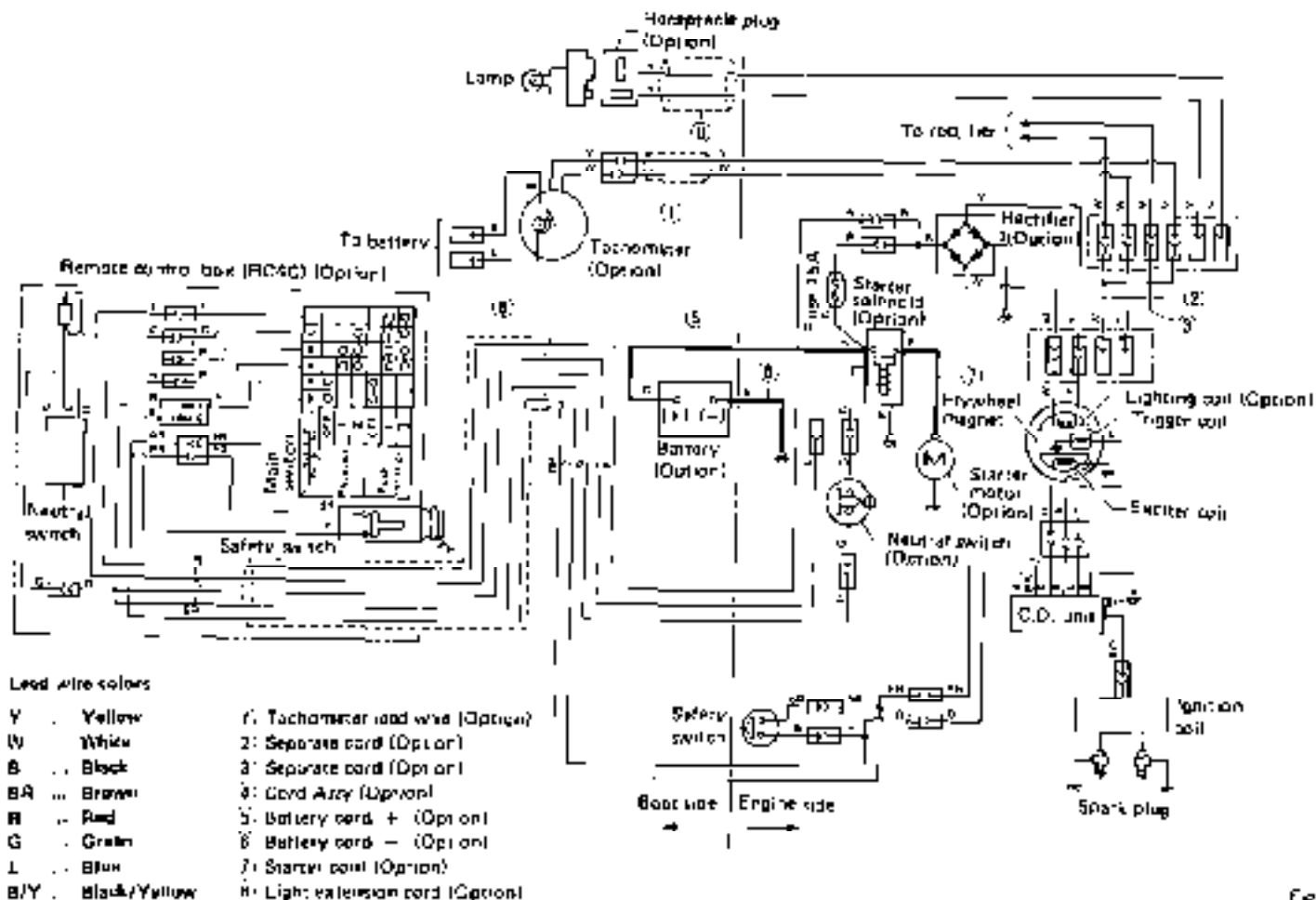

Fig. 20



NISSAN MOTOR CO., LTD.

Tokyo, Japan

Edition: March 1986
Printing: June 1992
Printed in Japan

Pub. No. M-241-A
M-2060500-T5