

# **YAMAHA**

**Marine**

## **Water Vehicles**

### ***WaveRunner***

### **GP760**

### **GP1200**

**SERVICE MANUAL** (E)  
**MANUEL D'ENTRETIEN** (F)  
**WARTUNGSHANDBUCH** (D)  
**MANUAL DE SERVICIO** (ES)

**460042**

## PREFACE

This manual has been prepared by the Yamaha Motor Company primarily for use by Yamaha dealers and their trained mechanics when performing maintenance procedures and repairs to Yamaha equipment. It has been written to suit the needs of persons who have a basic understanding of the mechanical and electrical concepts and procedures inherent in the work, for without such knowledge attempted repairs or service to the equipment could render it unsafe or unfit for use.

Because the Yamaha Motor Company Ltd. has a policy of continuously improving its products, models may differ in detail from the descriptions and illustrations given in this publication. Use only the latest edition of this manual. Authorized Yamaha dealers are notified periodically of modifications and significant changes in specifications and procedures, and these are incorporated in successive editions of this manual.

A1000107

**GP760, GP1200  
SERVICE MANUAL  
©1997 Yamaha Motor Co., Ltd.  
1st Edition, May 1997  
All rights reserved.**

**No part of this publication may be reproduced or transmitted in any form or by any means including photocopying and recording without the written permission of the copyright holder.**

**Such written permission must also be obtained before any part of this publication is stored in a retrieval system of any nature.**

**Printed in the Netherlands  
P/N GP7-28197-Z7-C1**

## HOW TO USE THIS MANUAL

### MANUAL FORMAT

All of the procedures in this manual are organized in a sequential, step-by-step format. The information has been compiled to provide the mechanic with an easy to read, handy reference that contains comprehensive explanations of all disassembly, repair, assembly, and inspection operations.

In this revised format, the condition of a faulty component will precede an arrow symbol and the course of action required will follow the symbol, e.g.,

- Bearings

Pitting/Damage → Replace.

To assist you to find your way about this manual, the Section Title and Major Heading is given at the head of every page.

An Index to contents is provided on the first page of each Section.

### MODEL INDICATION

Multiple models are shown in this manual. These indications are noted as follows.

Model name	WaveRunner GP760	WaveRunner GP1200
	GP760	GP1200
Indication	GP760	GP1200

### THE ILLUSTRATIONS

Some illustrations in this manual may differ from the model you have. This is because a procedure described may relate to several models, though only one may be illustrated. (The name of model described will be mentioned in the description).

### REFERENCES

These have been kept to a minimum; however, when you are referred to another section of the manual, you are told the page number to go to.

---

**WARNINGS, CAUTIONS AND NOTES**

Attention is drawn to the various Warnings, Cautions and Notes which distinguish important information in this manual in the following ways.

 The Safety Alert Symbol means **ATTENTION! BECOME ALERT! YOUR SAFETY IS INVOLVED!**

** WARNING**

---

Failure to follow **WARNING** instructions **could result in severe injury or death** to the machine operator, a bystander, or a person inspecting or repairing the water vehicle.

---

** CAUTION**

---

A **CAUTION** indicates special precautions that must be taken to avoid damage to the water vehicle.

---

**NOTE:**

---

A **NOTE** provides key information to make procedures easier or clearer.

---

**IMPORTANT:**

---

This part has been subjected to change of specification during production.

---















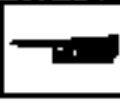







## HOW TO READ DESCRIPTIONS

1. A disassembly installation job mainly consists of the exploded diagram ①.
2. The numerical figures represented by the number ② indicates the order of the job steps.
3. The symbols represented by the number ③ indicates the contents and notes of the job. For the meanings of the symbols, refer to the next page(s).
4. The REMOVAL AND INSTALLATION CHART ④ is attached to the exploded diagram and explains the job steps, part names, notes for the jobs, etc.
5. The SERVICE POINTS, other than the exploded diagram, explains in detail the items difficult to explain in the exploded diagram or REMOVAL AND INSTALLATION CHART, the Service points requiring the detailed description ⑤, etc.

**JET PUMP NOZZLE, DUCT AND INTAKE**  
NOZZLE, DUCT AND INTAKE  
EXPLODED DRAWING

**④ JET PUMP NOZZLE, DUCT AND INTAKE**  
REMOVAL AND INSTALLATION CHART

NO.	FUNCTION/STEP	QTY.	REMARKS
	NOZZLE, DUCT AND INTAKE		
	DISASSEMBLY		
	JET PUMP UNIT		
1	Jet pump housing	2	
2	Cone	2	
3	Hose (with connector)	1	
4	Hose	1	
5	Intake duct	1	
6	Pin	2	
7	Washer	1	
8	Pin	2	
9	Washer and spacer	1	
10	Pin	2	
11	Washer	1	
12	Jet pump housing	1	
13	Spacer	1	
14	Oil seal	2	
15	O-ring	1	
16	Lock screw (washer)	2	
17	Lock screw	1	
	NOZZLE DEFLECTOR (with SERVICE POINT)		
18	Jet pump housing	2	2 in 1 job each
19	Pin	2	
20	Pin	1	left
21	Pin	2	left
22	Pin	1	left
23	Pin	1	left
24	Pin	2	left
25	Pin	1	left
26	Pin	1	left
27	Pin	1	left
28	Pin	1	left
29	Pin	1	left
30	Pin	1	left
31	Pin	1	left
32	Pin	1	left
33	Pin	1	left
34	Pin	1	left
35	Pin	1	left
36	Pin	1	left
37	Pin	1	left
38	Pin	1	left
39	Pin	1	left
40	Pin	1	left
41	Pin	1	left
42	Pin	1	left
43	Pin	1	left
44	Pin	1	left
45	Pin	1	left
46	Pin	1	left
47	Pin	1	left
48	Pin	1	left
49	Pin	1	left
50	Pin	1	left
51	Pin	1	left
52	Pin	1	left
53	Pin	1	left
54	Pin	1	left
55	Pin	1	left
56	Pin	1	left
57	Pin	1	left
58	Pin	1	left
59	Pin	1	left
60	Pin	1	left
61	Pin	1	left
62	Pin	1	left
63	Pin	1	left
64	Pin	1	left
65	Pin	1	left
66	Pin	1	left
67	Pin	1	left
68	Pin	1	left
69	Pin	1	left
70	Pin	1	left
71	Pin	1	left
72	Pin	1	left
73	Pin	1	left
74	Pin	1	left
75	Pin	1	left
76	Pin	1	left
77	Pin	1	left
78	Pin	1	left
79	Pin	1	left
80	Pin	1	left
81	Pin	1	left
82	Pin	1	left
83	Pin	1	left
84	Pin	1	left
85	Pin	1	left
86	Pin	1	left
87	Pin	1	left
88	Pin	1	left
89	Pin	1	left
90	Pin	1	left
91	Pin	1	left
92	Pin	1	left
93	Pin	1	left
94	Pin	1	left
95	Pin	1	left
96	Pin	1	left
97	Pin	1	left
98	Pin	1	left
99	Pin	1	left
100	Pin	1	left

① GEN INFO 	② SPEC 
③ INSP ADJ 	④ FUEL 
⑤ POWR 	⑥ JET PUMP 
⑦ ELEC 	⑧ HULL HOOD 
⑨ TRBL ANLS 	⑩ 
⑪ 	⑫ 
⑬ 	⑭ 
⑮ 	⑯ 
⑰ 	⑱ 
⑲ 	⑳ 
㉑ 	㉒ 
㉓ 	㉔ 

## SYMBOLS

Symbols ① to ⑨ are designed as thumb-tabs to indicate the content of a chapter:

- ① General Information
- ② Specifications
- ③ Periodic Inspection and Adjustment
- ④ Fuel System
- ⑤ Power Unit
- ⑥ Jet pump Unit
- ⑦ Electrical System
- ⑧ Hull and Hood
- ⑨ Trouble analysis

Symbols ⑩ to ㉔ indicate specific data:

- ⑩ Special tool
- ⑪ Specified liquid
- ⑫ Specified engine speed
- ⑬ Specified torque
- ⑭ Specified measurement
- ⑮ Specified electrical valve  
[Resistance ( $\Omega$ ), Voltage (V), Electric current (A)]

Symbol ⑯ to ㉔ in an exploded diagram indicate grade of lubricant and location of lubrication point:

- ⑯ Apply Yamaha 2-stroke outboards motor oil
- ⑰ Apply water resistant grease (Yamaha grease A, Yamaha marine grease)
- ⑱ Apply molybdenum disulfide grease

Symbols ⑲ to ㉔ in an exploded diagram indicate grade of sealing or locking agent, and location of application point:

- ⑲ Apply Gasket maker<sup>®</sup>
- ⑳ Apply Yamabond #4 (Yamaha bond No.4)
- ㉑ Apply LOCTITE<sup>®</sup> No. 271 (Red LOCTITE)
- ㉒ Apply LOCTITE<sup>®</sup> No. 242 (Blue LOCTITE)
- ㉓ Apply LOCTITE<sup>®</sup> No. 572
- ㉔ Apply Silicon sealant

**NOTE:** \_\_\_\_\_

In this manual, the above symbols may not be used in every case.

\_\_\_\_\_

# INDEX

**GENERAL INFORMATION**

**SPECIFICATIONS**

**PERIODIC INSPECTION AND  
ADJUSTMENT**

**FUEL SYSTEM**

**POWER UNIT**

**JET PUMP UNIT**

**ELECTRICAL SYSTEM**

**HULL AND HOOD**

**TROUBLE-ANALYSIS**

---

## **CHAPTER 1 GENERAL INFORMATION**

<b>IDENTIFICATION NUMBERS</b> .....	<b>1 - 1</b>
PRIMARY I.D. NUMBER .....	<b>1 - 1</b>
ENGINE SERIAL NUMBER .....	<b>1 - 1</b>
PUMP SERIAL NUMBER .....	<b>1 - 1</b>
HULL IDENTIFICATION NUMBER (H.I.N) .....	<b>1 - 1</b>
<b>SAFETY WHILE WORKING</b> .....	<b>1 - 2</b>
FIRE PREVENTION .....	<b>1 - 2</b>
VENTILATION .....	<b>1 - 2</b>
SELF-PROTECTION .....	<b>1 - 2</b>
OILS, GREASES AND SEALING FLUIDS .....	<b>1 - 2</b>
GOOD WORKING PRACTICES .....	<b>1 - 3</b>
DISASSEMBLY AND ASSEMBLY .....	<b>1 - 4</b>
<b>SPECIAL TOOLS</b> .....	<b>1 - 5</b>
MEASURING .....	<b>1 - 5</b>
REMOVAL AND INSTALLATION .....	<b>1 - 6</b>





AG200C-07

**IDENTIFICATION NUMBERS**

**PRIMARY I.D. NUMBER**

The primary I.D. number is stamped on a label attached to the inside of the engine compartment.

**Starting primary I.D. number:**  
**GP7: 800101 ~, 600101 ~ (EUR)**  
**GP8: 800101 ~, 600101 ~ (EUR)**

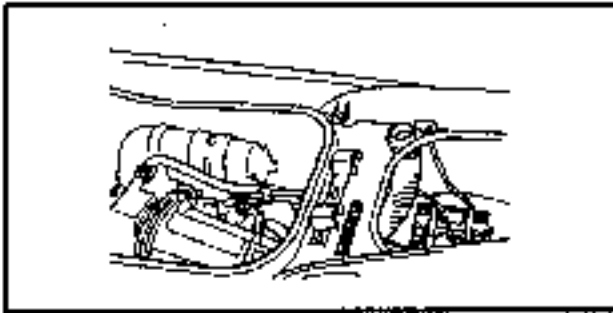

**ENGINE SERIAL NUMBER**

The engine serial number is stamped on a label attached to the crankcase.

**Starting serial number:**  
**65V: 000101 ~**  
**65U: 000101 ~**

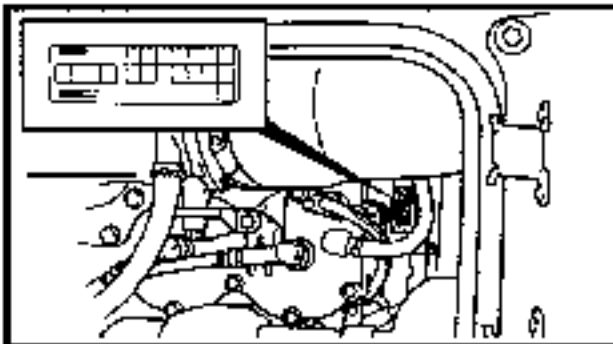

**PUMP SERIAL NUMBER**

The jet pump unit serial number is stamped on a label attached on the intermediate housing.

**Starting serial number:**  
**65V: 500101 ~**

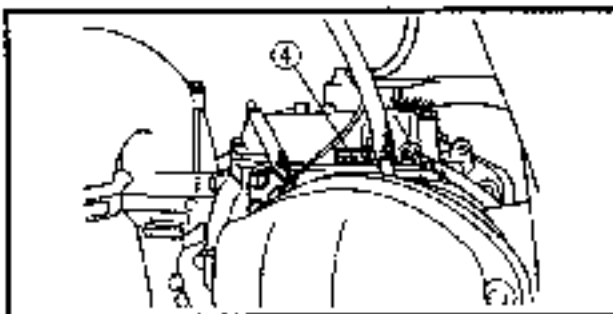

**HULL IDENTIFICATION NUMBER (H.I.N.)**

The H.I.N. is stamped on a plate attached to the hull beside the exhaust outlet.

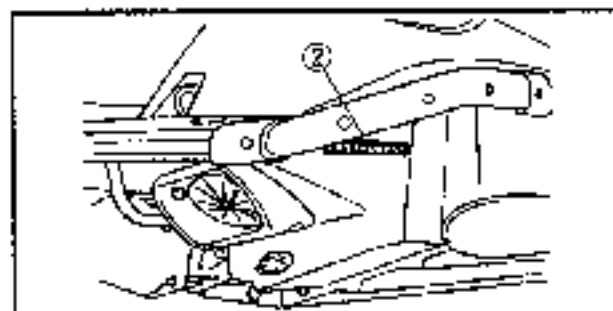
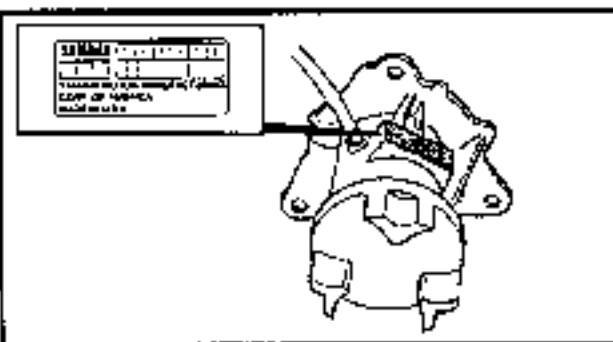

**SAFETY WHILE WORKING**

The procedures given in this manual are those recommended by Yamaha to be followed by Yamaha dealers and their mechanics.



**FIRE PREVENTION**

Gasoline (petrol) is highly flammable. Petroleum vapor is explosive if ignited. Do not smoke while handling gasoline (petrol), and keep it away from heat, sparks, and open flames.

**VENTILATION**

Petroleum vapor is heavier than air and if inhaled in large quantities will not support life. Engine exhaust gases are harmful to breathe. When test-running an engine indoors, maintain good ventilation.



**SELF-PROTECTION**

Protect your eyes with suitable safety spectacles or safety goggles when using compressed air, when grinding or when doing any operation which may cause particles to fly off. Protect hands and feet by wearing safety gloves or protective shoes if appropriate to the work you are doing.



**OILS, GREASES AND SEALING FLUIDS**

Use only genuine Yamaha oils, greases and sealing fluids or those recommended by Yamaha.



Under normal conditions of use, there should be no hazards from the use of the lubricants mentioned in this manual, but safety is all-important, and by adopting good safety practises, any risk is minimized. A summary of the most important precautions is as follows

1. While working, maintain good standards of personal and industrial hygiene.
2. Clothing which has become contaminated with lubricants should be changed as soon as practicable, and laundered before further use.
3. Avoid skin contact with lubricants; do not, for example, place a soiled wiping-rag in one's pocket.
4. Hands, and any other part of the body which have been in contact with lubricants or lubricant-contaminated clothing, should be thoroughly washed with hot water and soap as soon as practicable.
5. To protect the skin, the application of a suitable barrier cream to the hands before working is recommended.
6. A supply of clean lint-free cloths should be available for wiping purposes.



### GOOD WORKING PRACTICES

1. The right tools  
Use the special tools that are designed to protect parts from damage. Use the right tool in the right manner — don't improvise.
2. Tightening torque  
Follow the torque tightening instructions. When tightening bolts, nuts and screws, tighten the larger sizes first, and tighten inner-positioned fixings before outer-positioned ones.

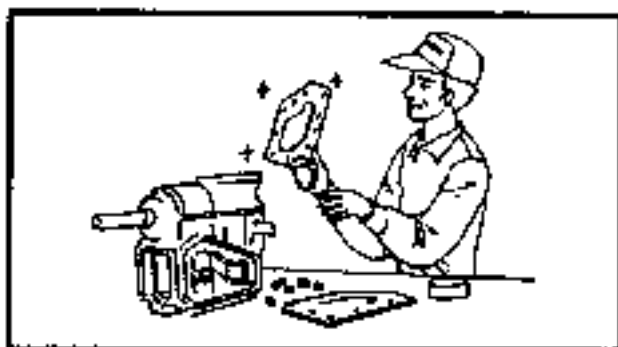
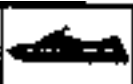

### 3. Non-reusable items

Always use new gaskets, packings, O-rings, oil seals, split-pins and circlips etc. on reassembly.



### DISASSEMBLY AND ASSEMBLY

1. Clean parts with compressed-air on disassembling them.
2. Oil the contact surfaces of moving parts on assembly.

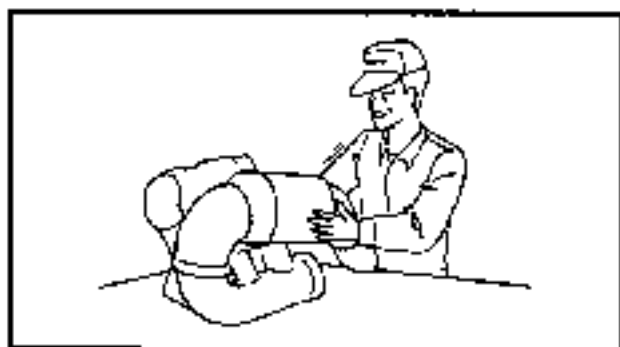

3. After assembly, check that moving parts operate normally.

4. Install bearings with the manufacturer's markings on the side exposed to view, and liberally oil the bearings.

**Do not use compressed air to spin the bearings dry. This causes damage to the bearing surfaces.**

5. When installing oil seals, apply a light coating of water-resistant grease to the outside diameter.



**SPECIAL TOOLS**

Use of the correct special tools recommended by Yamaha will aid the work and enable accurate assembly and tune-up. Improvisations and use of improper tools can cause damage to the equipment.

**NOTE**

- For U.S.A. and Canada, use part numbers starting with "YB-", "YU-" or "YW-".
- For other countries, use part numbers starting with "90890-".

**MEASURING**

1. Dial gauge and stand  
P/N. YU-03097, YU-01256  
90890-01252
2. Digital multi meter  
P/N. YU-34899-A  
90890-06752
3. Pocket tester  
P/N. YU-03112  
90890-03112
4. Compression gauge  
P/N. YU-33223  
90890-06751
5. Cylinder gauge set  
P/N. YU-03017  
90890-06759
6. Engine tachometer  
P/N. YU-08036-A  
90890-06760
7. Spark gap tester  
P/N. YM-34487  
90890-06754

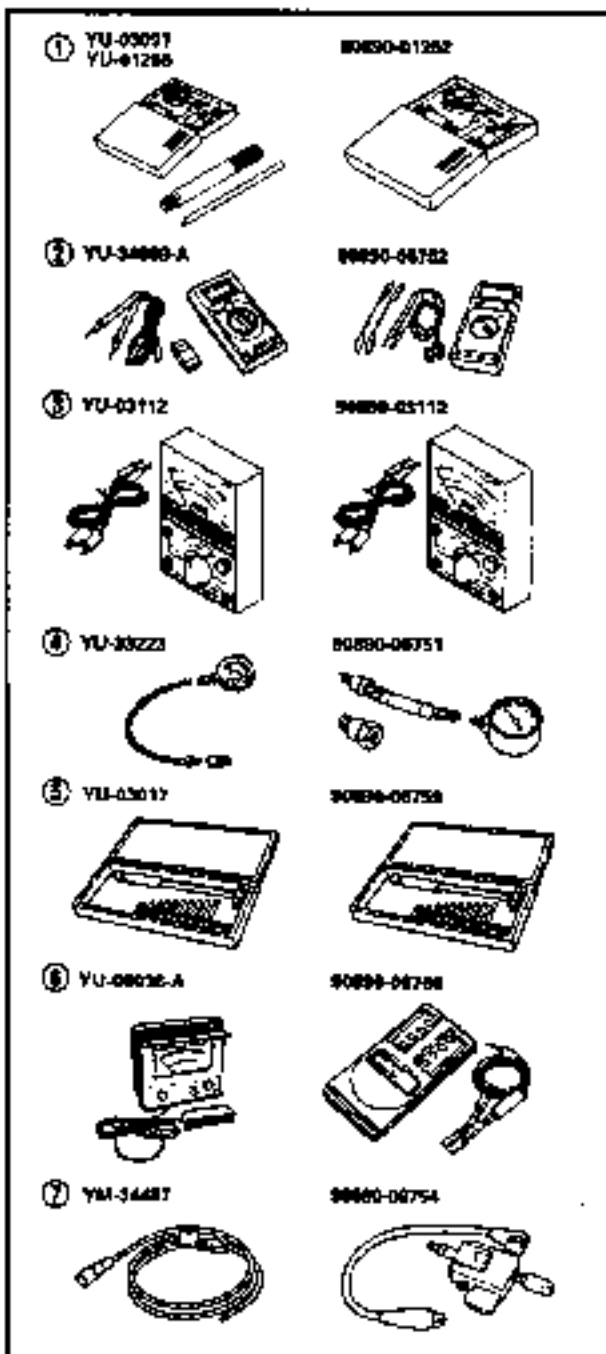

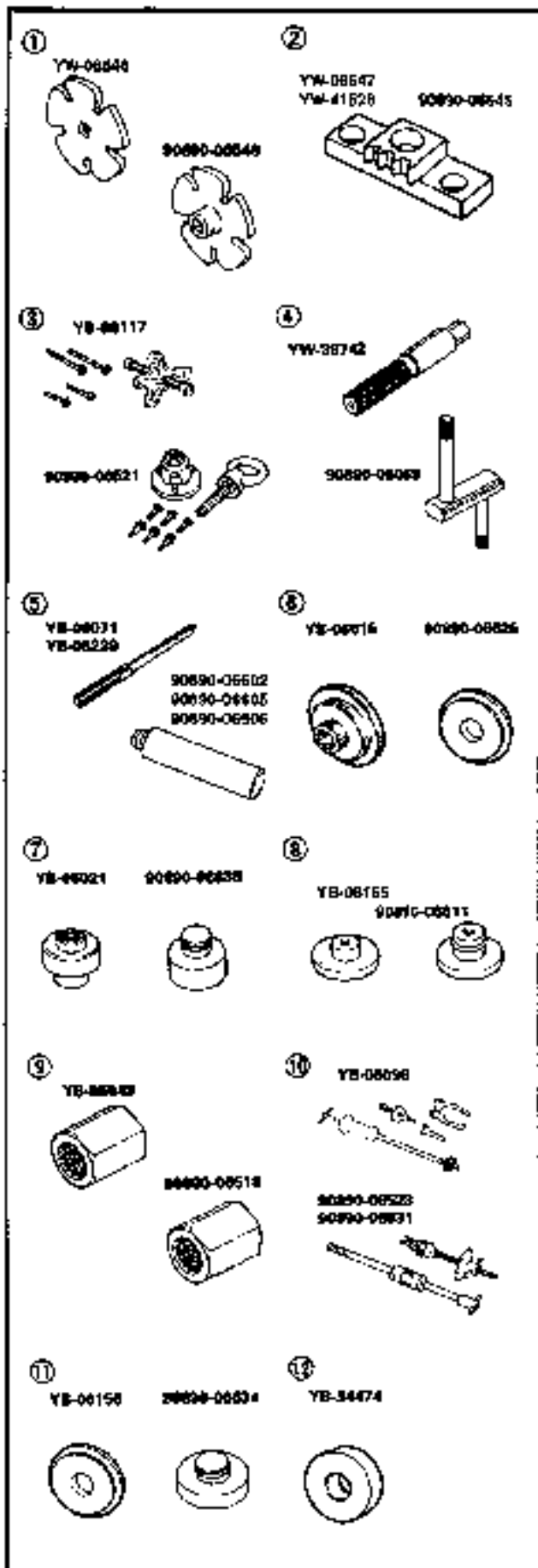

**REMOVAL AND INSTALLATION**

1. Coupler wrench  
P/N. YW-06546  
90890-06546
2. Flywheel holder  
P/N. YW-06547 (GP760)  
YW-41528 (GP1200)  
90890-06547 (GP760)  
90890-06545 (GP1200)
3. Flywheel puller  
P/N. YB-06117  
90890-06521
4. Shaft holder (Intermediate shaft)  
P/N. YW-38742  
90890-06069
5. Driver rod  
(Intermediate shaft and jet pump)  
P/N. YB-06071, YB-06229  
90890-06602  
90890-06605  
90890-06606
6. Bearing outer race attachment  
(Intermediate shaft)  
P/N. YB-06016  
90890-06626
7. Bearing attachment  
(Jet pump bushing and oil seal)  
P/N. YB-06021  
90890-06638
8. Needle bearing attachment  
(Jet pump oil seal)  
P/N. YB-06155  
90890-06611
9. Drive shaft holder (Impeller)  
P/N. YB-06049  
90890-06518
10. Slide hammer set (Jet pump bearing)  
P/N. YB-06098  
90890-06523  
90890-06531
11. Ball bearing attachment  
(Jet pump oil seal)  
P/N. YB-06156  
90890-06634
12. Bearing inner race attachment  
(Jet pump bearing)  
P/N. YB-34474

**CHAPTER 2  
SPECIFICATIONS**

**GENERAL SPECIFICATIONS** ..... 2-1

**MAINTENANCE SPECIFICATIONS** ..... 2-3

**ENGINE** ..... 2-3

**JET UNIT** ..... 2-4

**HULL AND HOOD** ..... 2-5

**ELECTRICAL** ..... 2-5

**TIGHTENING TORQUE** ..... 2-6

**SPECIFIED TORQUE** ..... 2-6

**GENERAL TORQUE** ..... 2-7



## GENERAL SPECIFICATIONS

Item	Unit	Model	
		GP760	GP1200
<b>MODEL CODE:</b>			
Hull		GP7	GP8
Engine		65V	65U
<b>DIMENSIONS:</b>			
Length	mm (in)	2,860 (112.6)	2,860 (112.6)
Width	mm (in)	1,120 (44.1)	1,120 (44.1)
Height	mm (in)	970 (38.2)	970 (38.2)
Dry weight	kg (lb)	214 (472)	238 (525)
Vehicle capacity		2	2
<b>PERFORMANCE:</b>			
Maximum output	kW (HP)/r/min	66.2 (90)/6,350	99.3 (135)/6,750
Maximum fuel consumption	l/h (US gal/h, Imp gal/h)	38 (10.04, 8.36)	53 (14.0, 11.7)
Cruising range	hr.	1.3	1.0
<b>ENGINE:</b>			
Engine type		2-stroke	2-stroke
Number of cylinders		2	3
Displacement	cm <sup>3</sup> (cu. in)	754 (46.0)	1,131 (69.0)
Bore x stroke	mm (in)	84.0 x 68.0 (3.31 x 2.68)	84.0 x 68.0 (3.31 x 2.68)
Compression ratio		F: 7.2, R: 6.8:1	6:1
Intake system		Reed valve	Reed valve
Carburetor type		Mikuni BN44	Mikuni BN44
Number of carburetors		2	3
Enrichment control		Choke valve	Choke valve
Scavenging system		Loop charge	Loop charge
Lubrication system		Oil injection	Oil injection
Cooling system		Water	Water
Starting system		Electric	Electric
Ignition system		Digital CDI	Digital CDI
Ignition timing	Degree	15 BTDC - 22 BTDC	15 BTDC - 22 BTDC
Spark plug (NGK)		BR8HS	BR8HS
Battery capacity	V/kC (A·h)	12 - 68.4 (19)	12 - 68.4 (19)
Lighting coil	A/rpm	3/5,500	5.8 - 7.8/5,000
Propulsion system		Jet pump	Jet pump
<b>DRIVE UNIT:</b>			
Jet pump type		Axial flow single stage	Axial flow single stage
Impeller rotation		Counter clockwise	Counter clockwise
Transmission		Direct drive from engine	Direct drive from engine
Nozzle angle (horizontal)	Degree	23±1	23±1
Nozzle angle (vertical)	Degree	3±12	0±12
Trim system		Manual 5 positions	Manual 5 positions
Reverse system		N/A	N/A





Item	Unit	Model	
		GP760	GP1200
<b>FUEL AND OIL:</b>			
Fuel		Regular unleaded gasoline	Regular unleaded gasoline
Fuel rating	PON <sup>1</sup> /RON <sup>2</sup>	86/90	86/90
Oil		2-stroke outboard motor oil	2-stroke outboard motor oil
Fuel and oil mixing ratio (wide open throttle)		50 : 1	50:1
Fuel tank capacity	l (US gal, Imp gal)	50 (13.2, 11.0)	50 (13.2, 11.0)
Reserve capacity	l (US gal, Imp gal)	8.8 (2.32, .94)	8.8 (2.32, 1.94)
Oil tank capacity	l (US gal, Imp gal)	4 (1.06, 0.88)	4 (1.06, 0.88)

<sup>1</sup>: Pump Octane Number

<sup>2</sup>: Research Octane Number



## MAINTENANCE SPECIFICATIONS

### ENGINE

Item	Unit	Model	
		GP760	GPT1200
Cylinder head: Warpage limit Compression pressure	mm (in) KPa (kg/cm <sup>2</sup> )	0.1 (0.004) —	0.1 (0.004) —
Cylinder: Bore size Taper limit Out of round limit Wear limit	mm (in) mm (in) mm (in) mm (in)	84.00 ~ 84.02 (3.307 ~ 3.308) 0.08 (0.003) 0.05 (0.002) 84.10 (3.311)	84.00 ~ 84.02 (3.307 ~ 3.308) 0.08 (0.003) 0.05 (0.002) 84.10 (3.311)
Piston: Diameter Measuring point* Piston clearance Wear limit Piston pin bore inside diameter	mm (in) mm (in) mm (in) mm (in) mm (in)	83.902 ~ 83.921 (3.3032 ~ 3.3040) 10 (0.39) 0.100 ~ 0.105 (0.0039 ~ 0.0041) 0.155 (0.0061) 20.004 ~ 20.025 (0.7876 ~ 0.7884)	83.902 ~ 83.921 (3.3032 ~ 3.3040) 10 (0.39) 0.100 ~ 0.105 (0.0039 ~ 0.0041) 0.155 (0.0061) 20.004 ~ 20.025 (0.7876 ~ 0.7884)
Piston ring: Top Type Dimensions (B x T) End gap (installed) Ring groove clearance (installed) 2nd Type Dimensions (B x T) End gap (installed) Ring groove clearance (installed)	mm (in) mm (in) mm (in) mm (in)	Keystone 1.5 x 3.2 (0.06 x 0.13) 0.20 ~ 0.40 (0.008 ~ 0.016) 0.02 ~ 0.07 (0.001 ~ 0.003)	Keystone 1.5 x 3.0 (0.06 x 0.12) 0.20 ~ 0.40 (0.008 ~ 0.016) 0.02 ~ 0.07 (0.001 ~ 0.003)
Piston pin: Diameter Wear limit	mm (in) mm (in)	19.995 ~ 20.000 (0.7872 ~ 0.7874) 19.98 (0.786)	19.995 ~ 20.000 (0.7872 ~ 0.7874) 19.98 (0.786)

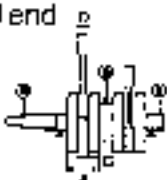

Item	Unit	Model	
		GP760	GP1200
Crankshaft assembly: Crank width "A"  Deflection limit "B" Big end side clearance "C"  Maximum small end axial play "D" 	mm (in)	61.95 - 62.00 (2.439 - 2.441)	61.95 - 62.00 (2.439 - 2.441)
	mm (in)	0.05 (0.002)	0.05 (0.002)
	mm (in)	0.25 - 0.75 (0.010 - 0.030)	0.25 - 0.75 (0.010 - 0.030)
	mm (in)	2.0 (0.08)	2.0 (0.08)
Carburetor: Type Manufacturer Number of carburetors Identification mark Main nozzle (M.N.) Main jet (M.J.) Pilot jet (P.J.)  Low speed screw  Throttle valve Valve seat High speed screw  Trolling speed	mm (in)	Floatless Mikuni 2 65V01/02 3.2 (0.13) 130(01)/132.5(02) 115	Floatless Mikuni 3 65U01/02/03 3.2 (0.13) 135 100 (01)/95 (02)/ 97.5 (03) 1-1/4 (01, 02)/ 1-1/8 (03) ± 1/4 160 1.5 (0.06) 1/2 (01, 03)/ 7/8 (02) ± 1/4 1,300 ± 50
	turns out	1-5/8 ± 1/4	1-1/4 (01, 02)/ 1-1/8 (03) ± 1/4
	mm (in)	160	140
	mm (in)	1.5 (0.06)	1.5 (0.06)
	turns out	3/8 ± 1/4	1/2 (01, 03)/ 7/8 (02) ± 1/4
	r/min.	1,300 ± 50	1,300 ± 50
Reed valve: Thickness Valve stopper height Valve warpage limit	mm (in)	0.4 (0.02)	0.5 (0.02)
	mm (in)	9.0 ± 0.2 (0.35 ± 0.01)	12.5 ± 0.2 (0.49 ± 0.01)
	mm (in)	0.2 (0.01)	0.2 (0.01)

## JET UNIT

Item	Unit	Model	
		GP760	GP1200
Jet pump: Impeller material Number of impeller blades Impeller pitch Impeller clearance  Impeller clearance limit Impeller start runout limit Nozzle diameter		SUS 3 15.5 0.32 - 0.40 (0.013 - 0.016) 0.6 (0.024) 0.3 (0.012) 82.0 (3.228)	SUS 3 15.2 0.25 - 0.35 (0.010 - 0.014) 0.6 (0.024) 0.3 (0.012) 86.0 (3.386)
	degree	15.5	15.2
	mm (in)	0.32 - 0.40 (0.013 - 0.016)	0.25 - 0.35 (0.010 - 0.014)
	mm (in)	0.6 (0.024)	0.6 (0.024)
	mm (in)	0.3 (0.012)	0.3 (0.012)
	mm (in)	82.0 (3.228)	86.0 (3.386)



## HULL AND HOOD

Item	Unit	Model	
		GP760	GP1200
Free play:			
Throttle lever free play	mm (in)	4 - 7 (0.16 - 0.28)	4 - 7 (0.16 - 0.28)
Choke cable free play	mm (in)	1 - 6 (0.04 - 0.24)	1 - 6 (0.04 - 0.24)
Trim control wheel free play	mm (in)	3 - 7 (0.12 - 0.28)	3 - 7 (0.12 - 0.28)

## ELECTRICAL

Item	Unit	Model	
		GP760	GP1200
Battery:			
Type		Fluid	Fluid
Capacity	V/kC (A·h)	12/68.4 (19)	12/68.4 (19)
Ignition timing:			
Ignition timing (at 1,200 r/min)	degree	15 BTDC	15 BTDC
Ignition timing (at 5,500 r/min)	degree	F: 20, R: 18 BTDC	21 BTDC
Stator:			
Pulser coil resistance	Ω (color)	445.5 - 544.5 (W/R - W/B)	248.0 - 372.0 (B-W/R, W/B, W/G)
Charge coil resistance 1	Ω (color)	316.8 - 387.2 (Br - L)	172.0 - 258.0 (B/R - Br)
Charge coil resistance 2	Ω (color)	--	656.0 - 984.0 (L - B/R)
Lighting coil resistance	Ω (color)	1.14 - 1.40 (G - G)	0.56 - 0.84 (G - G)
Charging current (minimum)	A/r/min.	2 - 4/5,500	4 - 6/5,500
Ignition coil:			
Minimum spark gap	mm (in)	9 (0.35)	9 (0.35)
Primary coil resistance	Ω (color)	0.078 - 0.106 (Or - B)	0.048 - 0.072 (B/W - B)
Secondary coil resistance	kΩ (color)	14.3 - 30.5 (High tension cords)	2.7 - 4.1 (High tension cords-B)
Rectifier-regulator:			
Regulate voltage	V	14.3 - 15.3	14.5 - 15.5
Thermo switch:			
On temperature	°C (°F)	90 - 96 (194 - 205)	90 - 96 (194 - 205)
Off temperature	°C (°F)	76 - 90 (169 - 194)	76 - 90 (169 - 194)
Starter motor:			
Brush length	mm (in)	12.5 (0.49)	12.5 (0.49)
Wear limit	mm (in)	6.5 (0.26)	6.5 (0.26)
Comutator undercut	mm (in)	0.7 (0.028)	0.7 (0.028)
Limit	mm (in)	0.2 (0.01)	0.2 (0.01)
Comutator diameter	mm (in)	28.0 (1.10)	28.0 (1.10)
Limit	mm (in)	27 (1.06)	27 (1.06)
Fuse:			
Rating	V-A	12-10	12-10

**TIGHTENING TORQUE  
SPECIFIED TORQUE**

Part to tightened	Part name	Size	Qty		Tightening torque			Remarks	
			760	1200	Nm	m·kg	ft·lb		
<b>ENGINE:</b>									
Electric box	Bolt	M8	2	3	17	1.7	12		
Mounting bolt	Bolt	M8	4	4	17	1.7	12		
Reed valve	Screw	M4	16	24	1	0.1	0.7		
Exhaust ring	Bolt	M8	4	4	30	3.0	22		
Exhaust ring stay	1st	Bolt	M10	3	-	22	2.2	16	
	2nd					40	4.0	29	
Muffler stay	Bolt	M10	4	4	40	4.0	29		
Muffler stay - Muffler 2	1st	Bolt	M10	2	2	2	0.2	1.4	
	2nd					47	4.7	34	
Muffler 2	Bolt	M10	2	2	40	4.0	29		
Muffler 1	1st	Bolt	M10	8	-	22	2.2	16	
	2nd					40	4.0	29	
	1st	Bolt	M8	-	12	15	1.5	11	
	2nd					30	3.0	22	
Cylinder body	1st	Bolt	M10	6	-	23	2.3	17	
	2nd					40	4.0	29	
Cylinder head	1st	Bolt	M8	10	-	15	1.5	11	
	2nd					36	3.6	26	
	1st	Bolt	M8	-	14	15	1.5	11	
	2nd					32	3.2	23	
Cylinder head cover	1st	Bolt	M8	-	15	15	1.5	11	
	2nd					30	3.0	22	
	1st	Bolt	M6	-	2	4	0.4	2.9	
	2nd					8	0.8	5.8	
Spark plug	Bolt	M14	2	3	25	2.5	18		
Flywheel bolt	Bolt	M10	1	1	70	7.0	50		
Crankcase	1st	Bolt	M8	8	12	15	1.5	11	
	2nd					28	2.8	20	
Mount bracket	1st	Bolt	M10	7	7	23	2.3	17	
	2nd					53	5.3	38	
Coupling	Nut	M27	1	1	37	3.7	27		
Frame arrestor cover	Bolt	M6	8	8	2	0.2	1.4		
Starter motor terminal nut	Nut	M6	1	1	5	0.5	3.6		
<b>JET UNIT:</b>									
Mounting bolt	Bolt	M10	4	4	34	3.4	24		
		M6	2	2	12	1.2	8.7		
Ride plate	Bolt	M8	4	4	17	1.7	12		
Impeller (left-hand threads)	Bolt	M20	1	1	18	1.8	13		
Coupling	Nut	M27	1	1	37	3.7	27		
Intermediate housing	Bolt	M8	3	3	17	1.7	12		



Nut Ⓐ	Bolt Ⓑ	General torque specifications		
		Nm	m-kg	ft-lb
8 mm	M5	5.0	0.5	3.6
10 mm	M6	8.0	0.8	5.9
12 mm	M8	18	1.8	13
14 mm	M10	36	3.6	25
17 mm	M12	43	4.3	31

## GENERAL TORQUE

This chart specifies the torques for tightening standard fasteners with standard clean dry ISO threads at room temperature. Torque specifications for special components or assemblies are given in applicable sections of this manual. To avoid causing warpage, tighten multifastener assemblies in a criss-cross fashion, in progressive stages until the specified torque is reached.

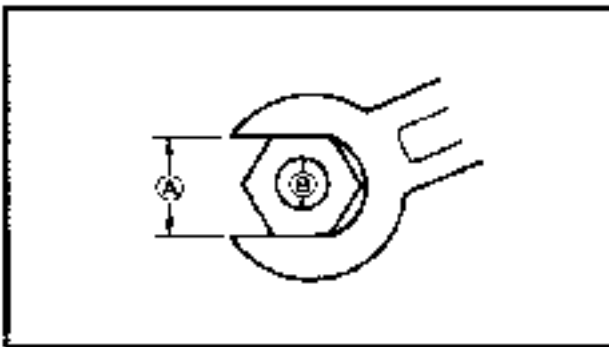

## CHAPTER 3 PERIODIC INSPECTION AND ADJUSTMENT

<b>MAINTANCE INTERVAL CHART</b> .....	3 - 1
<b>PERIODIC SERVICE</b> .....	3 - 2
<b>CONTROL SYSTEM</b> .....	3 - 2
Pivot shaft bearing inspection .....	3 - 2
Steering cable inspection and adjustment .....	3 - 2
Throttle cable inspection and adjustment .....	3 - 3
Choke cable inspection and adjustment .....	3 - 4
Trim cable inspection and adjustment .....	3 - 5
<b>FUEL SYSTEM</b> .....	3 - 7
Fuel filter inspection .....	3 - 7
Trolling speed inspection and adjustment .....	3 - 7
Carburetor adjustment .....	3 - 9
<b>OIL INJECTION SYSTEM</b> .....	3 - 9
Oil filter inspection .....	3 - 9
Oil pump cable inspection and adjustment .....	3 - 9
Oil injection pump air bleeding .....	3 - 10
<b>POWER UNIT</b> .....	3 - 11
Spark plug inspection .....	3 - 11
<b>ELECTRICAL</b> .....	3 - 12
Battery inspection .....	3 - 12
<b>JET PUMP UNIT</b> .....	3 - 14
Impeller inspection .....	3 - 14
Bilge strainer inspection .....	3 - 14
<b>GENERAL</b> .....	3 - 15
Drain plug inspection .....	3 - 15
Greasing point .....	3 - 15



## MAINTANCE INTERVAL CHART

The following chart should be considered strictly as a guide to general maintenance intervals.

Depending on operating conditions, the intervals of maintenance should be changed.

Item	Remarks	Initial		Every		Refer to page
		10 hours (Break-in)	50 hours (3 months)	100 hours (6 months)	200 hours (1 year)	
<b>CONTROL SYSTEM:</b>						
Steering cable	Inspection/Adjustment			○		3-2
Throttle cable	Inspection/Adjustment			○		3-3
Carburetor throttle shaft	Inspection			○		—
Choke cable	Inspection/Adjustment			○		3-4
Trim cable	Inspection/Adjustment			○		3-5
Trim system	Inspection/Adjustment			○		3-5
<b>FUEL SYSTEM:</b>						
Fuel tank	Cleaning				○	4-8
Fuel filter	Cleaning/Replacement	○			○	3-7
Fuel line	Inspection			○		4-1,2
Trolling speed	Inspection/Adjustment			○		3-7
Carburetor setting	Inspection/Adjustment	○		○		3-8
<b>OIL INJECTION SYSTEM:</b>						
Oil injection system	Inspection/Cleaning	○			○	3-9
Oil pump cable	Inspection/Adjustment			○		3-9
<b>POWER UNIT:</b>						
Spark plug	Inspection/Cleaning/Adjustment	○	○	○		3-11
Cooling-water passage	Cleaning/Flashing		○			—
Coupling rubber	Inspection				○	—
<b>ELECTRICAL:</b>						
Battery	Inspection	○				3-12
<b>JET PUMP UNIT:</b>						
Impeller	Inspection		○	○		3-14
Bilge strainer	Cleaning		○	○		3-14
<b>GENERAL:</b>						
Bolt and nut	Tightening	○		○		—
Drain plug	Inspection/Replacement				○	3-15
Greasing point	Greasing			○		3-15
Bearing housing	Greasing	○ *1		○ *2		3-16
Starter motor idle gear	Greasing	○ *3		○ *4		3-16

\*1: Grease capacity 33.0 - 35.0 cm<sup>3</sup> (1.11 - 1.18 oz.)

\*2: Grease capacity 6.0 - 8.0 cm<sup>3</sup> (0.20 - 0.27 oz.)

\*3: Grease capacity 8.0 cm<sup>3</sup> (0.27 oz.)

\*4: Grease capacity 2.0 cm<sup>3</sup> (0.07 oz.)



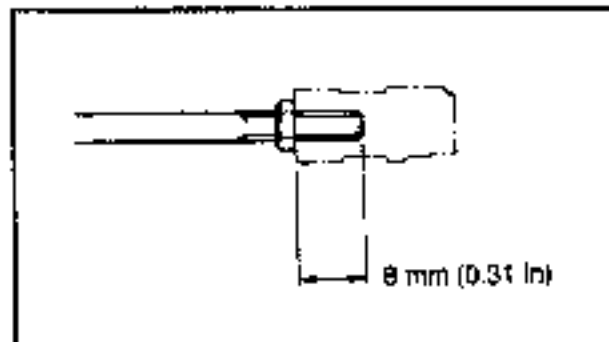
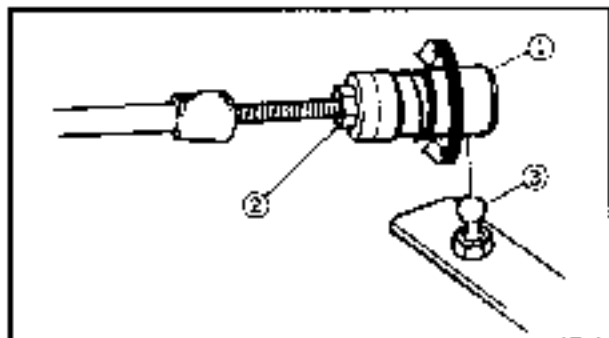
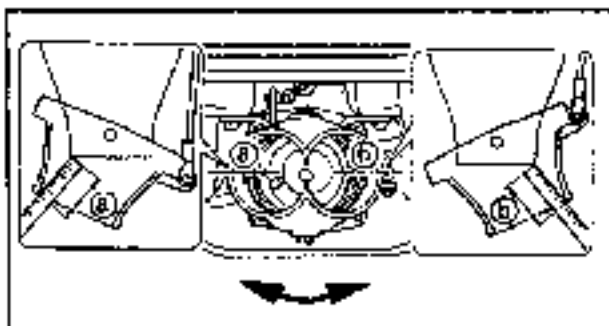
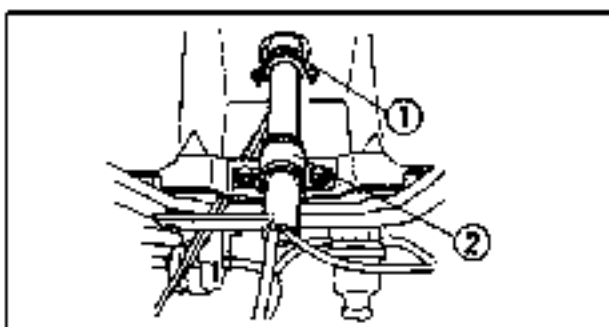
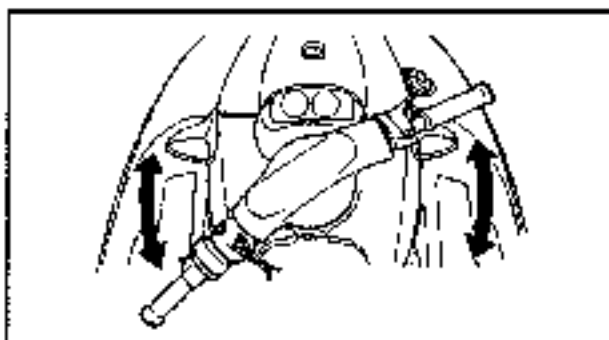

**PERIODIC SERVICE  
CONTROL SYSTEM**

**Pivot shaft bearing inspection**

1. Inspect.
  - Pivot shaft bearing  
Excessive play → Replace bearings.  
Refer to the "STEERING SYSTEM"  
section in chapter B.

**Inspection steps:**

- Move the handlebar up and down.
- Move the handlebar back and forth.

**NOTE:**

Check that the pivot shaft support bolt (1) is secured first.

---

- If the pivot shaft becomes loose, retighten the clamp (2) until a satisfactory feel is obtained.

**Steering cable inspection and adjustment**

1. Inspect:
  - Jet nozzle clearance (a), (b)

**Inspection steps:**

- Turn the handlebar lock to lock.
- Measure the clearances (a) and (b).
- If the (a) and (b) clearances are not even, adjust the clearances.

2. Adjust:
  - Cable joint (handle side) (1)

**Adjustment steps:**

- Loosen the lock nut (2).
- Disconnect the cable joint from the ball joint (3).
- Turn the cable joint to adjust.

Turn in	Clearance (a) is increased.
Turn out	Clearance (b) is increased.

**⚠ WARNING**

The cable joint must be screwed in more than 8 mm (0.31 in).

- Connect the cable joint and tighten the lock nut.

**Lock nut:**  
7 Nm (0.7 m • kg, 5.1 ft • lb)

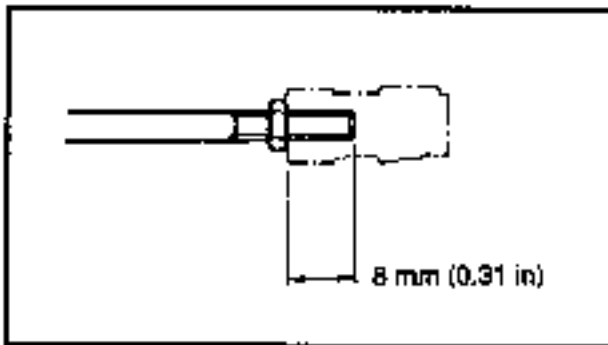

**NOTE:**

If correct adjustment cannot be obtained using the cable joint at the handlebar end adjust the cable joint at the steering nozzle end.

**Throttle cable inspection and adjustment**

**NOTE:**

Before adjusting the throttle lever free play, the trolling speed should be adjusted.

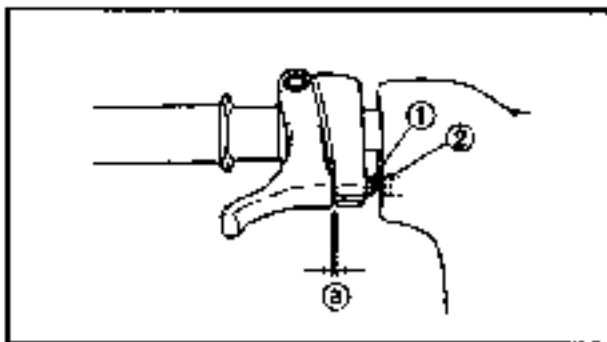

1. Measure:

- Throttle lever free play (3)  
Out of specification → Adjust.



**Throttle lever free play:**  
4 - 7 mm (0.15 - 0.28 in)

2. Adjust:

- Throttle lever free play

**Adjustment steps:**

- Loosen the lock nut (1).
- Turn the adjuster (2) in/out until the specified free play is obtained.

Turn in	Free play is increased.
---------	-------------------------

Turn out	Free play is decreased.
----------	-------------------------

- Tighten the lock nut.

**⚠ WARNING**

After adjusting the free play, turn the handlebar to right and left, and make sure that the trolling speed does not increase.

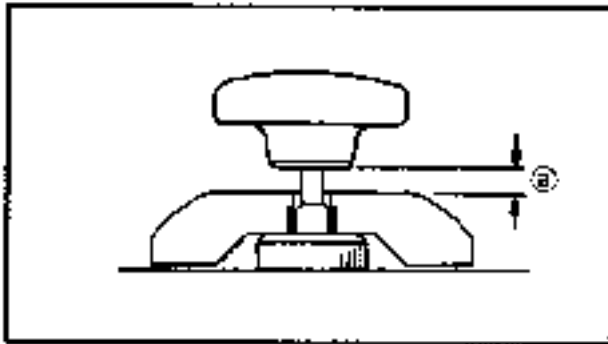
**Choke cable inspection and adjustment**

## 1. Measure:

- Choke cable free play (a)
- Out of specification → Adjust.



**Choke cable free play:**  
1 ~ 6 mm (0.04 ~ 0.24 in)

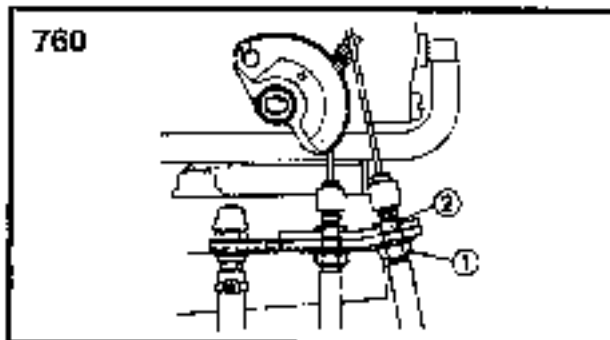

## 2. Adjust:

- Choke cable free play

**Adjustment steps:**

- Loosen the lock nut (1).
- Turn the adjuster (2) in/out until the specified free play is obtained.

Turn in	Free play is increased.
---------	-------------------------

Turn out	Free play is decreased.
----------	-------------------------

- Tighten the lock nut.



**Lock nut:**  
9 Nm (0.9 m • kg, 6.5 ft • lb)

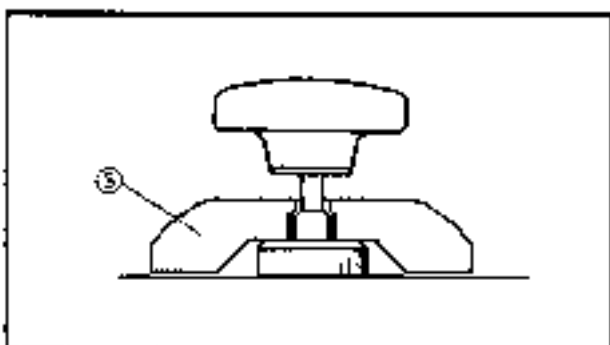
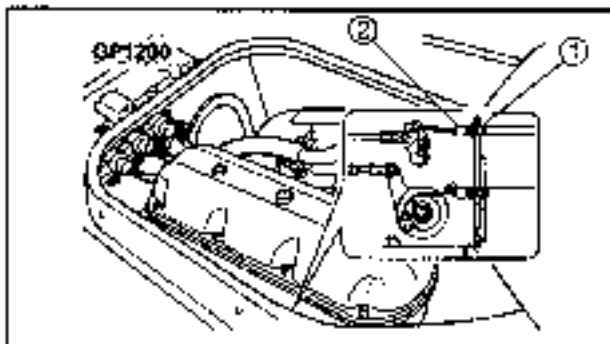

## 3. Inspect:

- Pull knob farthest toward
- Knob automatically returns → Adjust.

## 4. Adjust:

- Adjust nut (3)
- Turn in to stop automatic return.

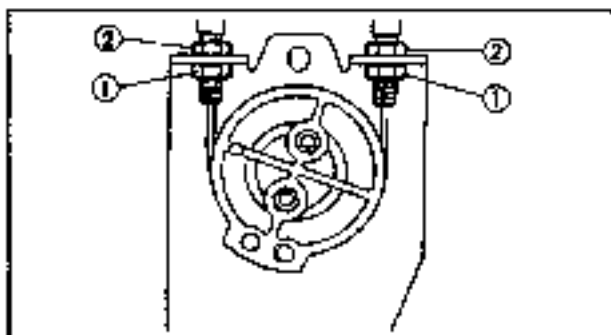
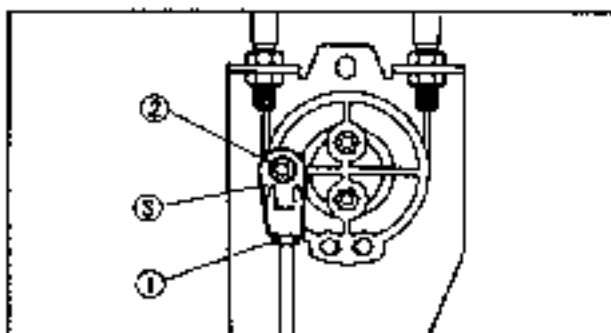
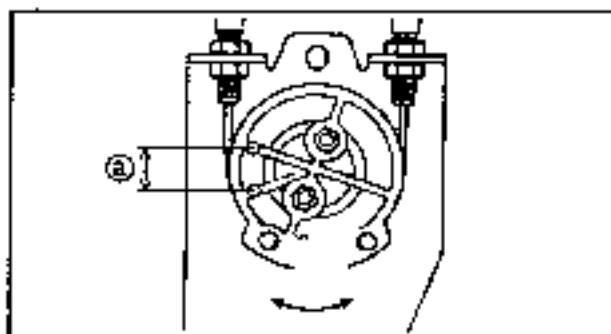

**Trim cable inspection and adjustment**

**1. Measure:**

- Wheel free play (a)  
Out of specification → Adjust.

	<b>Wheel free play (a):</b> 3.0 - 7.0 mm (0.12 - 0.28 in)
--	--

**Measurement steps:**

- Set the trim grip in the neutral position.
- Loosen the lock nut (1).
- Remove the lock nut (2) and cable joint (3).
- Measure free play.

**2. Adjust:**

- Trim control cable 1,2

**Adjustment steps:**

- Set the trim grip in the neutral position.
- Loosen the lock nut (1).
- Turn the adjust nut (2).

Turn in	Clearance is increased.
Turn out	Clearance is decreased.

- Tighten the lock nut.

	<b>Lock nut:</b> 16 Nm (1.6 m • kg, 11 ft • lb)
--	--

**3. Measure:**

- Nozzle deflector set length (a), (b)  
Out of specification → Adjust.

	<b>Nozzle deflector set length (a), (b):</b> (a) = 70±1 mm (2.76±0.04 in) (b) = 70±1 mm (2.76±0.04 in)
--	--

**NOTE:**

- Set the trim grip in the neutral position.
- Set the handlebar in the neutral position.

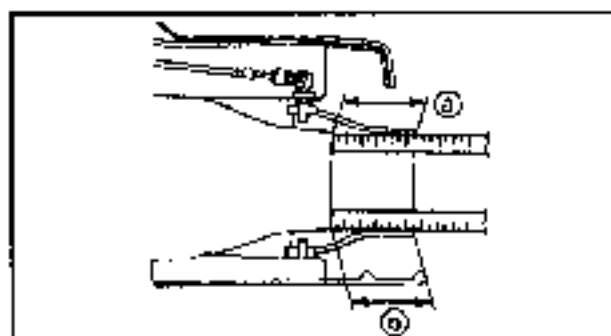

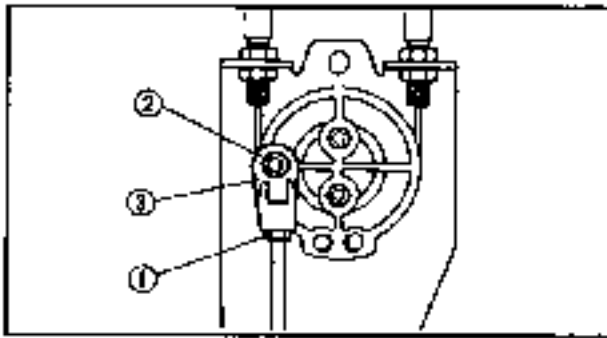

4. Adjust

- Trim control cable

**Adjustment steps:**

- Set the trim grip in the neutral position.
- Set the handlebar in the neutral position.
- Turn the cable joint (3) for adjusting.

Turn in	Length (2) is increased.
---------	--------------------------

Turn out	Length (2) is increased
----------	-------------------------

**⚠ WARNING**

The cable joint must be screwed in more than 8 mm (0.31 in).

- Connect the cable joint and tighten the lock nut (1).
- Tighten the lock nut (2).



**Lock nut:**  
4Nm (0.4 m • kg, 2.9 ft • lb)

**NOTE:**

If correct adjustment by using the cable joint at the wheel end is not obtained, adjust the cable joint on the trim nozzle end.

**FUEL SYSTEM****⚠ WARNING**

- Stop the engine, set the fuel cock to "OFF" and loosen the fuel filler cap before a fuel system service.
- When removing fuel system parts, hold them in a cloth and take care that no fuel spills into the engine compartment.

**Fuel filter inspection**

## 1. Inspect:

- Filter element  
Contamination → Replace.
- Filter body  
Crack/Damage → Replace.
- Filter assembly  
Water contamination → Replace and check the fuel tank.

**Trolling speed inspection and adjustment**

## 1. Check:

- Trolling speed  
Out of specification → Adjust.

	<b>Trolling speed:</b> 1,300 ± 50 r/min
---	--

**Checking steps: (vehicle on water)**

- Start the engine and allow it to warm up for a few minutes.
- Attach the engine tachometer to the spark plug lead.

	<b>Engine tachometer:</b> YU-08036-A/90890-06760
---	---

- Measure the engine trolling speed.



760

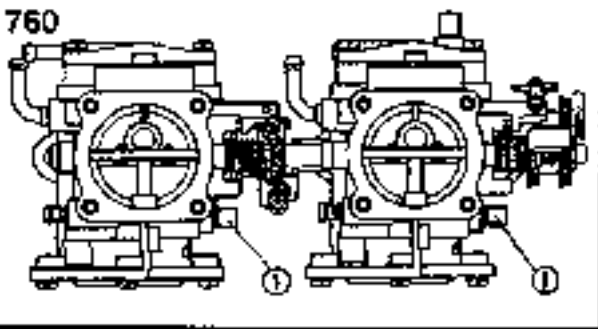

1200

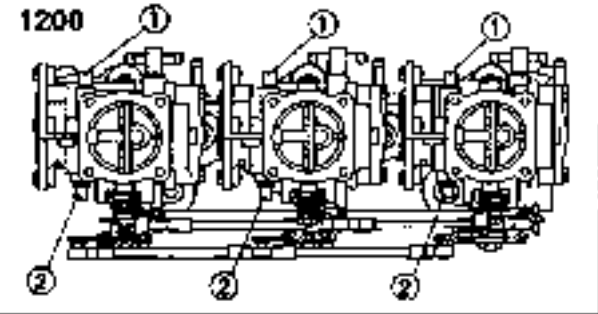

760

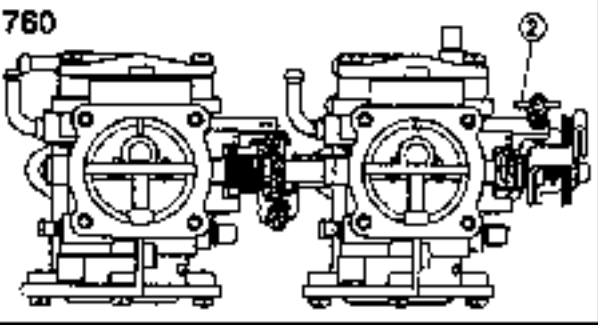

1200

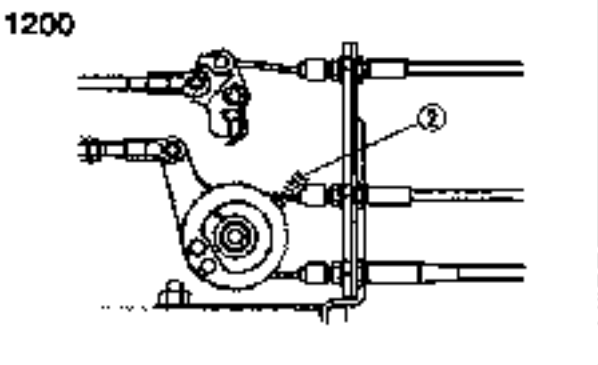

2. Adjust:

- Trolling speed

**Adjustment steps:**

- Screw in the low speed screws (1) until they are lightly seated.
- Back the screws out by the specified number of turns.



**Low speed screw:**

**GP760**

1-5/8 ± 1/4 turns out

**GP1200**

1-1/4 ± 1/4 (#1, #2)

1-1/8 ± 1/4 (#3) turns out

- Start the engine and allow it to warm up for a few minutes.
- Turn the throttle stop screw (2) in or out until the specified speed is obtained.

**Turning in**      Increase trolling speed.

**Turning out**    Decrease trolling speed.



760

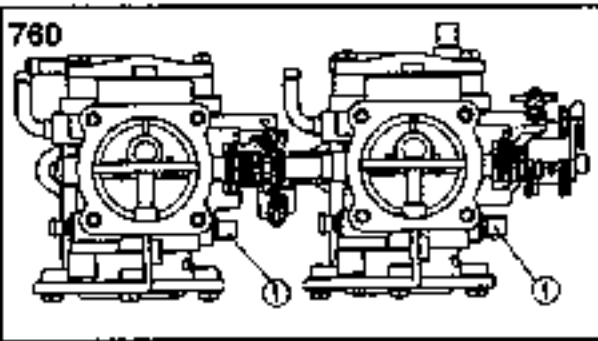

1200

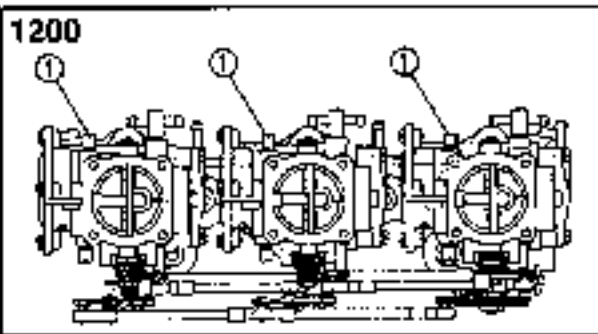
**Carburetor adjustment**

## 1. Adjust:

- High speed screw

**Adjustment steps:**

- Screw in the high speed screws (1) until they are lightly seated.
- Back the screws out by the specified number of turns.

**High speed screw:**

GP760

 $3/8 \pm 1/4$  turns out

GP1200

 $1/2 \pm 1/4$  (#1, #3) $7/8 \pm 1/4$  (#2) turns out**OIL INJECTION SYSTEM****Oil filter inspection**

## 1. Inspect:

- Oil filter  
Fray/Tear → Replace.  
Muddy/Dirt → Clean.
- Seal rubber  
Wear/Crack → Replace.

**Oil pump cable inspection and adjustment (GP1200)**

## 1. Inspect:

- Oil pump lever position  
Incorrect → Adjust.

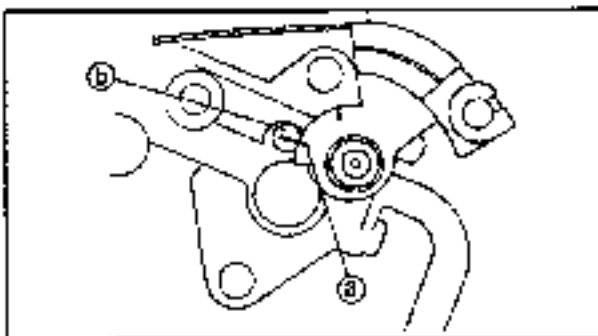
**Checking steps:**

- Fully close the carburetor throttle valve.
- Check that the mark (a) on the pump lever is aligned the mark (b) on the pump body.

## 2. Adjust

- Oil pump cable

**Adjustment steps:**

- Loosen the lock nut (1) and adjust nut (2).
- Fully close the carburetor throttle valve.
- Adjust the oil pump cable so that mark (a) on the pump lever aligns the mark (b) on the pump body.
- Tighten the lock nut.



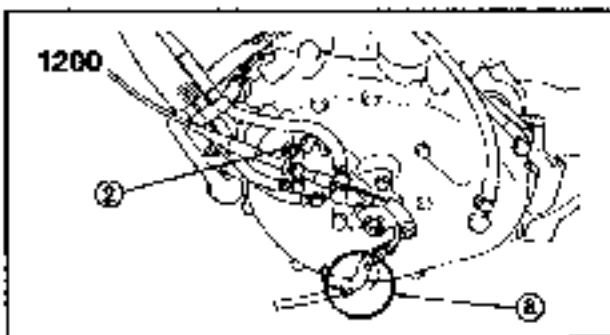
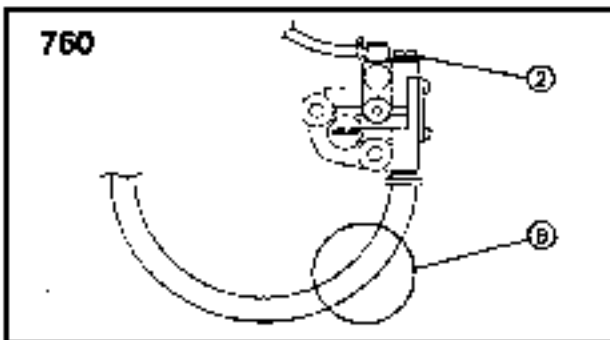
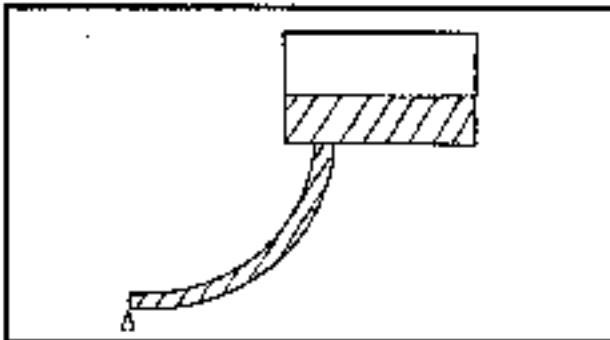
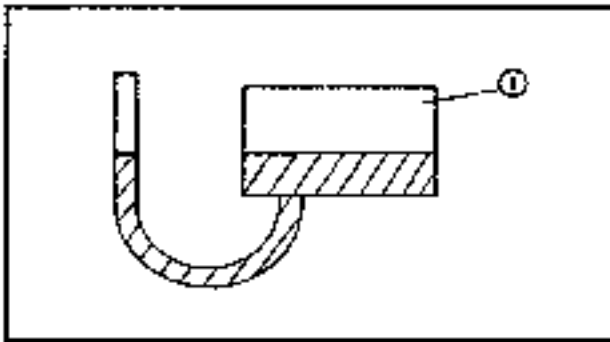

### Oil injection pump air bleeding

#### NOTE:

Bleed the oil injection system if:

- The system has been disassembled.
- The oil has been completely used up during operation.

#### 1. Bleed:

- Air

#### Air bleeding steps:

- a. Place rags under the oil pump to catch any oil that spills out.
- b. Disconnect the oil hose from the oil pump.
- c. Position the oil hose end above the oil tank ①.
- d. Put 2 liters of oil or more in the oil tank and leave it for 2 minutes.
- e. Then, lower the oil hose end and make sure the oil flows out of the oil hose.
- f. Connect the oil hose to the oil pump.
- g. Clamp the oil hose with the hose tie.
- h. Loosen the air bleed screw ② 2 turns, and make sure both oil and air bubbles flow out.
- i. If oil does not come out, squeeze the oil hose ③ near the oil pump inlet a maximum 20 times.
- j. When no air bubbles remain, tighten the air bleed screw.
- k. Wipe out any spilled oil.



Screw:

5 Nm (0.5 m • kg, 3.6 ft • lb)

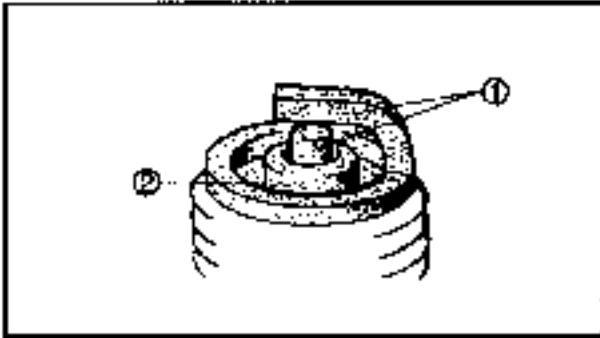
**POWER UNIT****Spark plug inspection**

## 1. Inspect:

- Electrode ①

Wear/Damage → Replace.

Insulator color ②

Discolor → Check the engine condition.

**Color guide:**

**Medium to light tan color:**  
Normal

**Whitish color:**

Lean fuel mixture

Plugged fuel mixture

Air leak

Incorrect settings

**Blackish color:**

Overly rich mixture

Electrical malfunction

Excess oil used

Defective spark plug

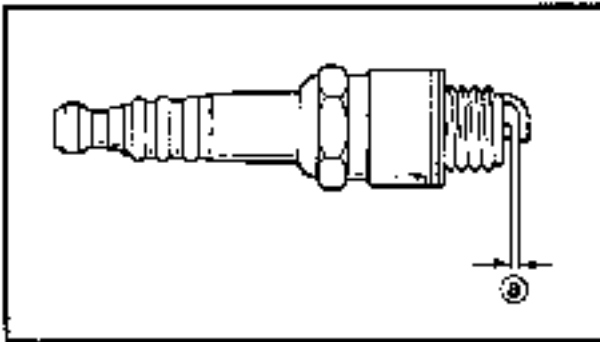

## 2. Clean:

- Spark plug

Clean the spark plug with a spark plug cleaner or wire brush.

## 3. Measure:

- Spark plug gap ③

Out of specification → Alter gap.

Use a wire gauge.

**Spark plug gap:**

0.6 - 0.7 mm (0.024 - 0.028 in)

## 4. Tighten:

- Spark plug

**Spark plug:**

25 Nm (2.5 m • kg, 18 ft • lb)

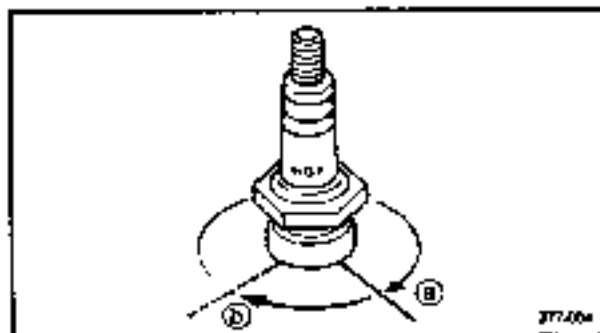
**NOTE:**

- Before installing a spark plug, clean the gasket surface and plug surface. Also it is advisable to apply a thin film of Anti Seize Compound to the spark plug threads to prevent future thread seizure.
- If a torque wrench is not available, a good estimate of the correct torque for the spark plug is a further 1/4 to 1/2 turns (5) on from finger tightness (6).



## ELECTRICAL

### Battery Inspection

Be careful not to place the battery on its side. Before adding the battery fluid or recharging, be sure to remove it from the battery compartment. When checking the battery, make sure the breather hose is connected to the battery and is not pinched shut anywhere in the battery compartment.

#### **⚠ WARNING**

- Battery electrolyte is poisonous and dangerous, causing severe burns, etc. Contains sulfuric acid.
- Avoid contact with skin, eyes or clothing.
- Antidote: **EXTERNAL**-Flush with water.
- **INTERNAL**-Drink large quantities of water or milk. Follow with milk of magnesia, beaten egg or vegetable oil. Call a physician immediately.
- **Eyes**: Flush with water for 15 minutes and get prompt medical attention. Batteries produce explosive gases.
- Keep sparks, flame, cigarettes, etc., away. Ventilate when charging or using in an enclosed space. Always shield your eyes when working near batteries.
- **KEEP OUT OF REACH OF CHILDREN.**

#### 1. Remove:

- Battery

#### **⚠ WARNING**

- When removing the battery, disconnect the negative lead first.
- Remove the battery to prevent acid loss during the impeller service.

#### 2. Inspect:

- Battery fluid level  
Battery fluid level low → Top up with distilled water.  
Fluid level should be between upper ① and lower ② level marks.

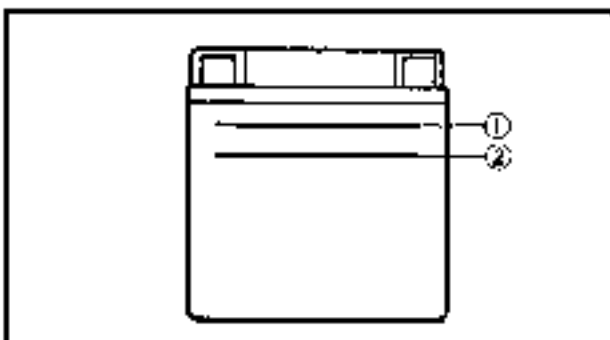

**Filling steps:**

- Remove each filler cap using pliers.
- Fill with distilled water using a jug.
- When the acid is up to the **UPPER LEVEL**, allow the cell to stand for 20 minutes. If the acid level has dropped, add more acid up to the **UPPER LEVEL** once again.

**Water other than distilled water contains minerals which are harmful to a battery; top up only with distilled water.**

**3. Inspect:**

- Battery fluid specific gravity  
Out of specification → Charge.



**Specific gravity at 20°C (68°F):**

**1.28**

**Charging current:**

**68.4 kc. (1.9 Amps × 10 hrs)**

**4. Install:**

- Filler cap

**Rinse off any acid from the battery case and wipe the battery dry prior to installation.**

**5. Install:**

- Breather hose ①
- Battery
- Positive lead ②
- Negative lead ③
- Battery band

- Connect the positive red lead ② to the battery terminal first.
- Make sure the battery leads are connected properly. Reversing the leads can seriously damage the electrical system.
- Make sure the breather hose is properly connected and is not obstructed.
- Coat the terminals with a water resistant grease to minimize terminal corrosion.

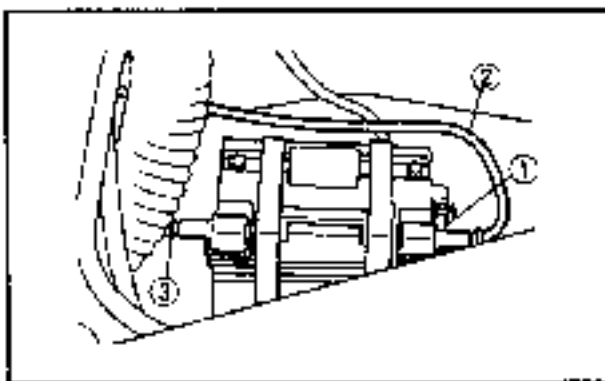

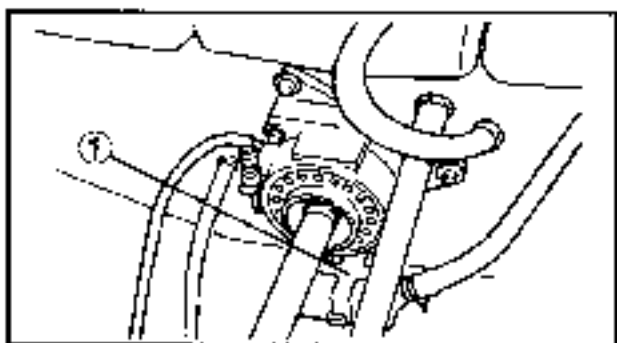
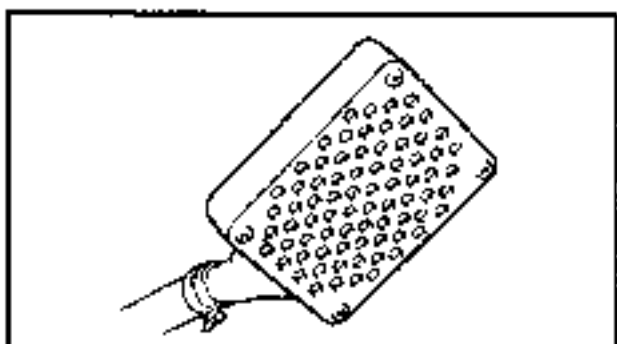
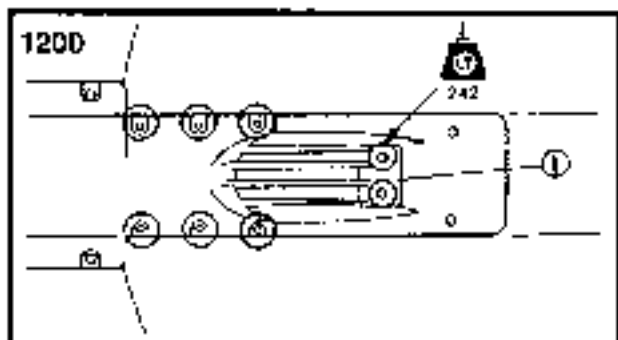
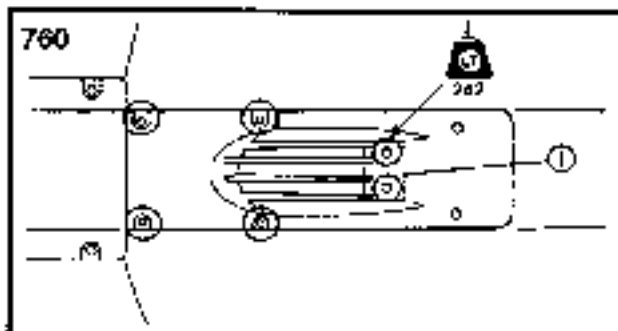
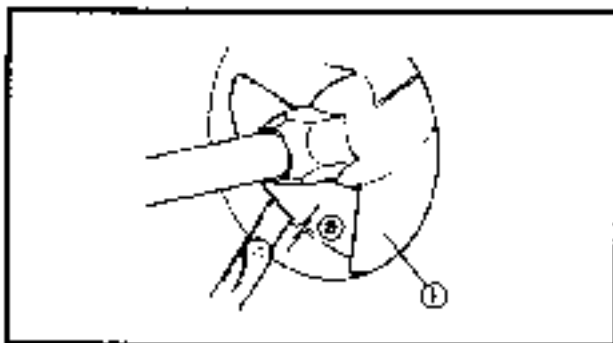

## JET PUMP UNIT

### Impeller inspection

#### 1. Check:

- Impeller ①
  - Wear/Damage → Replace.
  - Scratch/Nick → File/Grind.

#### 2. Measure:

- Impeller clearance (a)
  - Out of specification → Replace.



**Impeller clearance limit:**  
0.6 mm (0.024 in)

#### Measurement steps:

- Remove the battery.
- Remove the intake screen ①.
- Measure the clearance at all four points.
- Install the intake screen.

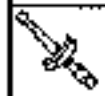

**Bolt:**  
11 Nm (1.1 m • kg, 8.0 ft • lb)

- Install the battery.

### Bilge strainer inspection

#### 1. Inspect:

- Strainer
  - Contamination → Clean.
  - Crack/Damage → Replace.

#### Inspection steps:

- Remove the coupling cover.
- Disconnect the bilge strainer ① from the strainer holder.
- Inspect the bilge strainer.

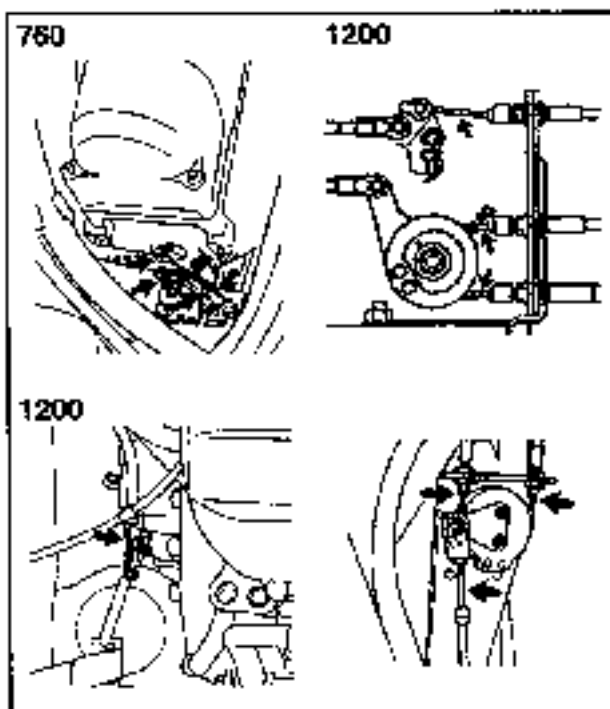
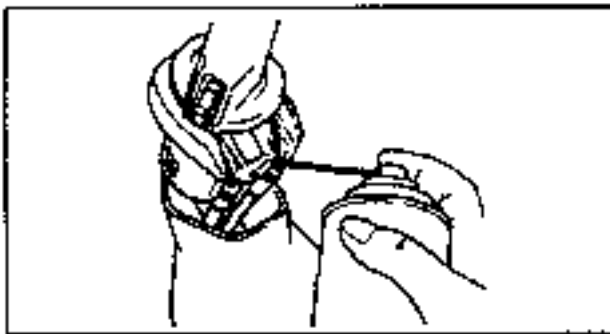
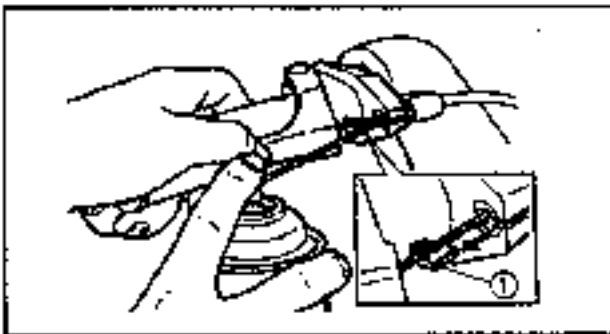
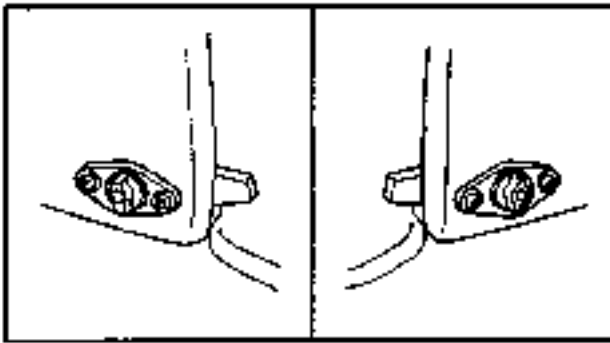

## GENERAL

### Drain plug inspection

#### 1. Inspect:

- Drain plug  
Crack/Damage → Replace.
- O-ring  
Crack/Wear → Replace.
- Screw threads  
Dirt/Sandy → Clean.

### Greasing point

#### 1. Apply:

- Throttle cable inner wire
- Trim control cable inner wire



**Recommended fluid:**  
**Rust-inhibitor**

### NOTE:

- Squeeze the throttle lever and remove the seal (1).
- Remove the trim grip cover.
- Spray a rust-inhibitor into the outer cable.

#### 2. Apply

- Throttle cable inner wire
- Choke cable inner wire
- Oil pump cable inner wire (GP1200)
- Trim control cable inner wire



**Recommended grease:**  
**Water resistant grease**

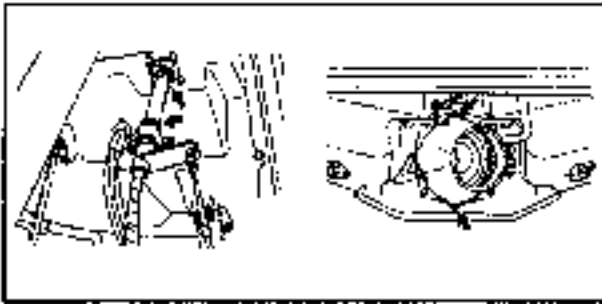

## 3. Apply

- Steering pivot shaft bushing
- Nozzle pivot shaft collar



**Recommended grease:  
Water resistant grease**

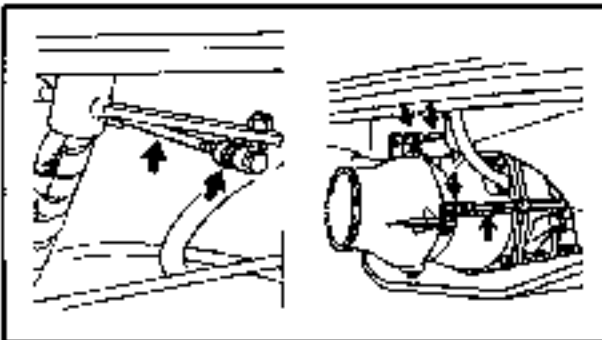

## 4. Apply:

- Steering cable
- Trim control cable shaft
- Cable joint



**Recommended grease:  
Water resistant grease**

**NOTE:**

Disconnect the cable joint and apply a small amount of grease to the following parts.

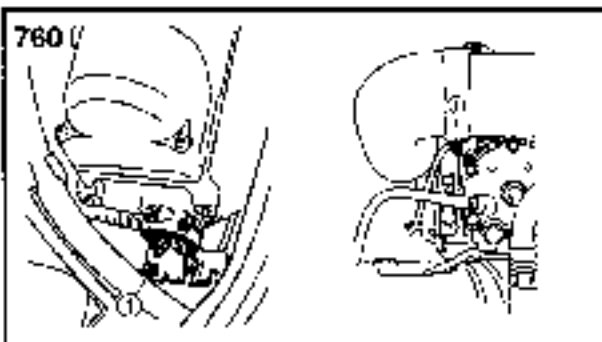

## 5. Fill

- Bearing housing
- Starter idle gear

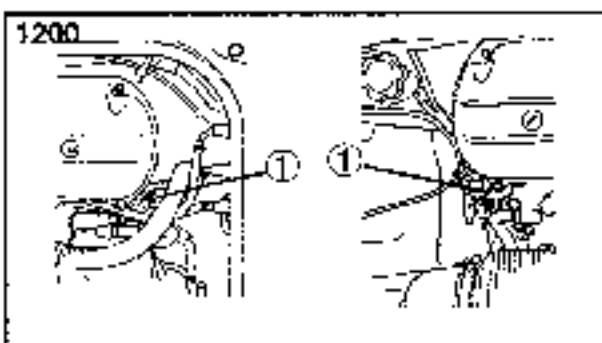

**Recommended grease:  
Water resistant grease**

**NOTE:**

- Fill in the bearing housing and the starter idle gear with water resistant grease through the grease nipples (1).
- Fill the grease slowly and carefully, as it can damage the hose and the joints.
- Refer to the "MAINTENANCE INTERVAL CHART".

**CHAPTER 4  
FUEL SYSTEM**

<b>FUEL LINE</b> .....	4 - 1
EXPLODED DIAGRAM (GP760).....	4 - 1
REMOVAL AND INSTALLATION CHART.....	4 - 1
EXPLODED DIAGRAM (GP1200).....	4 - 2
REMOVAL AND INSTALLATION CHART.....	4 - 2
SERVICE POINTS.....	4 - 3
Fuel filter inspection.....	4 - 3
Fuel cock inspection.....	4 - 3
<b>OIL TANK</b> .....	4 - 4
EXPLODED DIAGRAM.....	4 - 4
REMOVAL AND INSTALLATION CHART.....	4 - 4
SERVICE POINTS.....	4 - 5
Check valve inspection.....	4 - 5
Oil filter inspection.....	4 - 5
Oil level sensor inspection.....	4 - 5
Oil tank inspection.....	4 - 5
<b>FUEL TANK REMOVAL</b> .....	4 - 6
EXPLODED DIAGRAM.....	4 - 6
REMOVAL AND INSTALLATION CHART.....	4 - 6
<b>FUEL TANK</b> .....	4 - 7
EXPLODED DIAGRAM.....	4 - 7
REMOVAL AND INSTALLATION CHART.....	4 - 7
SERVICE POINTS.....	4 - 8
Check valve inspection.....	4 - 8
Fuel level sensor.....	4 - 8
Fuel tank inspection.....	4 - 8
Pipe joint inspection.....	4 - 8
Pipe joint installation.....	4 - 8
<b>CARBURETOR UNIT REMOVAL</b> .....	4 - 9
EXPLODED DIAGRAM (GP760).....	4 - 9
REMOVAL AND INSTALLATION CHART.....	4 - 9
EXPLODED DIAGRAM (GP1200).....	4 - 10
REMOVAL AND INSTALLATION CHART.....	4 - 10





<b>CARBURETOR REMOVAL</b> .....	4 - 11
EXPLODED DIAGRAM .....	4 - 11
REMOVAL AND INSTALLATION CHART .....	4 - 11
SERVICE POINTS .....	4 - 12
Throttle valve synchronization inspection and adjustment .....	4 - 12
Choke valve synchronization inspection and adjustment (GP760) .....	4 - 13
<b>CARBURETOR</b> .....	4 - 14
EXPLODED DIAGRAM .....	4 - 14
REMOVAL AND INSTALLATION CHART .....	4 - 14
SERVICE POINTS .....	4 - 15
Diaphragm inspection .....	4 - 15
Float arm inspection .....	4 - 15
Body assembly inspection .....	4 - 15
Needle valve inspection .....	4 - 15
Jet and carburetor body inspection .....	4 - 16
High and low speed screws inspection .....	4 - 16
High and low speed screws adjustment .....	4 - 16
Carburetor assembly .....	4 - 16
<b>FUEL PUMP</b> .....	4 - 17
EXPLODED DIAGRAM .....	4 - 17
REMOVAL AND INSTALLATION CHART .....	4 - 17
SERVICE POINTS .....	4 - 18
Fuel pump inspection .....	4 - 18
Filter inspection .....	4 - 18
<b>OIL LINE</b> .....	4 - 19
EXPLODED DIAGRAM .....	4 - 19
REMOVAL AND INSTALLATION CHART .....	4 - 19
SERVICE POINTS .....	4 - 19
Check valve inspection .....	4 - 19
<b>OIL PUMP</b> .....	4 - 20
EXPLODED DIAGRAM .....	4 - 20
REMOVAL AND INSTALLATION CHART .....	4 - 20
SERVICE POINTS .....	4 - 21
Oil pump inspection .....	4 - 21
Oil hose inspection .....	4 - 21
Ring rubber inspection .....	4 - 21
Ring rubber installation .....	4 - 21



**WARNING**

Gasoline (Petrol) is highly flammable and explosive. Handle with special care.

**FUEL LINE  
EXPLODED DIAGRAM (GP760)**

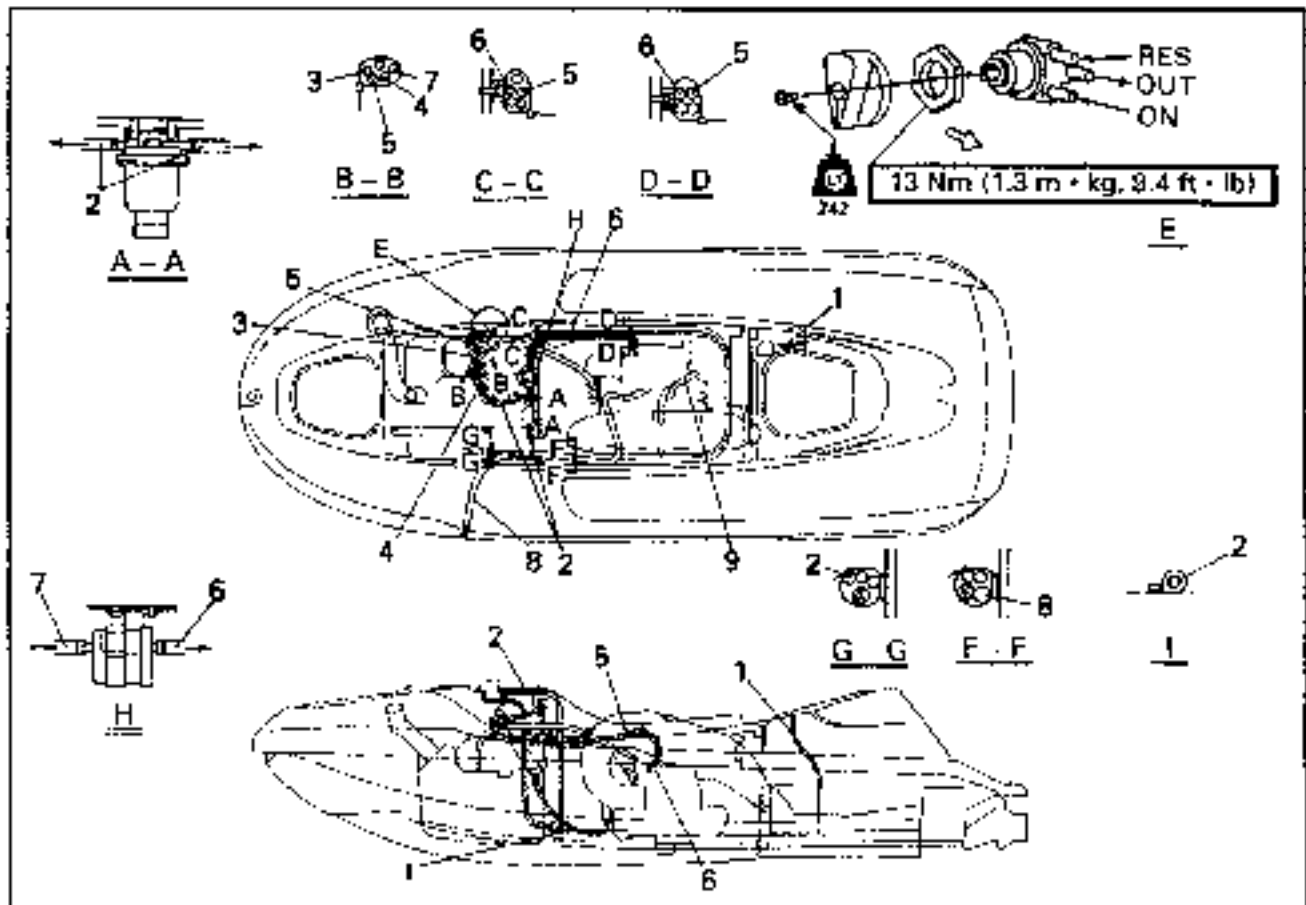

**REMOVAL AND INSTALLATION CHART**

Step	Procedure/Part name	Qty	Service points
	<b>FUEL HOSE REMOVAL</b>		Follow the left "Step" for removal.
	Fuel cock		<b>NOTE:</b> Turn the fuel cock to "OFF".
1	Battery breather hose	1	
2	Air ventilation hose	3	
3	Fuel hose (ON)	1	
4	Fuel hose (RES)	1	
5	Fuel hose (carburetor - fuel tank)	1	
6	Fuel hose (filter - carburetor)	1	
7	Fuel hose (OUT)	1	
8	Pilot water hose	1	
9	Cooling water hose	1	
			Reverse the removal steps for installation.



**WARNING**

Gasoline (Petrol) is highly flammable and explosive. Handle with special care.

**FUEL LINE  
EXPLODED DIAGRAM (GP1200)**

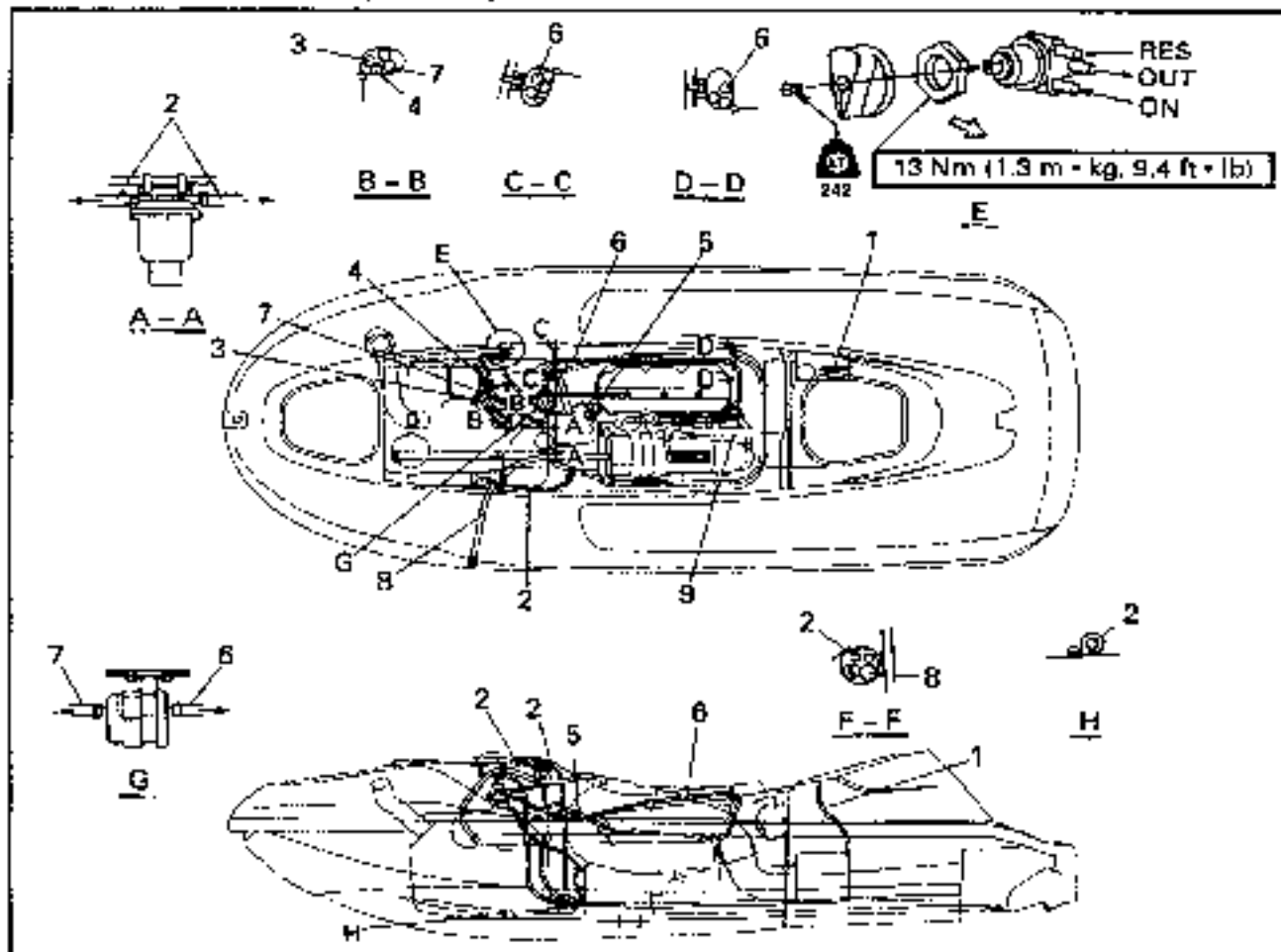

**REMOVAL AND INSTALLATION CHART**

Step	Procedure/Part name	Q'ty	Service points
	<b>FUEL HOSE REMOVAL</b>		Follow the left "Step" for removal.
	Fuel cock		<b>NOTE:</b> Turn the fuel cock to "OFF".
1	Battery breather hose	1	
2	Air ventilation hose	3	
3	Fuel hose (ON)	1	
4	Fuel hose (RES)	1	
5	Fuel hose (carburetor - fuel tank)	1	
6	Fuel hose (filter - carburetor)	1	
7	Fuel hose (OUT)	1	
8	Pilot water hose	1	
9	Cooling water hose	1	
			Reverse the removal steps for installation.

**SERVICE POINTS****Fuel filter inspection**

Refer to the "FUEL SYSTEM" section in chapter 3.

**Fuel cock inspection**

## 1. Check:

## ● Fuel cock

Unsmooth movement → Replace.

Clug → Clean.



## OIL TANK EXPLODED DIAGRAM

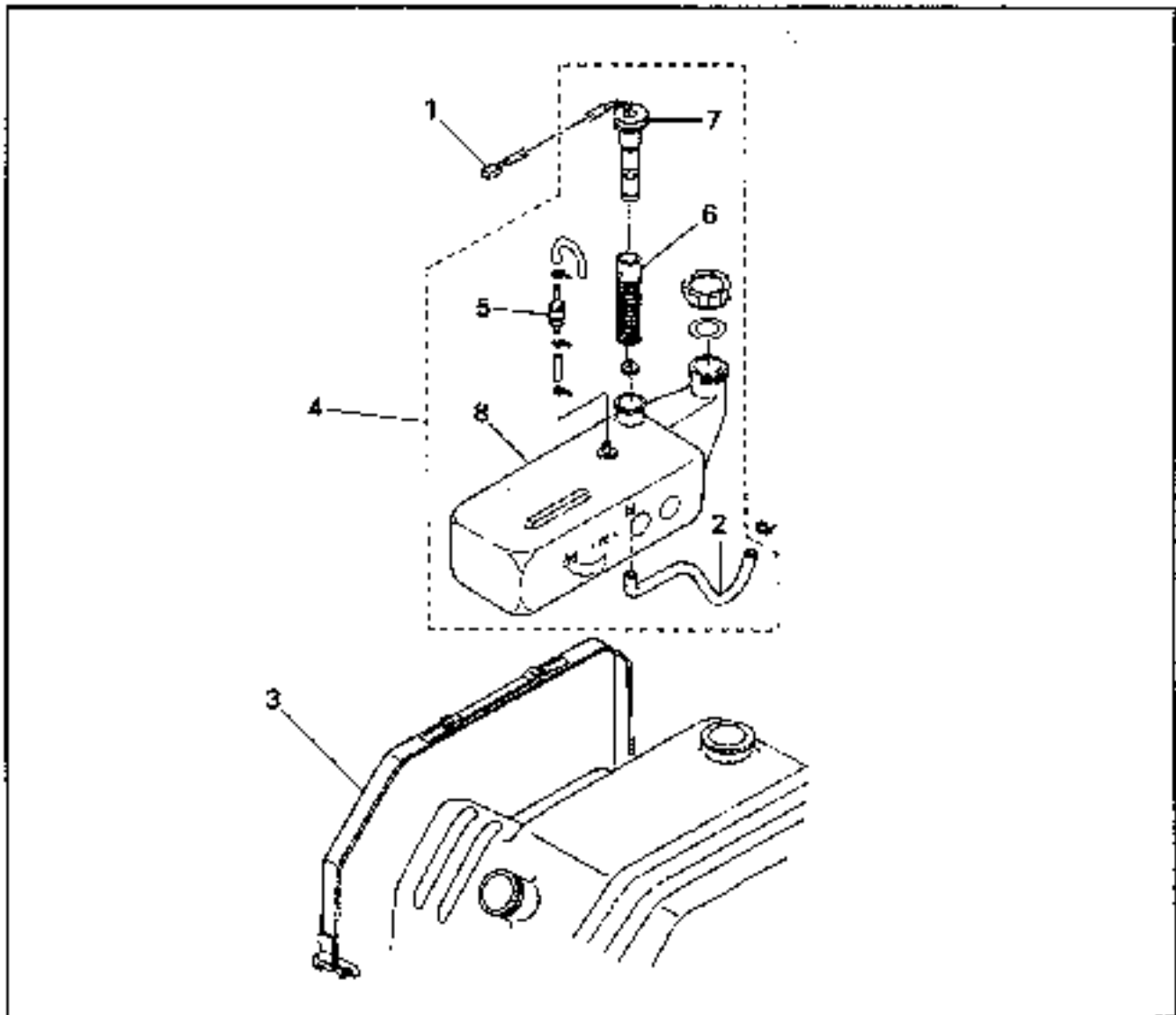

### REMOVAL AND INSTALLATION CHART

Step	Procedure/Part name	Q'ty	Service points
	<b>OIL TANK REMOVAL</b>		Follow the left "Step" for removal.
1	Oil level sensor lead coupler	1	
2	Oil hose	1	
3	Tank band	1	
4	Oil tank assembly	1	
5	Check valve	1	
6	Oil filter	1	
7	Oil level sensor	1	
8	Oil tank	1	
			Reverse the removal steps for installation.

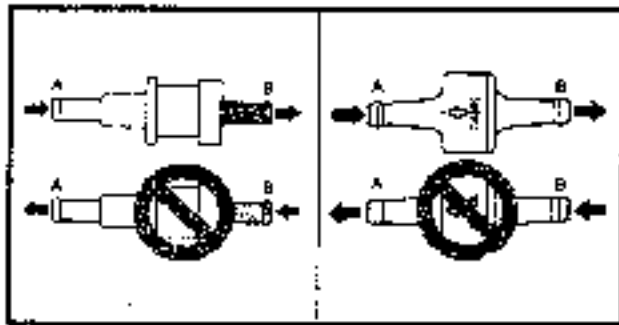

**SERVICE POINTS**

**Check valve inspection**

- 1. Check:
  - Check valveOut of specification → Replace.

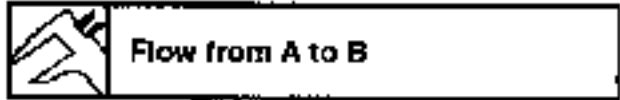

**Oil filter inspection**

Refer to "OIL INJECTION SYSTEM" in chapter 3.

**Oil level sensor inspection**

Refer to "INDICATION SYSTEM" in chapter 7.

**Oil tank inspection**

- 1. Inspect:
  - Oil tankCrack/Damage → Replace.



FUEL TANK REMOVAL  
EXPLODED DIAGRAM

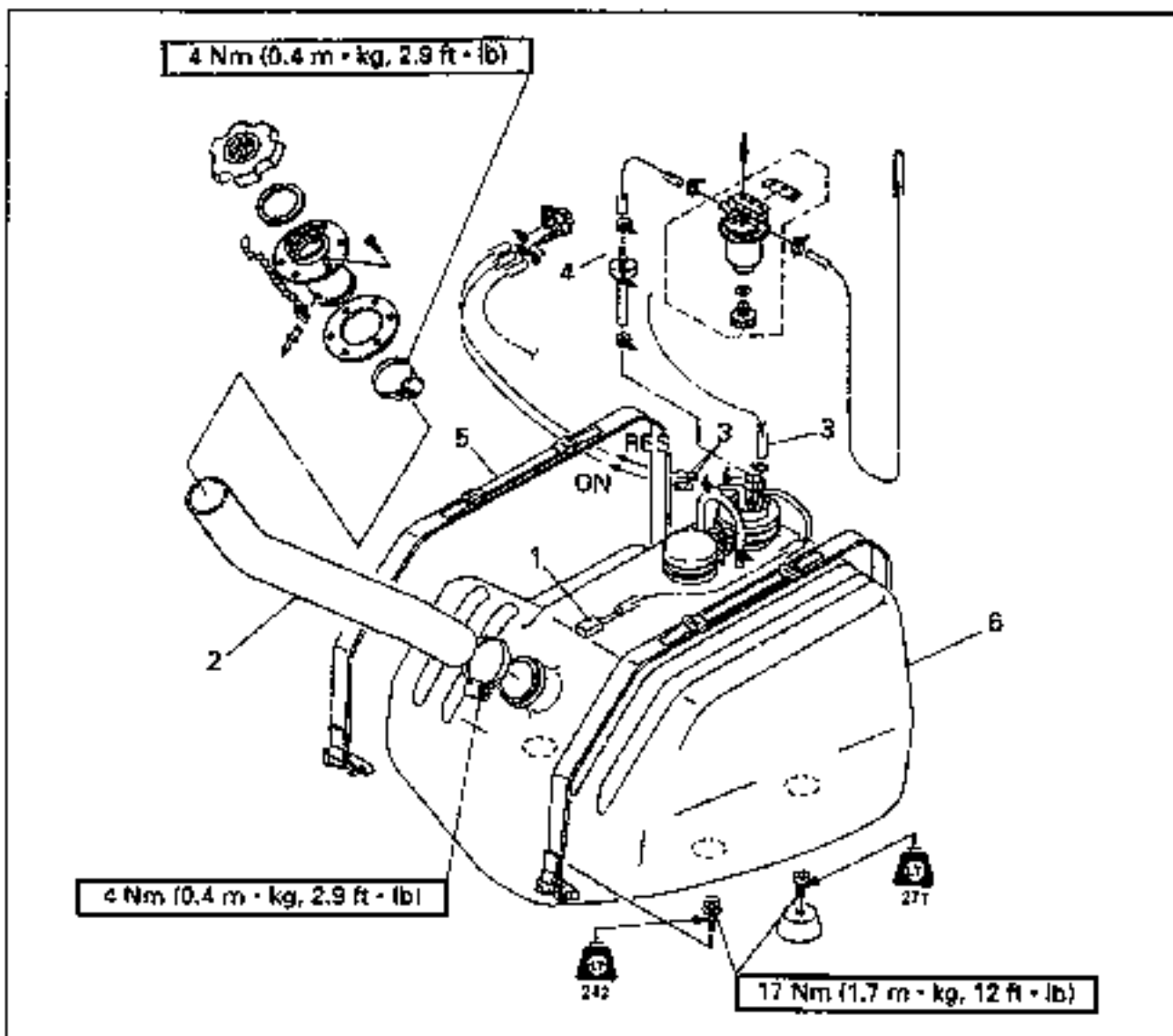

REMOVAL AND INSTALLATION CHART

Step	Procedure/Part name	Q'ty	Service points
	<b>FUEL TANK REMOVAL</b>		
	Engine unit		Follow the left "Step" for removal. Refer to "ENGINE UNIT REMOVAL" in chapter 5.
	Oil tank assembly		Refer to "OIL TANK".
1	Fuel level sensor lead coupler	1	
2	Fuel filter hose	1	<b>NOTE:</b> _____
3	Fuel hose	3	Drain the fuel.
4	Air ventilation hose	1	
5	Tank band	2	
6	Fuel tank assembly	1	
			Reverse the removal steps for installation.

**FUEL TANK  
EXPLODED DIAGRAM**

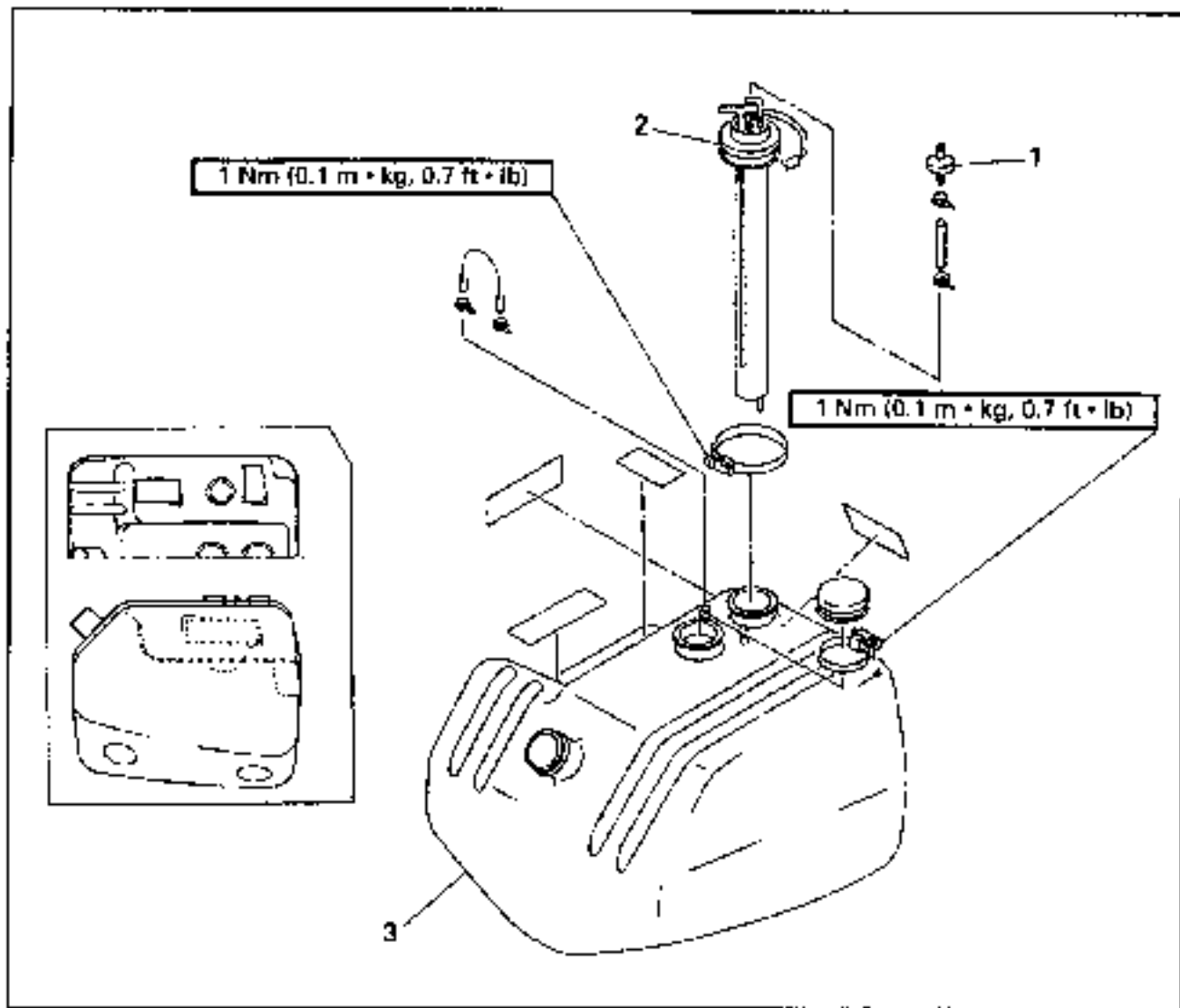

**REMOVAL AND INSTALLATION CHART**

Step	Procedure/Part name	Q'ty	Service points
	<b>FUEL TANK DISASSEMBLY</b>		
	Fuel tank disassembly		Follow the left "Step" for removal. Refer to "FUEL TANK REMOVAL"
1	Check valve	1	
2	Pipe joint assembly	1	
3	Fuel tank	1	
			Reverse the removal steps for installation.



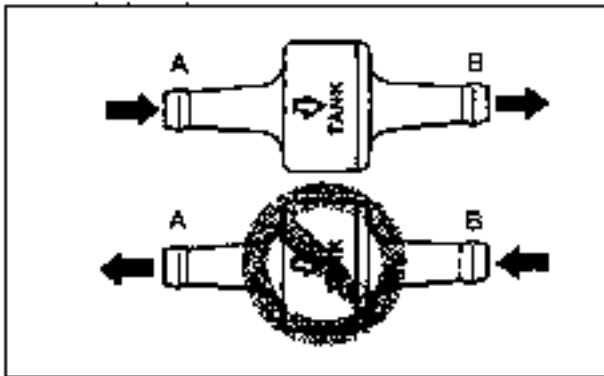

### SERVICE POINTS

#### Check valve inspection

1. Check:
  - Check valve
  - Out of specification → Replace.



Flow from A to B

#### Fuel level sensor inspection

Refer to the "INDICATION SYSTEM" section in chapter 7.

#### Fuel tank inspection

1. Inspect:
  - Oil tank
  - Fuel tank
  - Crack/Damage → Replace.

#### Pipe joint inspection

1. Inspect:
  - Pipe
  - Bending/Damage → Replace.
  - Contamination → Clean.
  - Pipe joint
  - Wear/Crack → Replace.

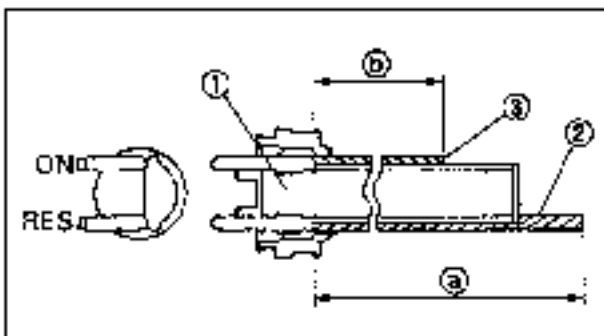

#### Pipe joint installation

1. Install:
  - Pipe joint ①
  - Pipe ②:
  - Pipe ③:



Length ②:  
 $372.5 \pm 2 \text{ mm (14.7} \pm 0.08 \text{ in)}$   
 Length ③:  
 $352.5 \pm 2 \text{ mm (13.8} \pm 0.08 \text{ in)}$



**CARBURETOR UNIT REMOVAL**  
**EXPLODED DIAGRAM (GP760)**

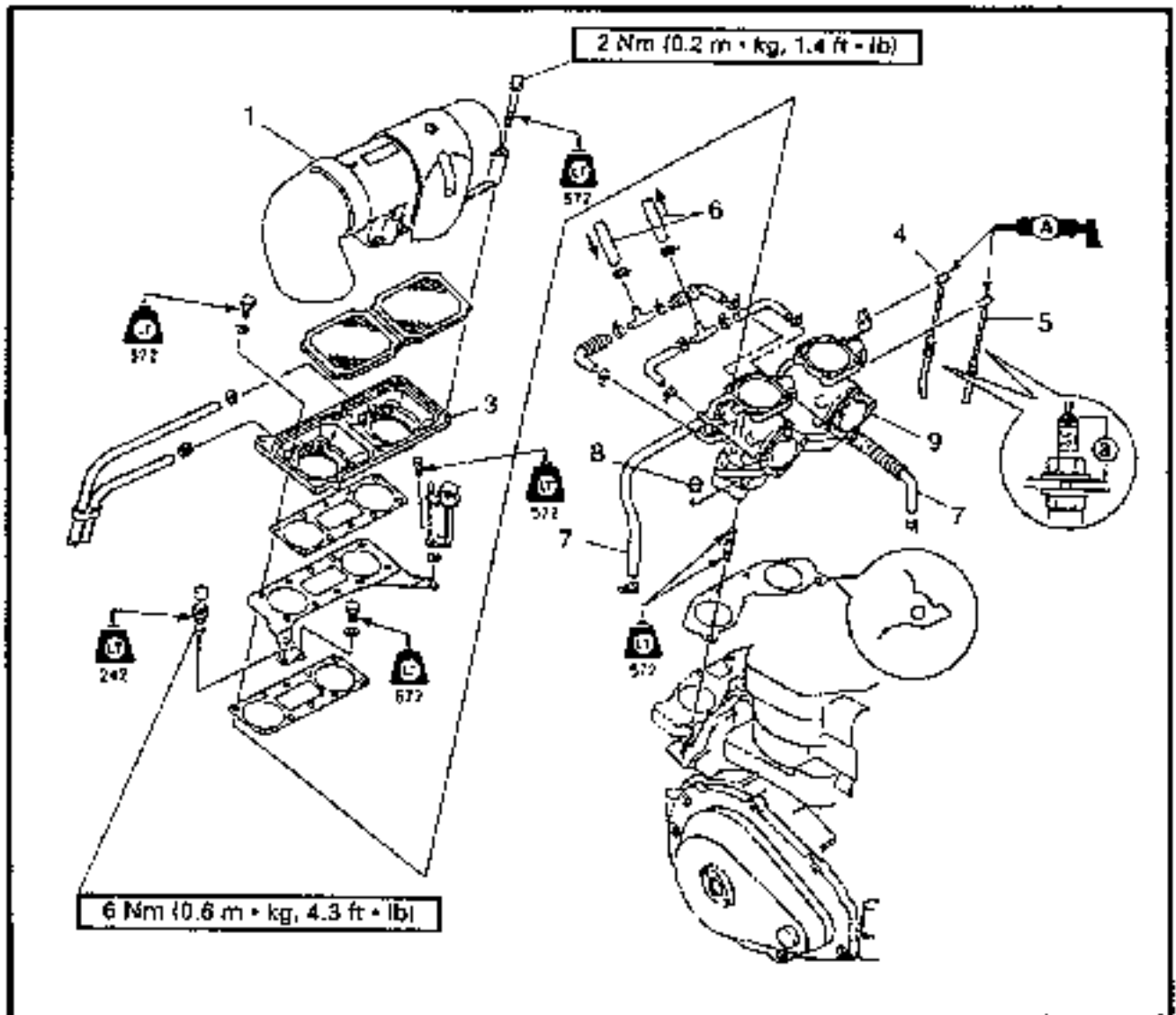

**REMOVAL AND INSTALLATION CHART**

Step	Procedure/Part name	Q'ty	Service points
<b>CARBURETOR REMOVAL</b>			
1	Carburetor cover	1	Follow the left "Step" for removal.
2	Flame arrester	2	
3	Carburetor cover	1	
4	Choke cable	1	
5	Throttle cable	1	
6	Fuel hose	2	Reverse the removal steps for installation.
7	Pulse hose	2	
8	Nut	4	
9	Carburetor assembly	1	

**Cable guide set position (B):**  
**17 mm (0.67 in)**



EXPLODED DIAGRAM (GP1200)

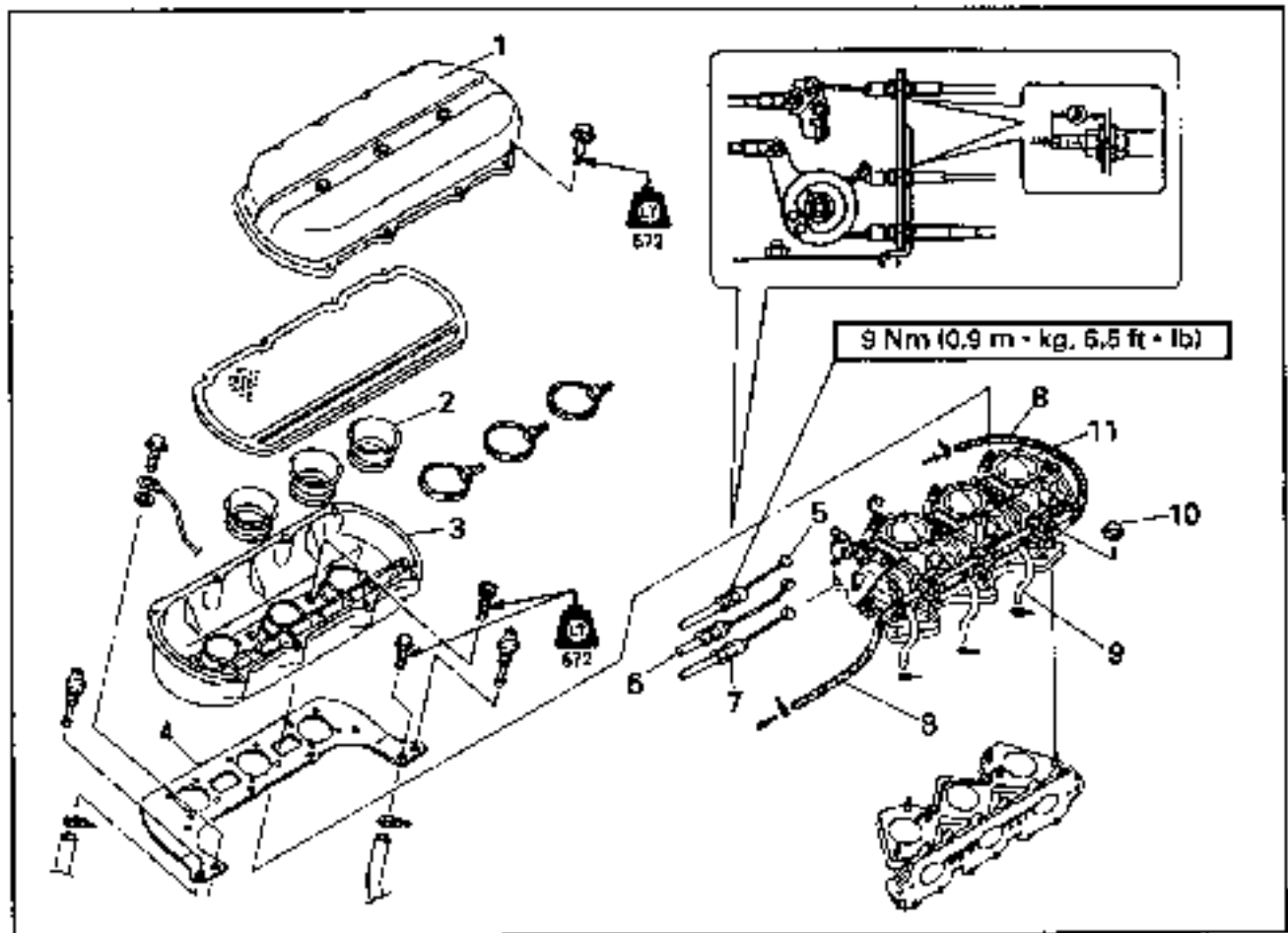

REMOVAL AND INSTALLATION CHART

Step	Procedure/Part name	Qty	Service points
<b>CARBURETOR REMOVAL</b>			Follow the left "Step" for removal.
1	Carburetor cover 1	1	<p><b>Choke cable guide set position @:</b> 14 mm (0.55 in) <b>Throttle cable guide set position @:</b> 17 mm (0.67 in)</p>
2	Funnel	3	
3	Carburetor cover 2	1	
4	Plate	1	
5	Choke cable	1	
6	Throttle cable	1	
7	Oil pump cable	1	
8	Fuel hose	2	
9	Pulse hose	3	
10	Nut	6	
11	Carburetor unit	1	
			Reverse the removal steps for installation.



## CARBURETOR REMOVAL

### EXPLODED DIAGRAM

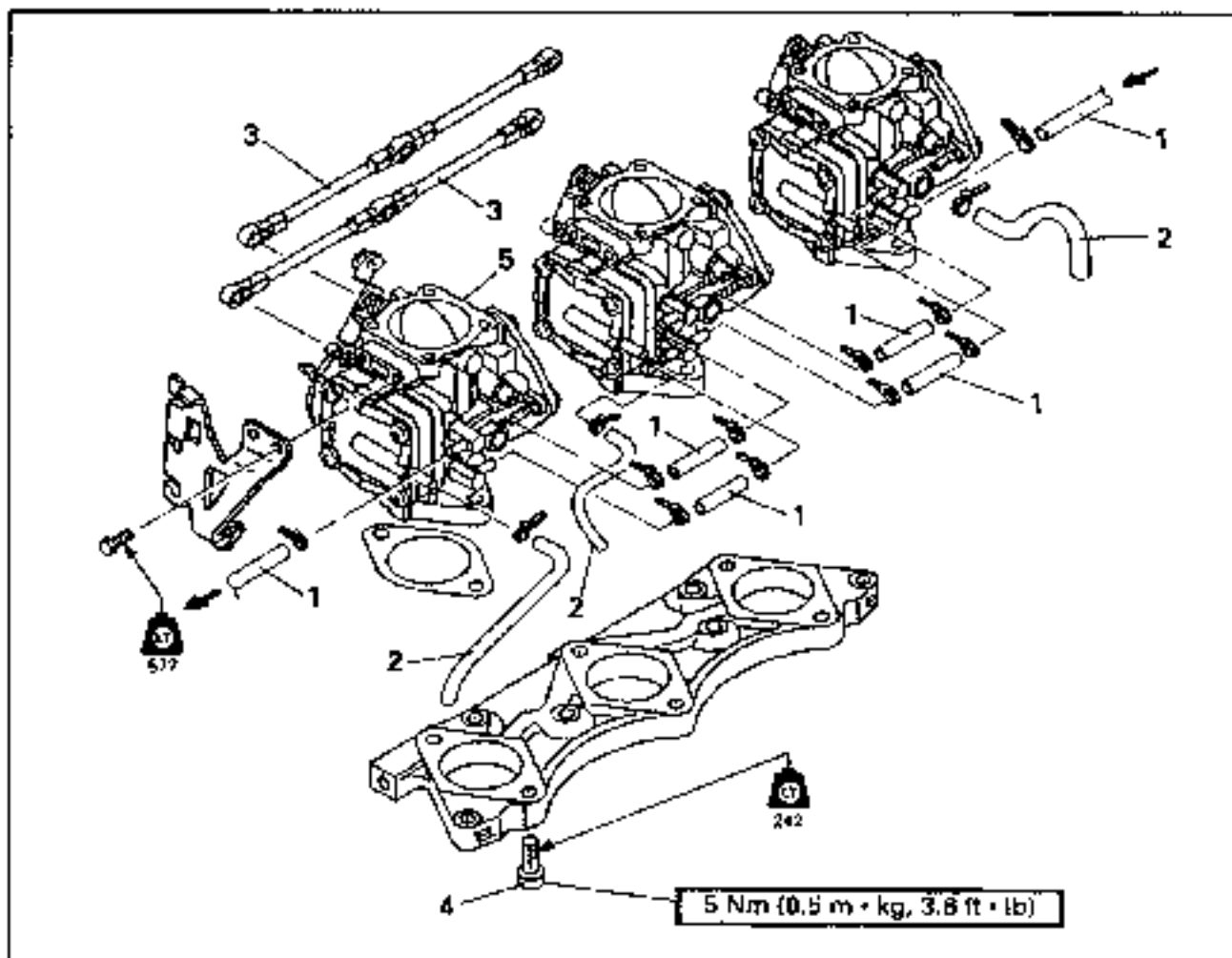

### REMOVAL AND INSTALLATION CHART

Step	Procedure/Part name	Q'ty	Service points
	<b>CARBURETOR ASSEMBLY</b>		
	Carburetor unit	1	Follow the left "Step" for removal. Refer to "CARBURETOR UNIT REMOVAL".
1	Fuel hose	4, 6	
2	Pulse hose	2, 3	
3	Link joint	-, 2	
4	Bolt	4, 6	
5	Carburetor assembly	2, 3	
			Reverse the removal steps for installation.

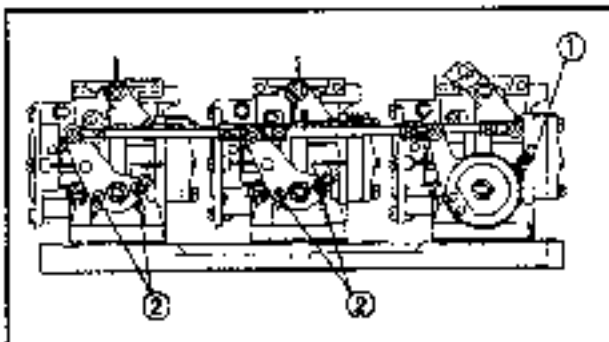
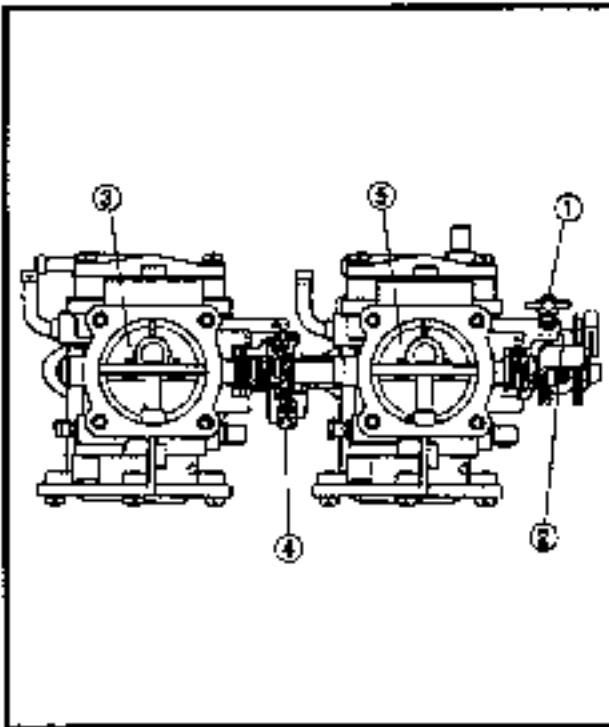
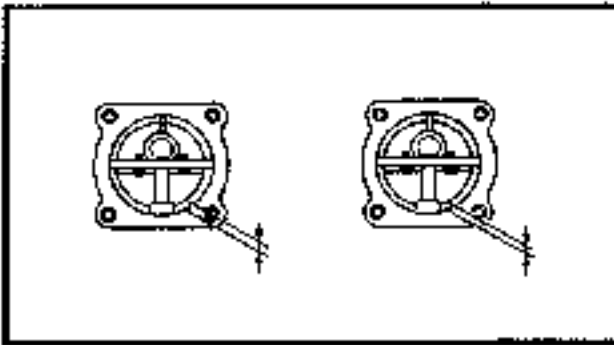
**SERVICE POINTS****Throttle valve synchronization inspection and adjustment****1. Check:**

- Throttle valve synchronization  
Out of specification → Adjust.

**Checking steps:**

- While turning the throttle lever, check the opening of all throttle valves.

**2. Adjust:**

- Throttle valve synchronization

**Adjustment steps: GP760**

- Turn out the idle adjust screws ① until their tips are apart from the throttle lever ②.

**NOTE:**

Record the set position of the idle adjust screw.

- Check that the #1 throttle valve ③ is fully closed.
- Turn the synchronization screw ④ in or out until the #2 throttle valve ⑤ is fully closed.
- Turn in the idle adjust screws to the set position.

**Adjustment steps: GP1200**

- Turn out the idle adjust screws ① until their tips are apart from the throttle lever ②.

**NOTE:**

Record the set position of the idle adjust screw.

- Loosen the screws ②.
- Tighten the screws ②.
- Turn in the idle adjust screws to the set position.

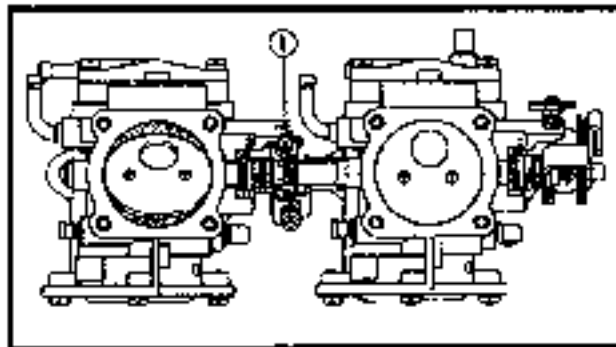
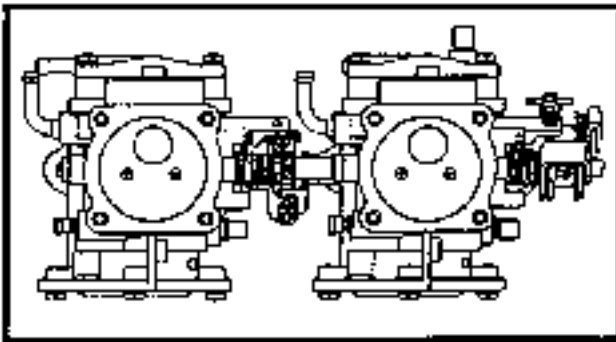

### Choke valve synchronization inspection and adjustment

#### 1. Check:

- Choke valve synchronization  
Out of specification → Adjust.

#### Checking steps:

- While turning the choke lever, check the opening of all choke valves.

#### 2. Adjust:

- Choke valve synchronization

#### Adjustment steps:

- Turn in or out the synchronization screw ① to bring all the choke valves into a fully closed position when the choke lever is turned on the closed side.

**CARBURETOR  
EXPLODED DIAGRAM**

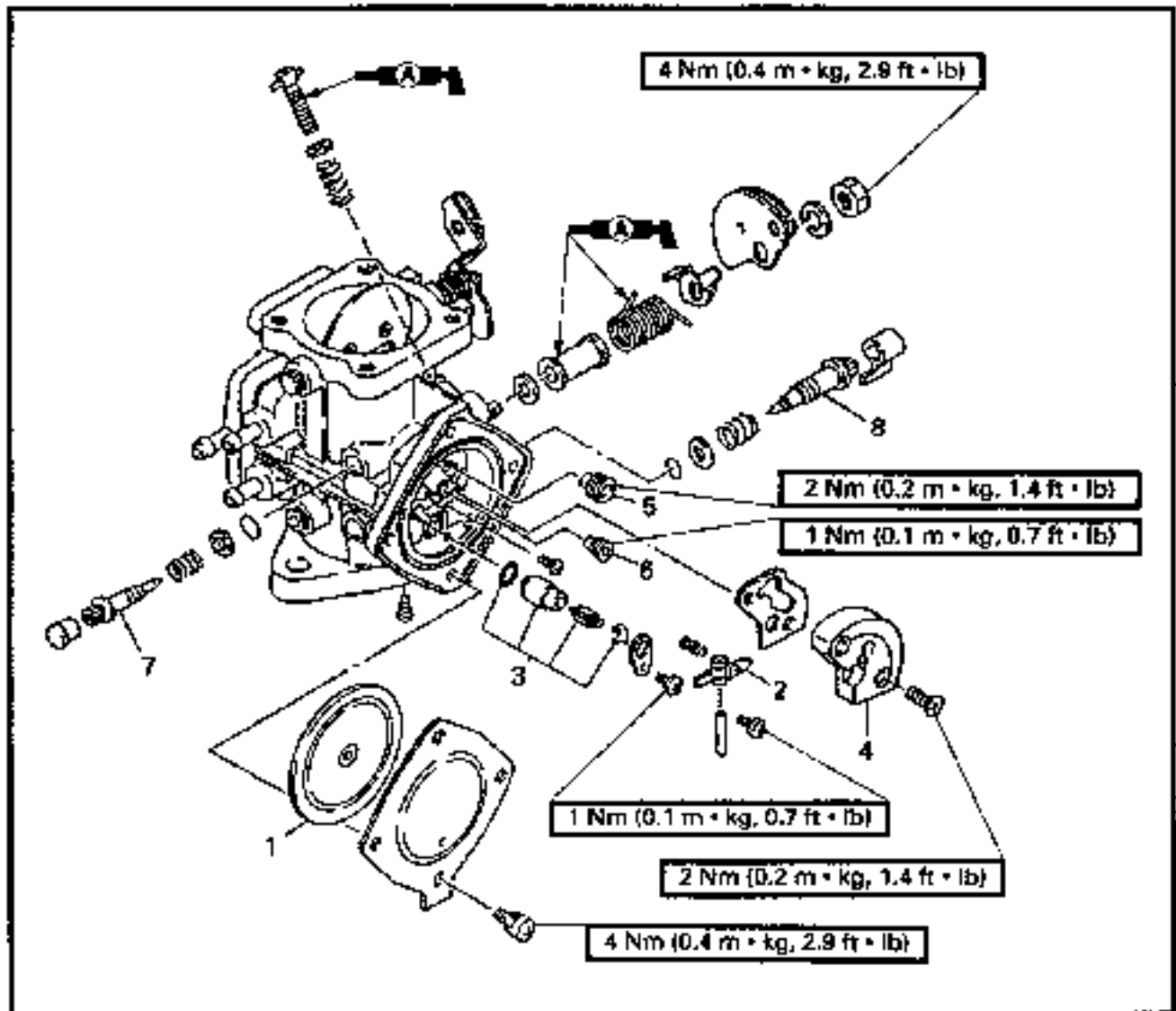

**REMOVAL AND INSTALLATION CHART**

Step	Procedure/Part name	Q'ty	Service points
	<b>CARBURETOR ASSEMBLY</b>		Follow the left "Step" for removal. Refer to "CARBURETOR REMOVAL".
1	Carburetor assembly		
1	Diaphragm assembly	1	
2	Float arm	1	
3	Needle valve assembly	1	
4	Body assembly	1	
5	Main jet	1	
6	Pilot jet	1	
7	High speed screw	1	
8	Low speed screw	1	
			Reverse the removal steps for installation.



## SERVICE POINTS

Do not use steel wire for cleaning the jets as this may enlarge the jet diameters and seriously affect performance.

### Diaphragm inspection

1. Inspect:
  - Diaphragm assembly
  - Damage → Replace.

### Float arm inspection

1. Inspect:
  - Float arm (1)
  - Bend/Damage → Repair or replace.
2. Measure:
  - Float arm height (2)

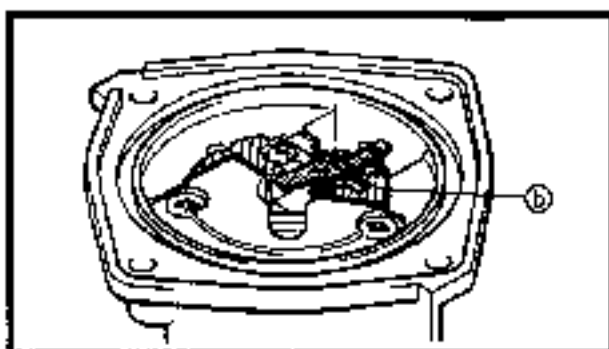
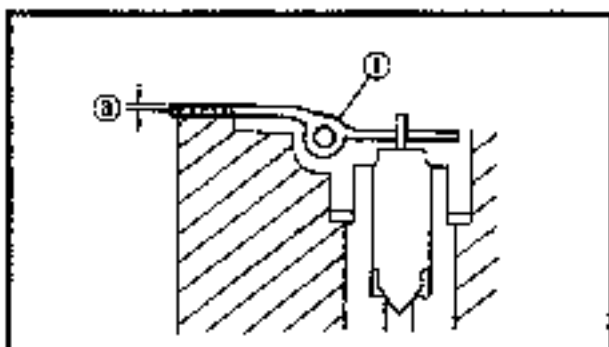

**Float arm height:**  
0 ~ 0.2 mm (0 ~ 0.008 in)

### NOTE:

- Measure the distance between the surface (2) of the carburetor body and the top surface of the float arm.
- The float arm should be resting on the needle valve, but not compressing the needle valve.

### Body assembly inspection

1. Inspect:
  - Body assembly (1)
  - Contamination → Clean.
  - Valve (2)
  - Damage → Replace.

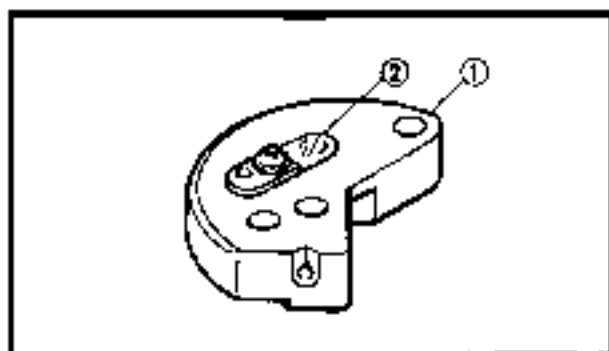

### Needle valve inspection

1. Inspect:
  - Needle valve
  - Valve seat
  - Grooved wear (3) → Replace.
  - Dust (4) → Clean.

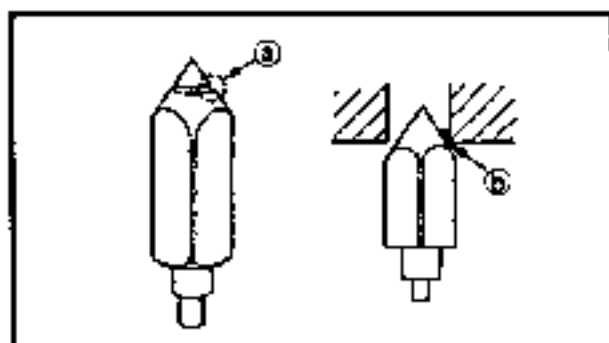

### NOTE:

Always replace the needle valve and valve seat as a set.





### Jet and carburetor body inspection

#### 1. Inspect:

- Main jet
  - Pilot jet
  - Carburetor body
- Contamination → Clean.

### High and low speed screws inspection

#### 1. Inspect:

- High speed screw
  - Low speed screw
- Band/Wear → Replace.

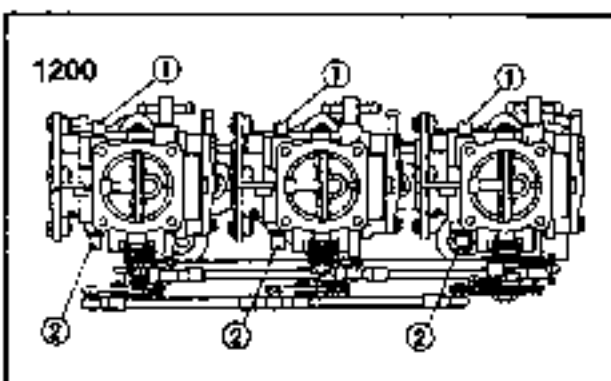
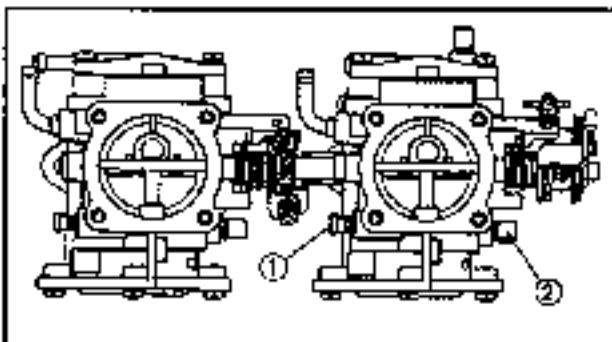

### High and low speed screws adjustment

#### 1. Adjust:

- High speed screw
- Low speed screw

#### Adjustment steps:

- Screw in the high speed screw (1) or lower speed screw (2) until it is lightly seated.
- Back out by the specified number of turns.



#### High speed screw:

##### GP760

$3/8 \pm 1/4$  turns out

##### GP1200

$1/2 \pm 1/4$  (#1, #3)

$7/8 \pm 1/4$  (#2) turns out

#### Low speed screw:

##### GP760

$1-5/8 \pm 1/4$  turns out

##### GP1200

$1-1/4 \pm 1/4$  (#1, #2)

$1-1/8 \pm 1/4$  (#3) turns out

### Carburetor assembly

#### 1. Adjust:

- Trailing speed
- Refer to "FUEL SYSTEM" in chapter 3.



**FUEL PUMP  
EXPLODED DIAGRAM**

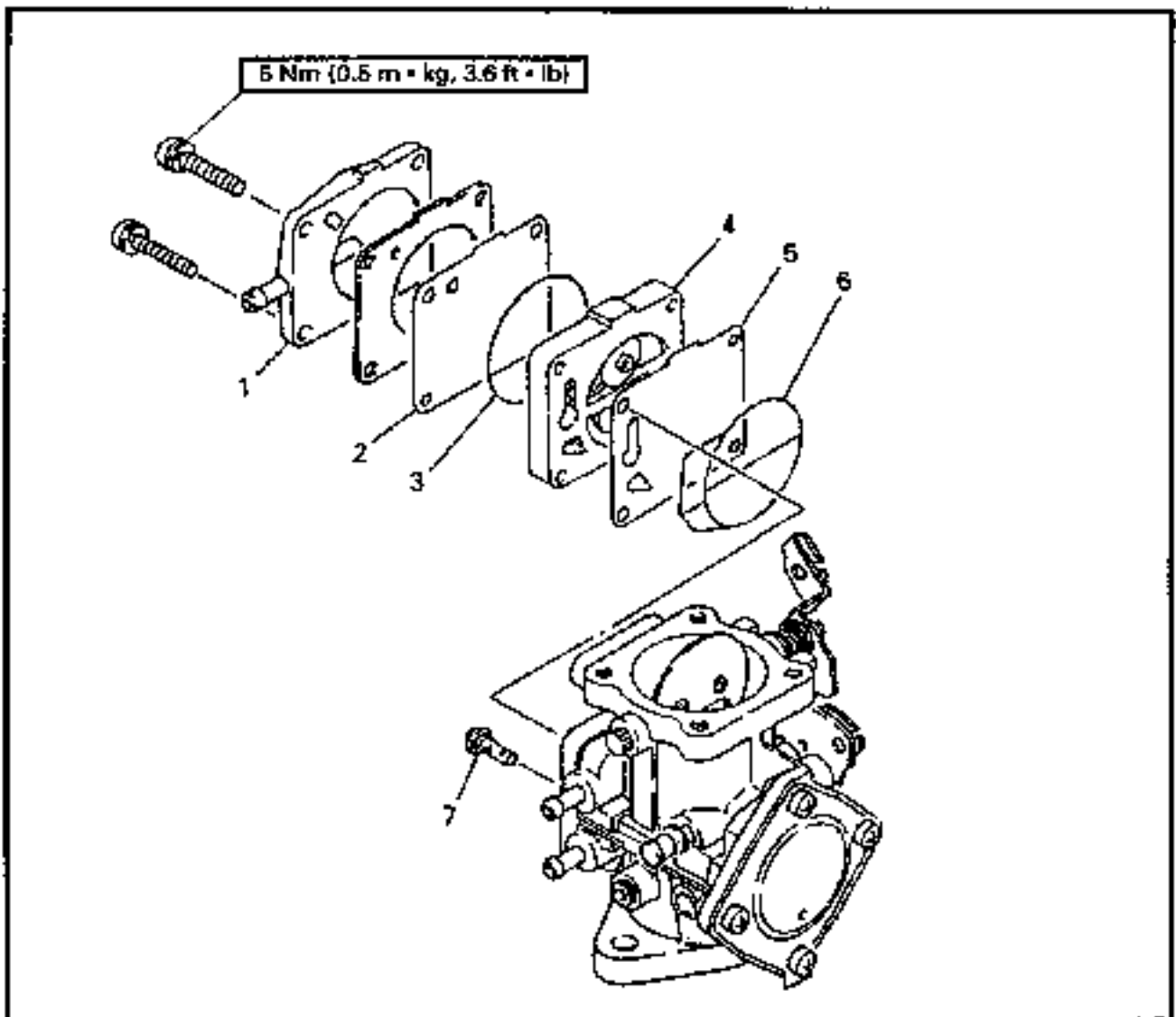

**REMOVAL AND INSTALLATION CHART**

Step	Procedure/Part name	Q'ty	Service points
	<b>FUEL PUMP DISASSEMBLY</b>		Follow the left "Step" for removal. Refer to "CARBURETOR REMOVAL".
1	Pump cover	1	
2	Diaphragm	1	
3	O-ring	1	
4	Diaphragm body assembly	1	
5	Diaphragm	1	
6	O-ring	1	
7	Filter	1	
			Reverse the removal steps for installation.



## FUEL PUMP

E

### SERVICE POINTS

#### Fuel pump inspection

1. Inspect:

- Diaphragm
  - Diaphragm body assembly
- Damage → Replace.

#### Filter inspection

1. Inspect:

- Filter
- Contamination → Clean.  
Damage → Replace.

**OIL LINE  
EXPLODED DIAGRAM**

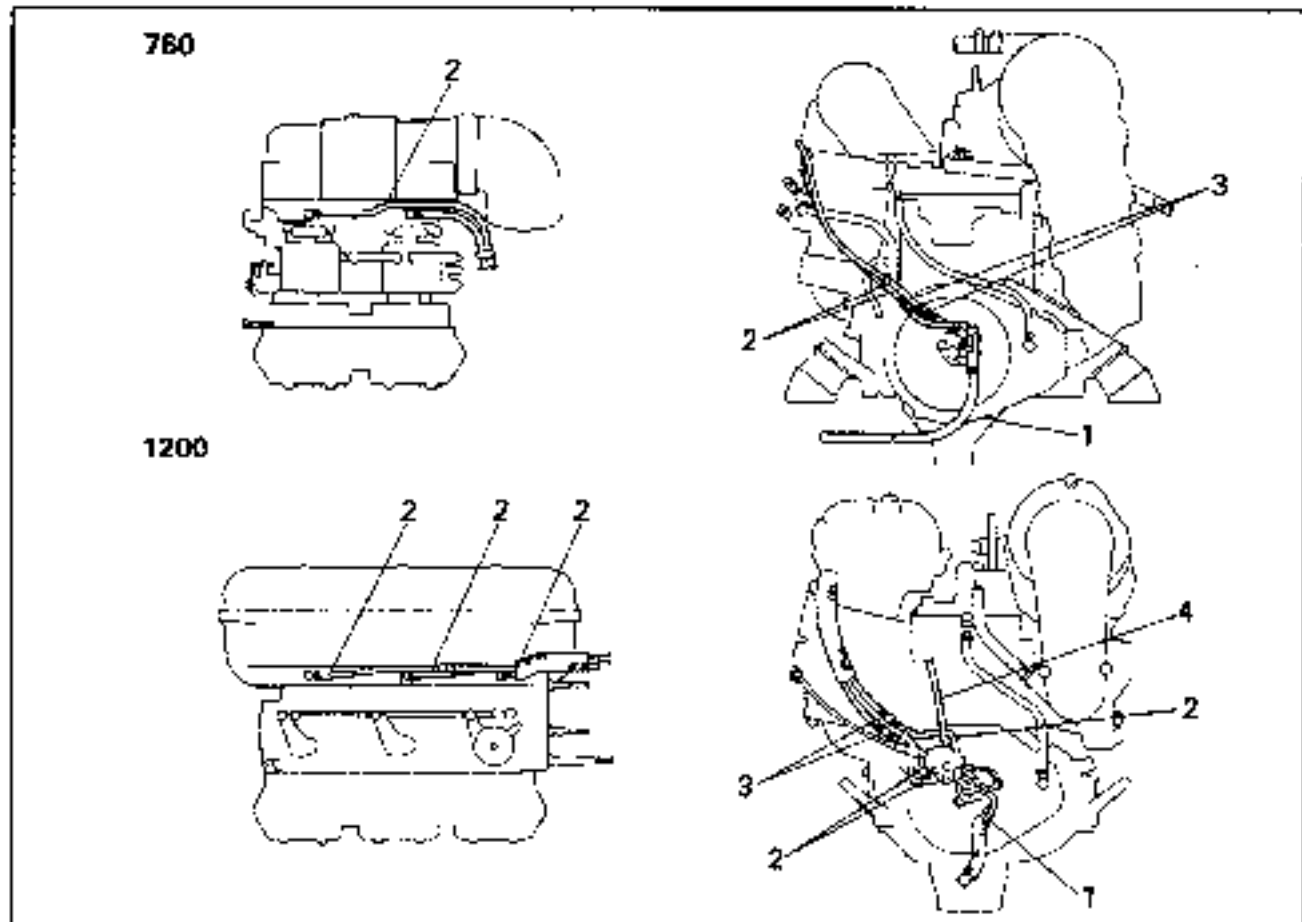

**REMOVAL AND INSTALLATION CHART**

Step	Procedure/Part name	Q'ty	Service points
	<b>OILPUMP DISASSEMBLY</b>	760, 1200	Follow the last "Step" for removal. Refer to "CARBURETOR UNIT REMOVAL".  Reverse the removal steps for installation.
	Carburetor cover 2		
1	Oil hose	1	
2	Derivaty hose	4, 6	
3	Check valve	2, 3	
4	Return hose	-, 1	

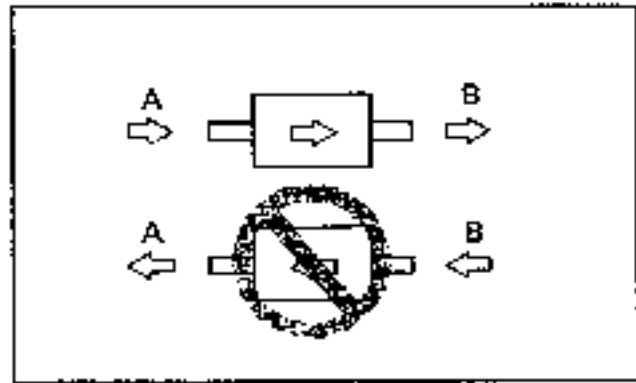

**SERVICE POINTS**

**Check valve inspection**

- Check:
  - Check valve
 Out of specification → Replace.





**OIL PUMP  
EXPLODED DIAGRAM**

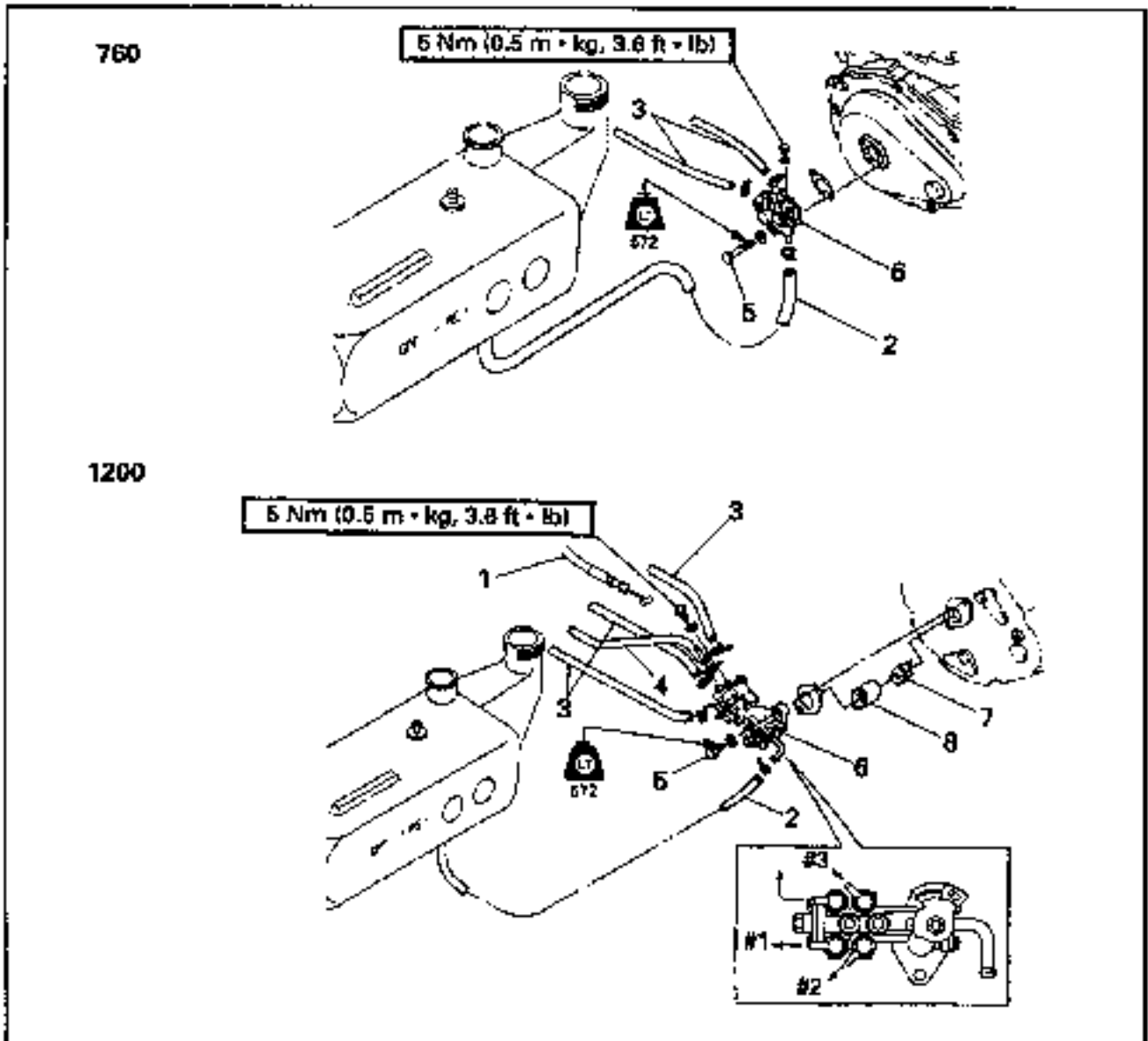

**REMOVAL AND INSTALLATION CHART**

Step	Procedure/Part name	Q'ty	Service points
	<b>OIL PUMP REMOVAL</b>	760 1200	Follow the left "Step" for removal.
1	Oil pump cable	- 1	
2	Oil hose	1	
3	Oil delivery hose	2, 3	
4	Oil return hose	- 1	
5	Bolt (with washer)	2	
6	Oil pump	1	
7	Joint	1	
8	Ring rubber	1	
			Reverse the removal steps for installation.

**SERVICE POINTS**

**Oil pump inspection**

1. Inspect:
  - Oil pump  
Clog → Clean.
  - Driving tooth  
Wear/Damage → Replace.

**Oil hose inspection**

1. Inspect:
  - Oil hose  
Wear/Crack → Replace.

- 
- If the delivery hoses are not full of oil, fill them up with oil.
  - After installing the oil injection system, bleed the system of air. Refer to "OIL INJECTION SYSTEM" in chapter 3.
- 

**Ring rubber inspection**

1. Inspect:
  - Ring rubber  
Wear/Damage → Replace.
  - Joint  
Wear/Damage → Replace.

**Ring rubber installation**

1. Install:
  - Ring rubber ①
  - Joint ②

**NOTE:** 

---

Install the joint into the joint rubber until the rubber stopper fits in the joint groove.  

---

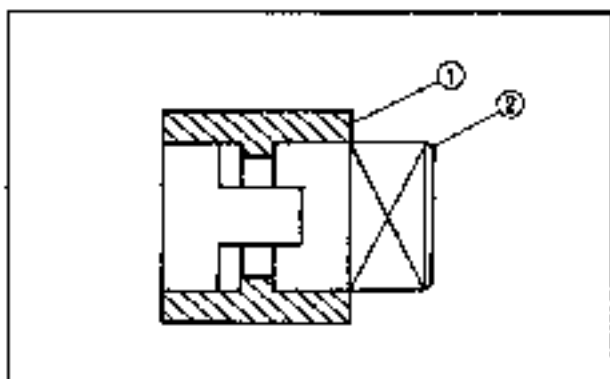



## CHAPTER 5 POWER UNIT

<b>ENGINE UNIT REMOVAL</b> .....	5 - 1
EXPLODED DIAGRAM (GP760) .....	5 - 1
REMOVAL AND INSTALLATION CHART .....	5 - 1
EXPLODED DIAGRAM (GP1200) .....	5 - 2
REMOVAL AND INSTALLATION CHART .....	5 - 2
SERVICE POINTS .....	5 - 3
Shim removal .....	5 - 3
Mount bracket inspection .....	5 - 3
Coupling clearance inspection .....	5 - 3
Pilot water hose installation .....	5 - 3
<b>REED VALVE</b> .....	5 - 4
EXPLODED DIAGRAM (GP760) .....	5 - 4
REMOVAL AND INSTALLATION CHART .....	5 - 4
EXPLODED DIAGRAM (GP1200) .....	5 - 5
REMOVAL AND INSTALLATION CHART .....	5 - 5
SERVICE POINTS .....	5 - 6
Reed valve inspection .....	5 - 6
<b>EXHAUST RING</b> .....	5 - 7
EXPLODED DIAGRAM (GP760) .....	5 - 7
REMOVAL AND INSTALLATION CHART .....	5 - 7
EXPLODED DIAGRAM (GP1200) .....	5 - 8
REMOVAL AND INSTALLATION CHART .....	5 - 8
<b>EXHAUST CHAMBER REMOVAL</b> .....	5 - 9
EXPLODED DIAGRAM (GP760) .....	5 - 9
REMOVAL AND INSTALLATION CHART .....	5 - 9
EXPLODED DIAGRAM (GP1200) .....	5 - 10
REMOVAL AND INSTALLATION CHART .....	5 - 10
<b>EXHAUST CHAMBER</b> .....	5 - 11
EXPLODED DIAGRAM (GP760) .....	5 - 11
REMOVAL AND INSTALLATION CHART .....	5 - 11
EXPLODED DIAGRAM (GP1200) .....	5 - 12
REMOVAL AND INSTALLATION CHART .....	5 - 12
<b>MUFFLER</b> .....	5 - 13
EXPLODED DIAGRAM (GP760) .....	5 - 13
REMOVAL AND INSTALLATION CHART .....	5 - 13
EXPLODED DIAGRAM (GP1200) .....	5 - 14
REMOVAL AND INSTALLATION CHART .....	5 - 14



<b>CYLINDER HEAD</b> .....	5 - 15
EXPLODED DIAGRAM (GP760) .....	5 - 15
REMOVAL AND INSTALLATION CHART .....	5 - 15
EXPLODED DIAGRAM (GP1200) .....	5 - 16
REMOVAL AND INSTALLATION CHART .....	5 - 16
SERVICE POINTS .....	5 - 17
Cylinder head inspection .....	5 - 17
<b>CYLINDER</b> .....	5 - 18
EXPLODED DIAGRAM (GP760) .....	5 - 18
REMOVAL AND INSTALLATION CHART .....	5 - 18
EXPLODED DIAGRAM (GP1200) .....	5 - 19
REMOVAL AND INSTALLATION CHART .....	5 - 19
SERVICE POINTS .....	5 - 20
Cylinder inspection .....	5 - 20
<b>PISTON</b> .....	5 - 21
EXPLODED DIAGRAM .....	5 - 21
REMOVAL AND INSTALLATION CHART .....	5 - 21
SERVICE POINTS .....	5 - 22
Piston pin clip removal and installation .....	5 - 22
Piston inspection .....	5 - 22
Piston ring inspection .....	5 - 23
Piston pin and bearing inspection .....	5 - 23
<b>FLYWHEEL MAGNETO AND BASE</b> .....	5 - 25
EXPLODED DIAGRAM (GP760) .....	5 - 25
REMOVAL AND INSTALLATION CHART .....	5 - 25
EXPLODED DIAGRAM (GP1200) .....	5 - 26
REMOVAL AND INSTALLATION CHART .....	5 - 26
SERVICE POINTS .....	5 - 27
Coupling flange removal and installation .....	5 - 27
Flywheel magneto removal and installation .....	5 - 27
Coupling flange inspection .....	5 - 27
Flywheel magneto inspection .....	5 - 27
Idle gear assembly inspection .....	5 - 28
<b>ELECTRICAL UNIT</b> .....	5 - 29
EXPLODED DIAGRAM (GP760) .....	5 - 29
REMOVAL AND INSTALLATION CHART .....	5 - 29
EXPLODED DIAGRAM (GP1200) .....	5 - 30
REMOVAL AND INSTALLATION CHART .....	5 - 30





<b>STARTER MOTOR</b> .....	5 - 31
EXPLODED DIAGRAM .....	5 - 31
REMOVAL AND INSTALLATION CHART .....	5 - 31
<b>SERVICE POINTS</b> .....	5 - 32
Pinion inspection .....	5 - 32
Armature inspection .....	5 - 32
Brush holder inspection .....	5 - 33
Cover inspection .....	5 - 33
 <b>CRANKCASE</b> .....	5 - 34
EXPLODED DIAGRAM (GP780) .....	5 - 34
REMOVAL AND INSTALLATION CHART .....	5 - 34
EXPLODED DIAGRAM (GP1200) .....	5 - 35
REMOVAL AND INSTALLATION CHART .....	5 - 35
<b>SERVICE POINTS</b> .....	5 - 36
Crankcase inspection .....	5 - 36
Crankcase installation .....	5 - 36
 <b>CRANKSHAFT</b> .....	5 - 37
EXPLODED DIAGRAM (GP760) .....	5 - 37
REMOVAL AND INSTALLATION CHART .....	5 - 37
EXPLODED DIAGRAM (GP1200) .....	5 - 38
REMOVAL AND INSTALLATION CHART .....	5 - 38
<b>SERVICE POINTS</b> .....	5 - 39
Crankshaft inspection .....	5 - 39
 <b>INTERMEDIATE HOUSING REMOVAL</b> .....	5 - 41
EXPLODED DIAGRAM .....	5 - 41
REMOVAL AND INSTALLATION CHART .....	5 - 41
 <b>INTERMEDIATE HOUSING</b> .....	5 - 42
EXPLODED DIAGRAM .....	5 - 42
REMOVAL AND INSTALLATION CHART .....	5 - 42
<b>SERVICE POINTS</b> .....	5 - 43
Coupling removal and installation .....	5 - 43
Bearing removal and installation .....	5 - 43
Bearing inspection .....	5 - 43
Coupling inspection .....	5 - 43
Oil seal installation .....	5 - 44



**ENGINE UNIT REMOVAL**  
**EXPLODED DIAGRAM (GP760)**

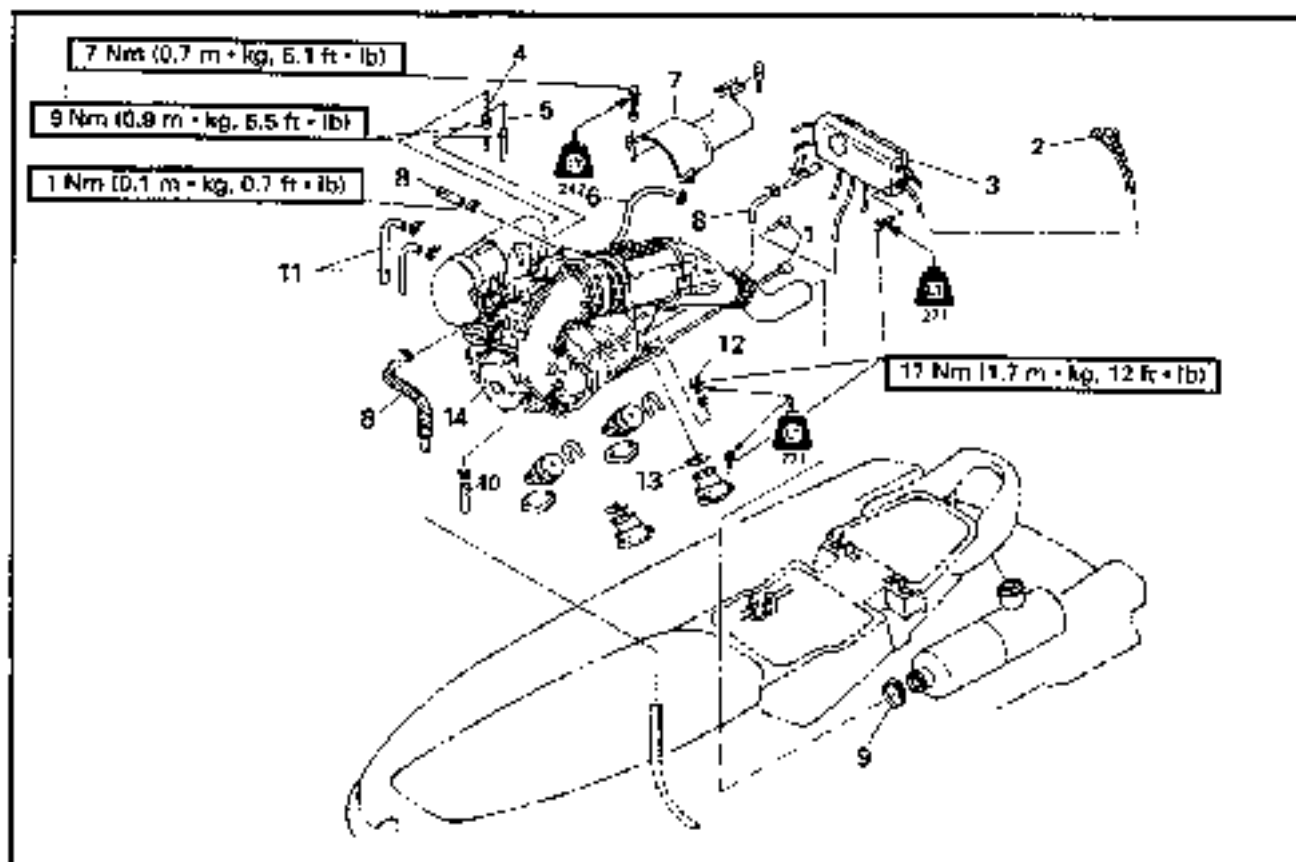

**REMOVAL AND INSTALLATION CHART**

Step	Procedure/Part name	Qty	Service points
	<b>ENGINE UNIT REMOVAL</b>		Follow the left "Step" for removal.
	Trim control cable 1, 2	2	
1	Battery lead	2	
2	Lead coupler	3	
3	Electrical box	1	
4	Choke cable	1	
5	Throttle cable	1	
6	Grease hose	1	
7	Coupling cover	1	
8	Water hose	3	
9	Exhaust hose clamp	1	
10	Oil hose	1	
11	Fuel hose	2	
12	Engine mounting bolt	4	
13	Shim	-	
14	Engine unit	1	
			Reverse the removal steps for installation.

\* As required



EXPLODED DIAGRAM (GP1200)

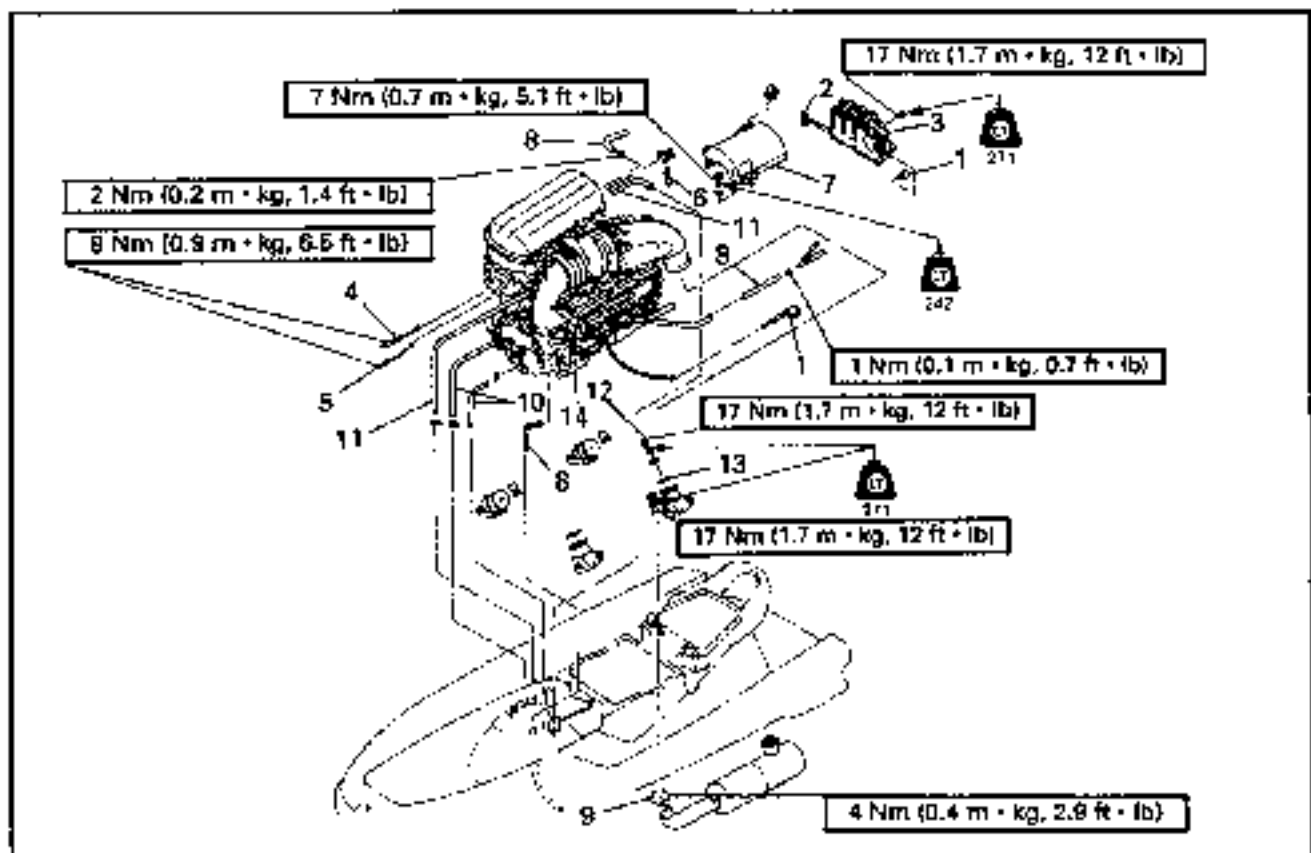

REMOVAL AND INSTALLATION CHART

Step	Procedure/Part name	Q'ty	Service points
	<b>ENGINE UNIT REMOVAL</b>		Follow the left "Step" for removal.
	Trim control cable 1, 2	2	
1	Battery lead	2	
2	Lead coupler	3	
3	Electrical box	1	
4	Choke cable	1	
5	Throttle cable	1	
6	Grease hose	1	
7	Coupling cover	1	
8	Water hose	3	
9	Exhaust hose clamp	1	
10	Oil hose	2	
11	Fuel hose	2	
12	Engine mounting bolt	4	
13	Shim	-	
14	Engine unit	1	
			Reverse the removal steps for installation.

\*: As required



**SERVICE POINTS**

**Shim removal**

1. Remove:
  - Shim

**NOTE:**

Make the engine mounting shim packs prior to the mounting bolt removal for ease of reassembly and coupling alignment.

**Mount bracket inspection**

1. Inspect:
  - Mount bracket
  - Crack/Damage → Replace.

**Coupling clearance inspection**

1. Measure:
  - Clearance ③
  - Clearance ④
  - Out of specification → Adjust using shim.

**NOTE:**

- Before measuring the clearance, remove the coupling rubber.
- Attach a straight edge and a thickness gauge.

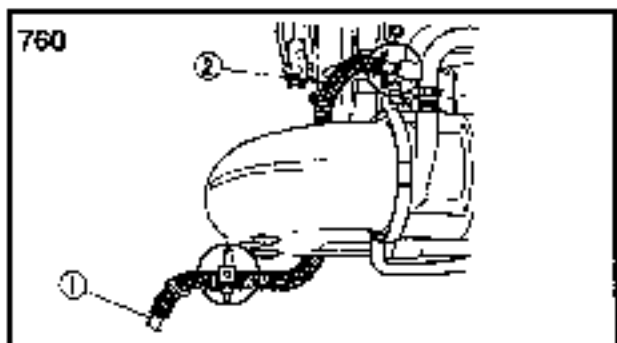
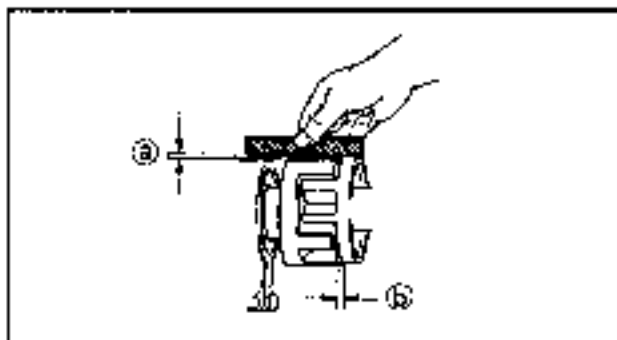

	Clearance ③:
	0 ~ 1.0 mm (0 ~ 0.039 in)
	Clearance ④:
	2 ~ 4 mm (0.079 ~ 0.157 in)

**Pilot water hose installation**

1. Install:
  - Pilot water hose ①

**NOTE:**

**GP760**

- Clamp the water pilot hose with its cover tube ② contacting the cylinder head.

**GP1200**

- Clamp the electrical box leads, speed sensor lead, water pilot hose and air ventilation hose with the band.

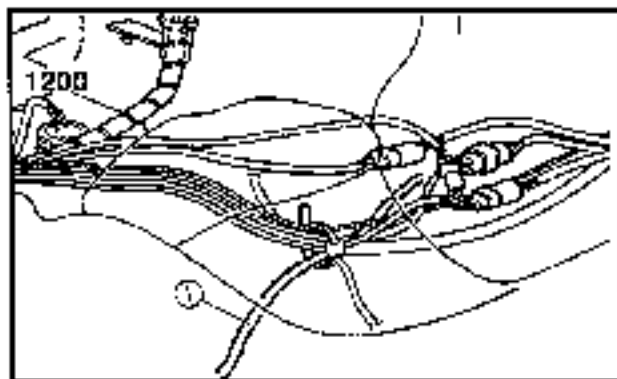



**REED VALVE**

**EXPLODED DIAGRAM (GP760)**

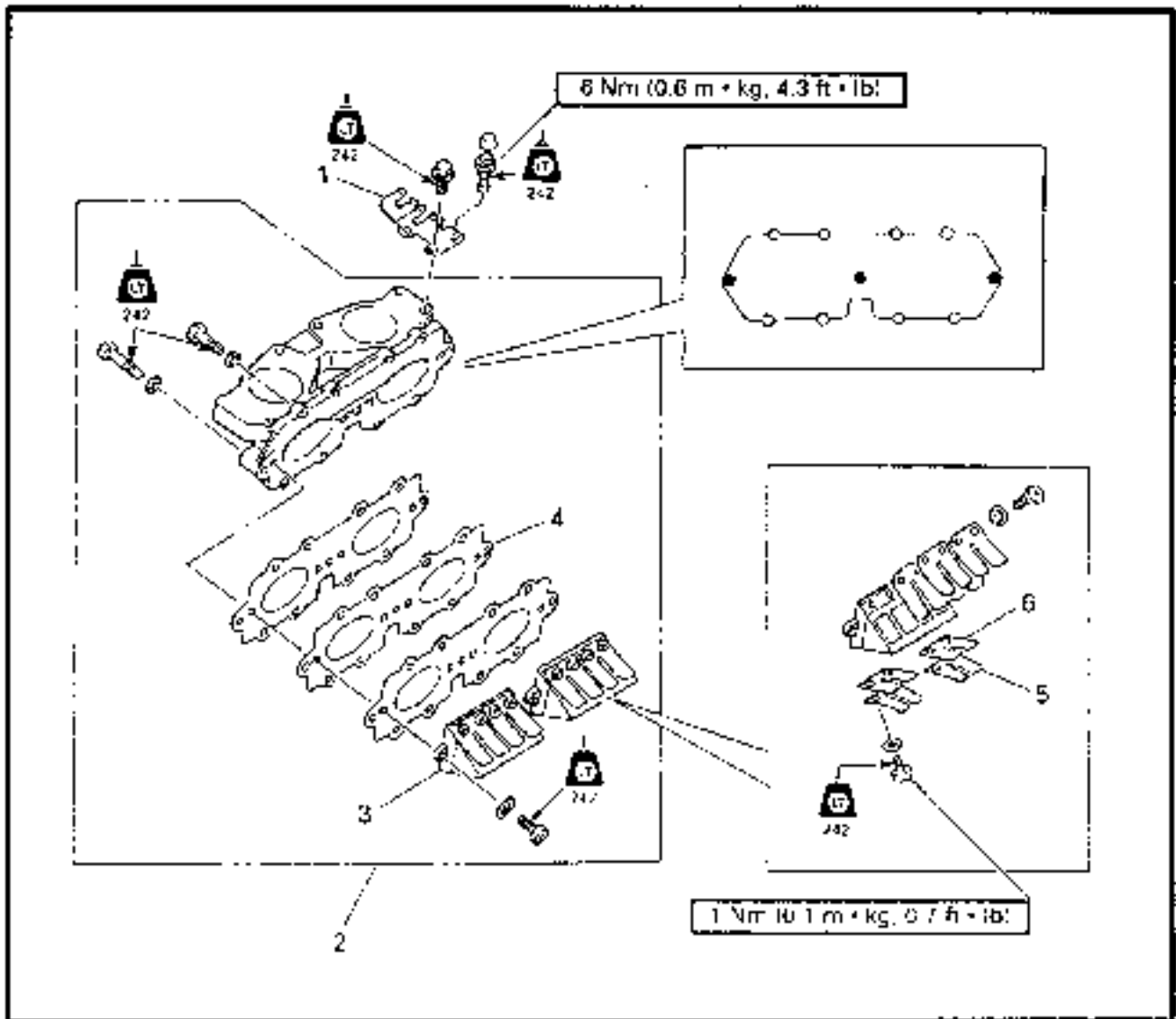

**REMOVAL AND INSTALLATION CHART**

Step	Procedure/Part name	Q'ty	Service points
	<b>REED VALVE REMOVAL</b>		Follow the left "Step" for removal. Refer to "CARBURETOR REMOVAL" in chapter 4.  Reverse the removal steps for installation.
	Carburetor assembly		
1	Plate	1	
2	Intake manifold assembly	1	
3	Reed valve assembly	2	
4	Plate	1	
5	Valve stopper	4	
6	Reed valve	4	



EXPLODED DIAGRAM (GP1200)

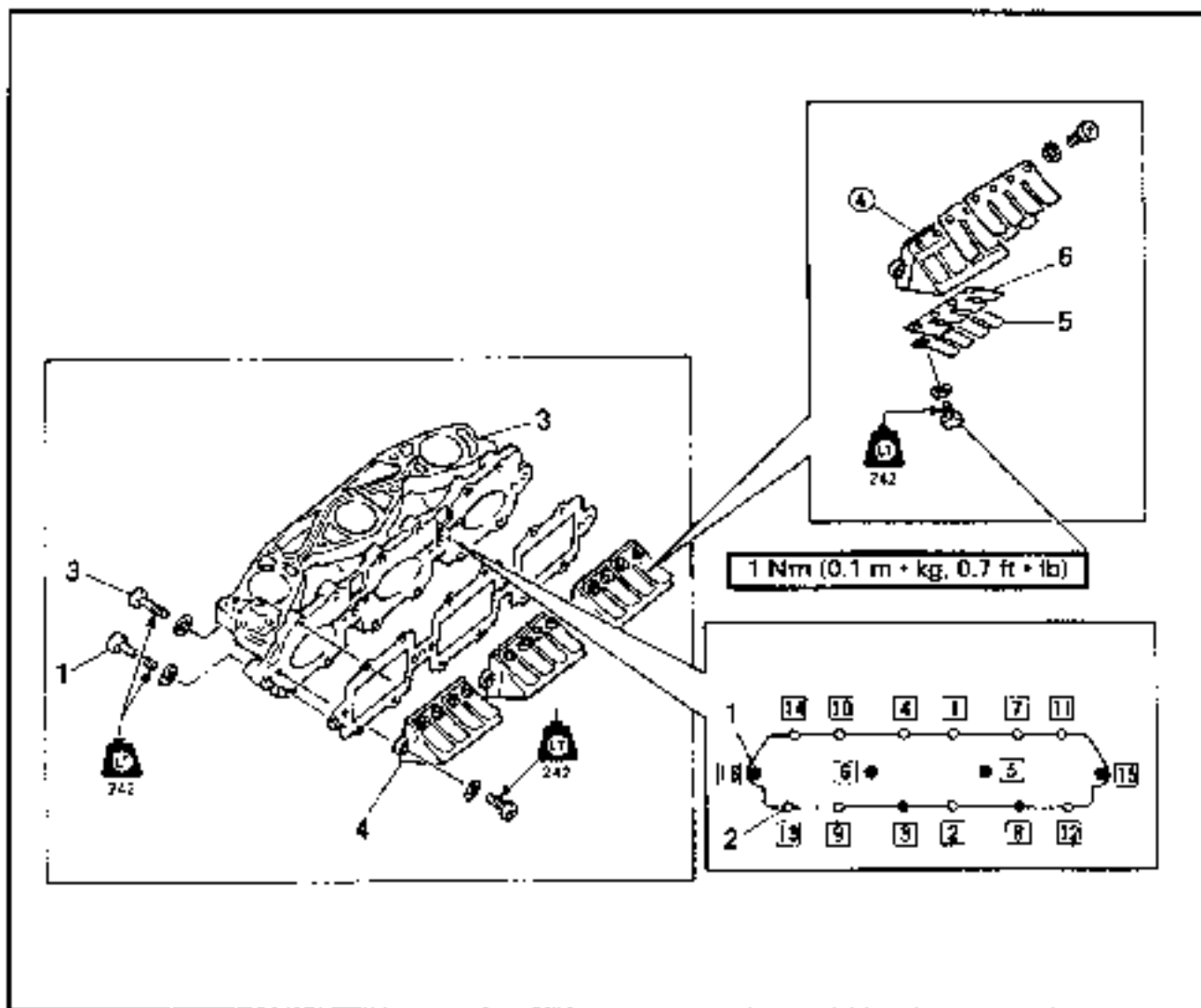

REMOVAL AND INSTALLATION CHART

Step	Procedure/Part name	Q'ty	Service points
<b>REED VALVE REMOVAL</b>			Follow the left "Step" for removal. Refer to "CARBURETOR REMOVAL" in chapter 4.  <b>NOTE:</b> _____ Tighten the bolts in sequence. _____ Reverse the removal steps for installation.
Carburetor assembly			
1	Bolt (with washer)	6	
2	Bolt (with washer)	10	
3	Intake manifold assembly	1	
4	Reed valve assembly	3	
5	Valve stopper	6	
6	Reed valve	6	

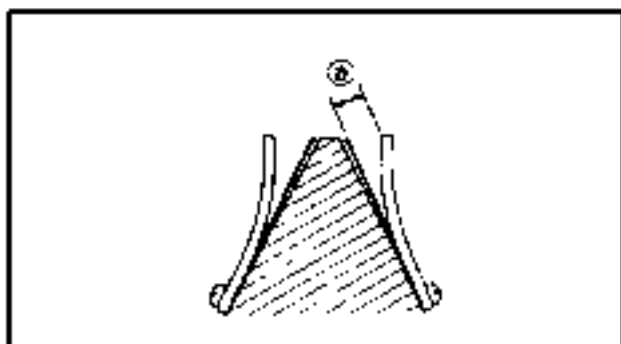
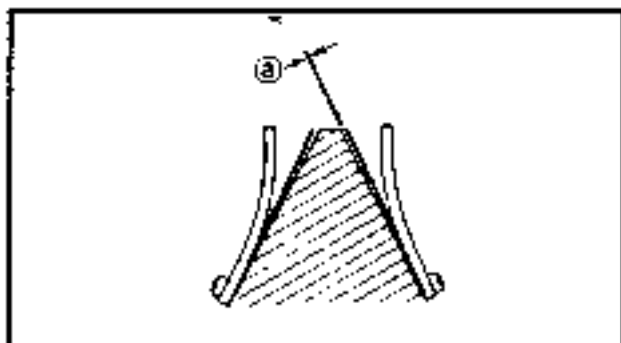

## SERVICE POINTS

### Reed valve inspection

1. Inspect:
  - Reed valve  
Crack/Damage → Replace.
2. Measure:
  - Valve bending (a)  
Out of specification → Replace.



**Valve bending limit:**  
0.2 mm (0.01 in)

3. Measure:
  - Valve stopper height (a)  
Out of specification → Adjust or replace.



**Valve stopper height:**  
**GP 760:**  
 $9.0 \pm 0.2$  mm ( $0.35 \pm 0.01$  in)  
**GP 1200:**  
 $12.5 \pm 0.2$  mm ( $0.49 \pm 0.01$  in)



**EXHAUST RING  
EXPLODED DIAGRAM (GP760)**

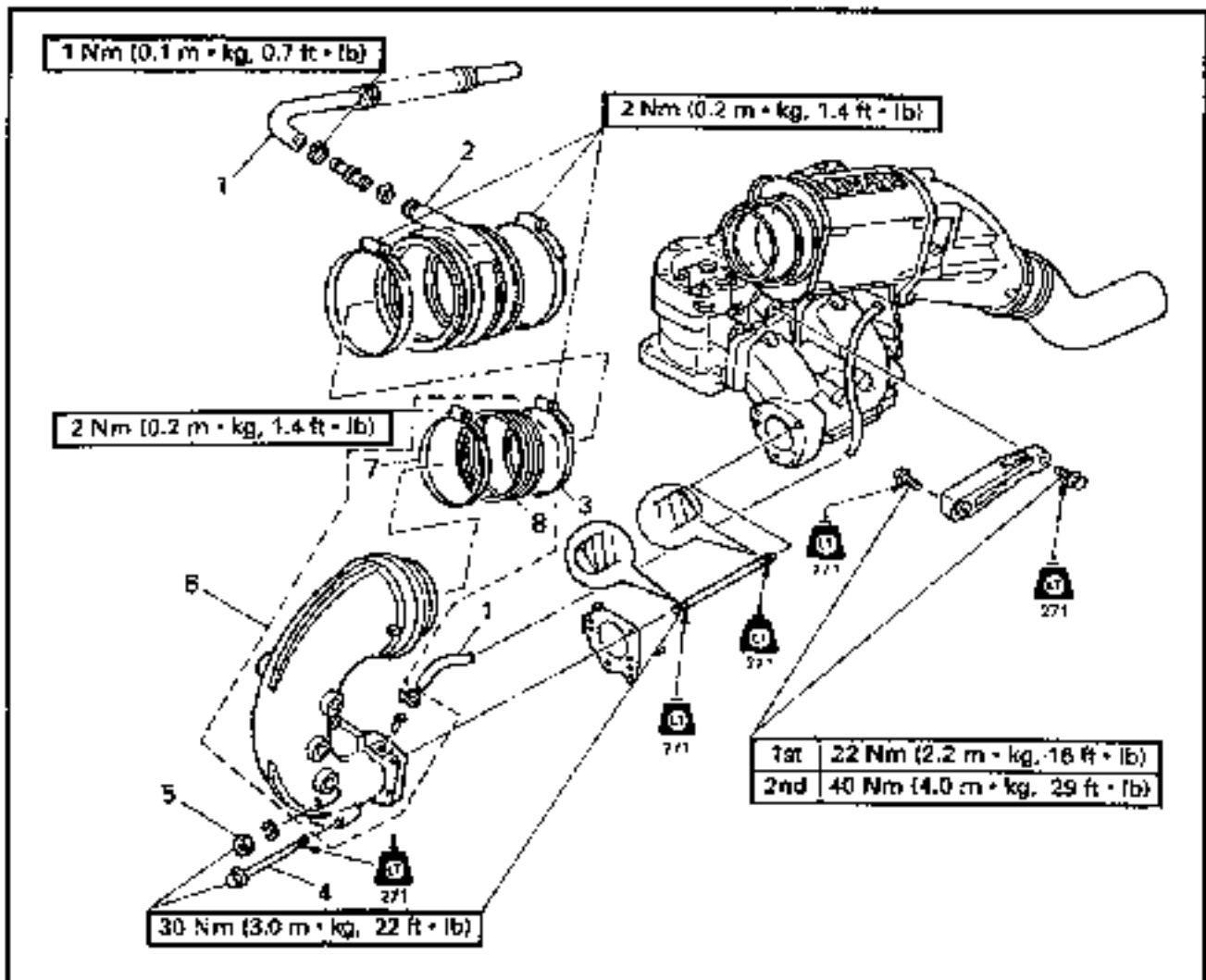

**REMOVAL AND INSTALLATION CHART**

Step	Procedure/Part name	Q'ty	Service points
	<b>EXHAUST RING REMOVAL</b>		
	Engine unit		Follow the left "Step" for removal. Refer to "ENGINE UNIT REMOVAL".
1	Water hose	2	
2	Exhaust joint	1	<b>NOTE:</b> _____
3	Clamp	1	● Loosen the clamp at the muffler side.
4	Bolt (with washer)	2	● Pull and slide the exhaust joint.
5	Nut	2	
6	Ring	1	<b>NOTE:</b> _____
7	Clamp	1	Tighten the clamp before installing the ring on the muffler.
8	Joint	1	
			Reverse the removal steps for installation.





EXPLODED DIAGRAM (GP1200)

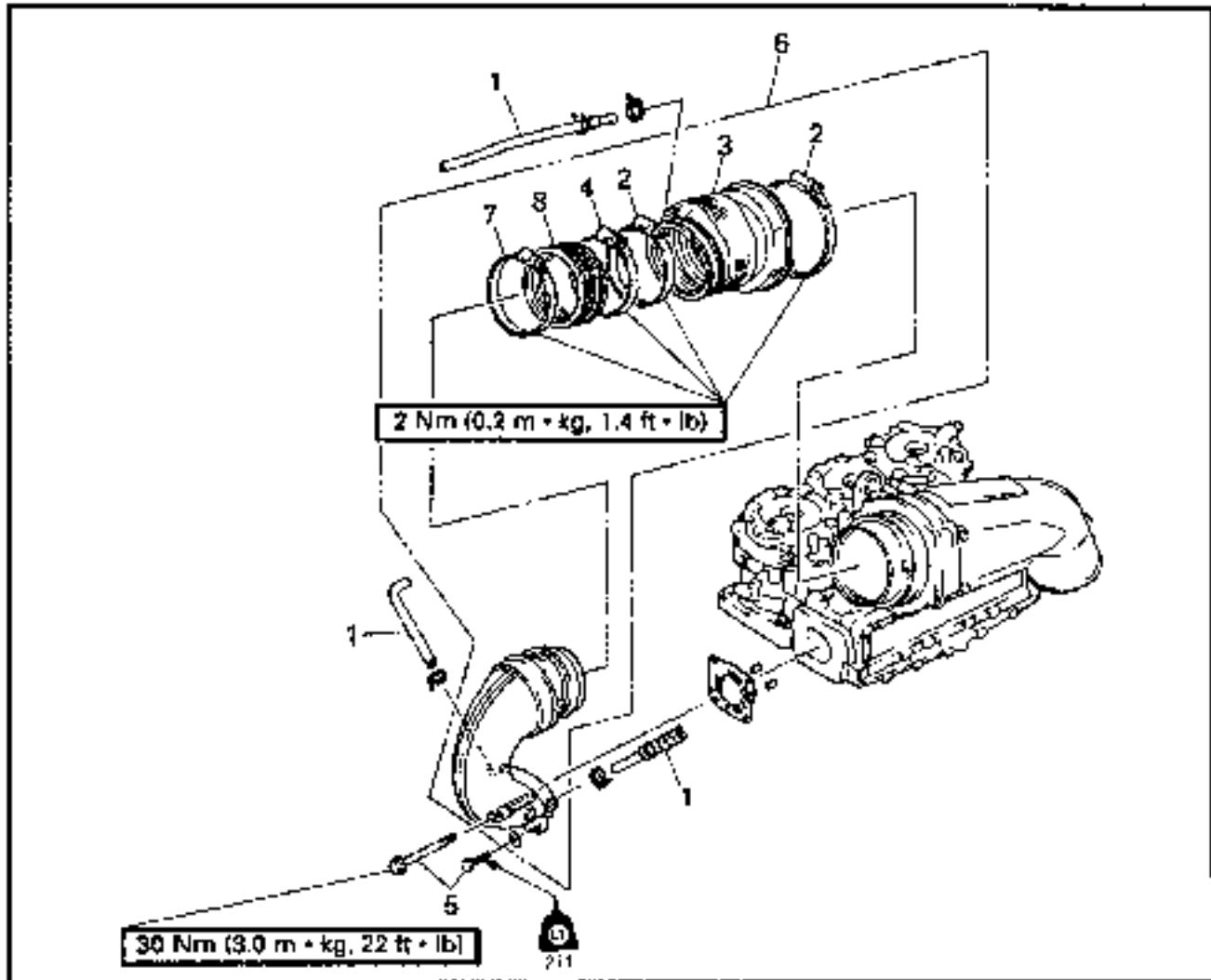

REMOVAL AND INSTALLATION CHART

Step	Procedure/Part name	Q'ty	Service points
	<b>EXHAUST RING REMOVAL</b>		
	Engine unit		Follow the left "Step" for removal. Refer to "ENGINE UNIT REMOVAL".
1	Water hose	3	
2	Exhaust joint	2	<b>NOTE:</b> _____
3	Clamp	1	• Loosen the clamp at the muffler side.
4	Bolt (with washer)	1	• Pull and slide the exhaust joint.
5	Nut	4	_____
6	Ring	1	<b>NOTE:</b> _____
7	Clamp	1	Tighten the clamp, before installing the ring on the muffler.
8	Joint	1	_____
			Reverse the removal steps for installation.



**EXHAUST CHAMBER REMOVAL  
EXPLODED DIAGRAM (GP760)**

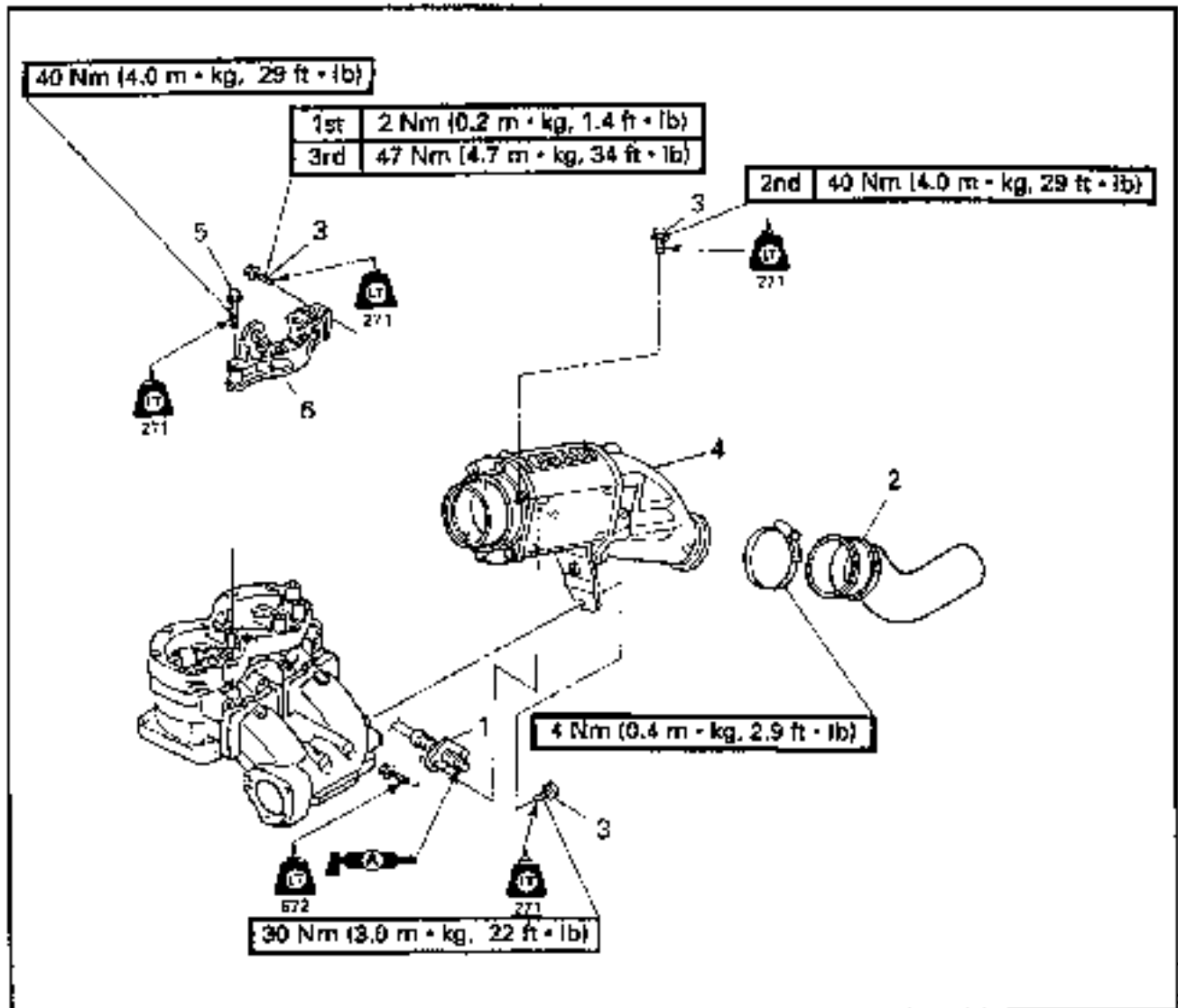

**REMOVAL AND INSTALLATION CHART**

Step	Procedure/Part name	Q'ty	Service points
	<b>EXHAUST CHAMBER REMOVAL</b>		
	Ring		Follow the left "Step" for removal. Refer to "EXHAUST RING".
1	Thermo switch	1	
2	Exhaust hose	1	
3	Bolt (muffler)	5	<b>NOTE:</b> _____
4	Exhaust chamber assembly	1	Tighten the bolts in sequence.
5	Bolt (muffler stay)	4	_____
6	Muffler stay	1	
			Reverse the remove steps for installation.



**EXPLODED DIAGRAM (GP1200)**

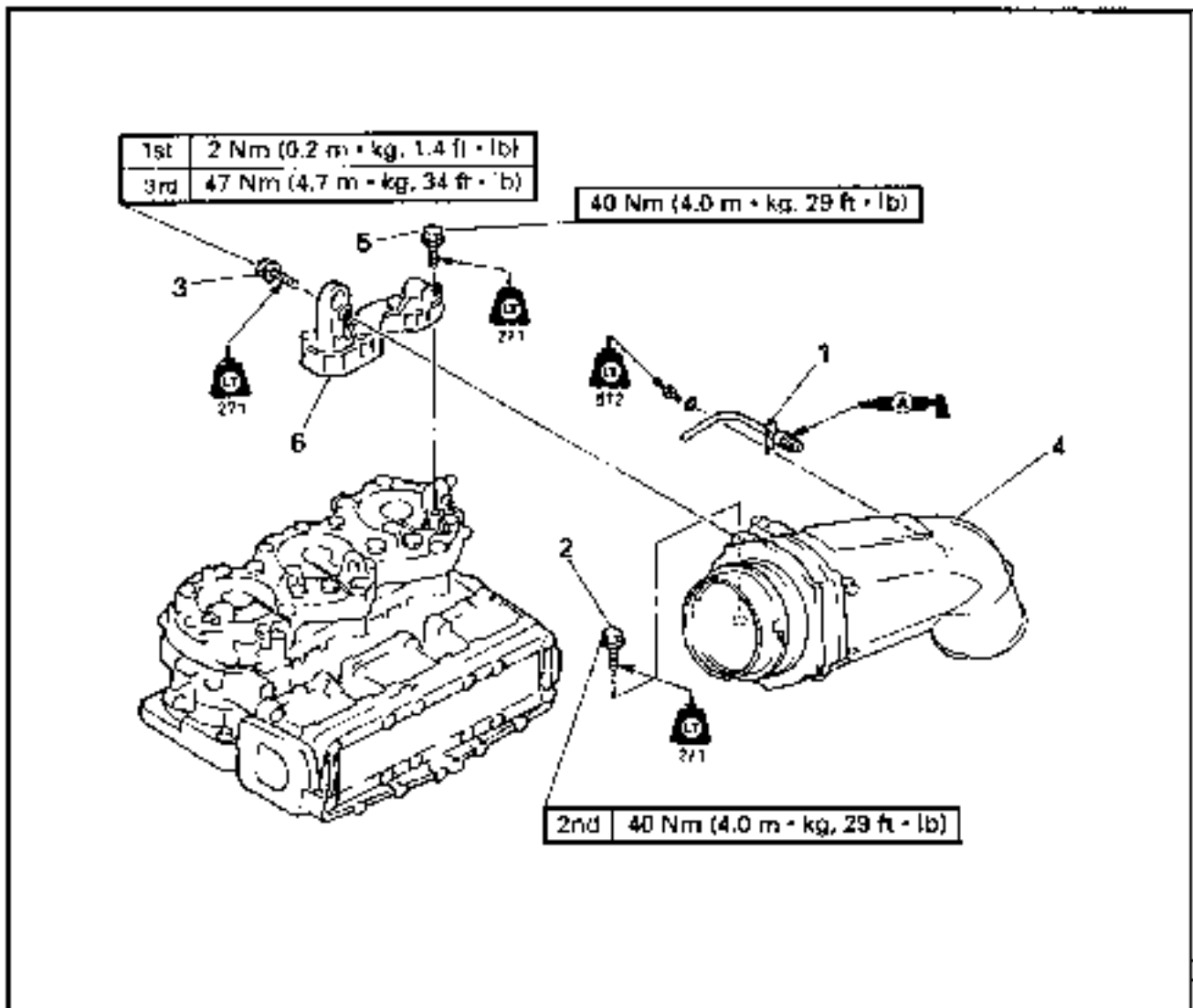

**REMOVAL AND INSTALLATION CHART**

Step	Procedure/Part name	Q'ty	Service points
	<b>EXHAUST CHAMBER REMOVAL</b>		Follow the left "Step" for removal Refer to "EXHAUST RING".
1	Thermo switch	1	
2	Bolt (with washer)	2	M8 x 35mm ● 12
3	Bolt (with washer)	2	M8 x 35mm ● 14
4	Exhaust chamber assembly	1	<b>NOTE:</b> _____ Tighten the bolts sequence. _____
5	Bolt (muller stay)	4	M10 x 45mm
6	Muller stay	1	
			Reverse the removal steps for installation.



**EXHAUST CHAMBER**  
**EXPLODED DIAGRAM (GP760)**

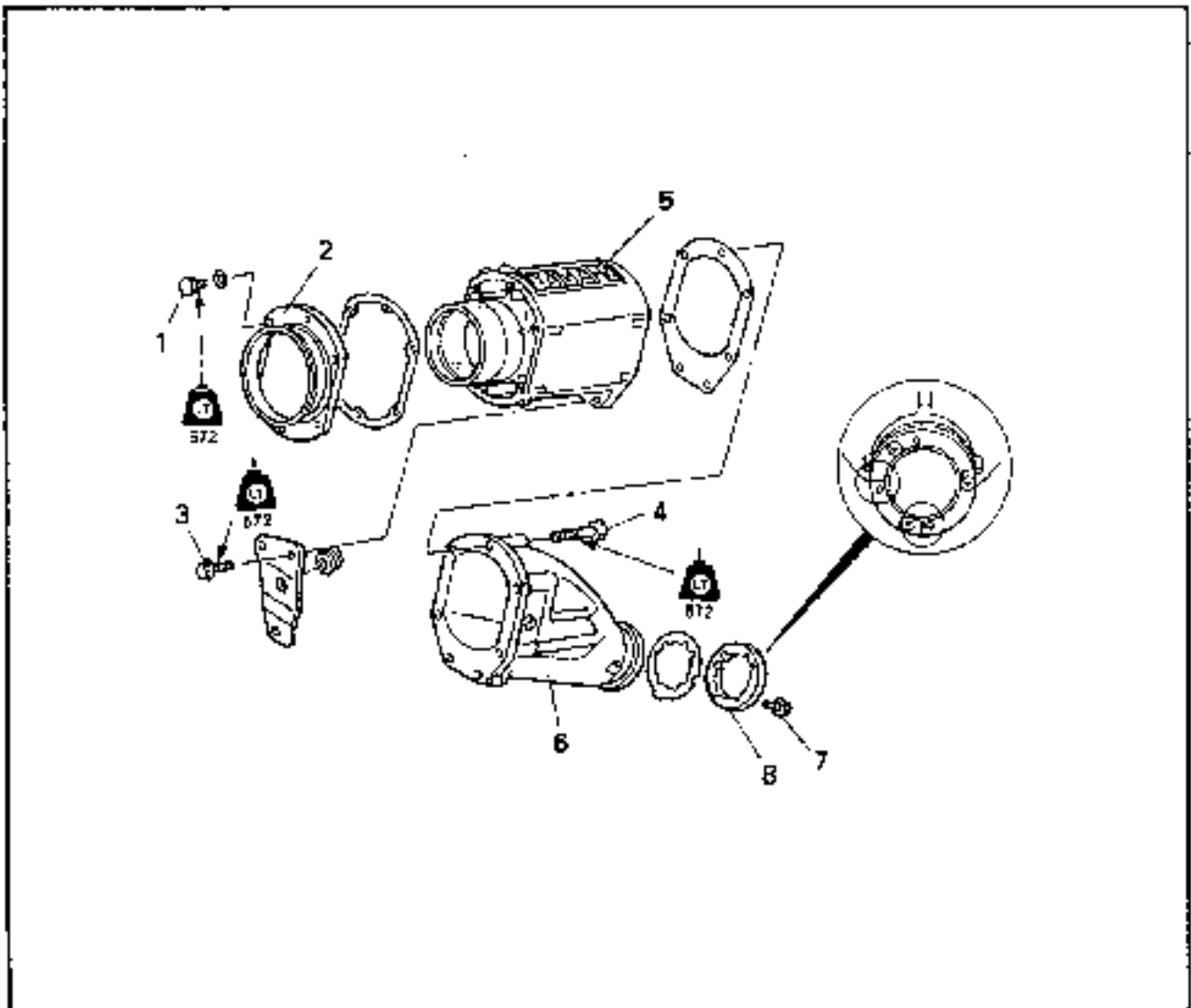

**REMOVAL AND INSTALLATION CHART**

Step	Procedure/Part name	Q'ty	Service points
	<b>CHAMBER DISASSEMBLY</b>		
	Exhaust chamber assembly		Follow the left "Step" for removal. Refer to "EXHAUST CHAMBER REMOVAL."
1	Bolt (with washer)	6	
2	Exhaust cover 1	1	
3	Bolt (with washer)	2	
4	Bolt (with washer)	7	
5	Exhaust cover 2	1	
6	Muffler	1	
7	Screw	3	
8	Seal	1	
			Reverse the removal steps for installation.



EXPLODED DIAGRAM (GP1200)

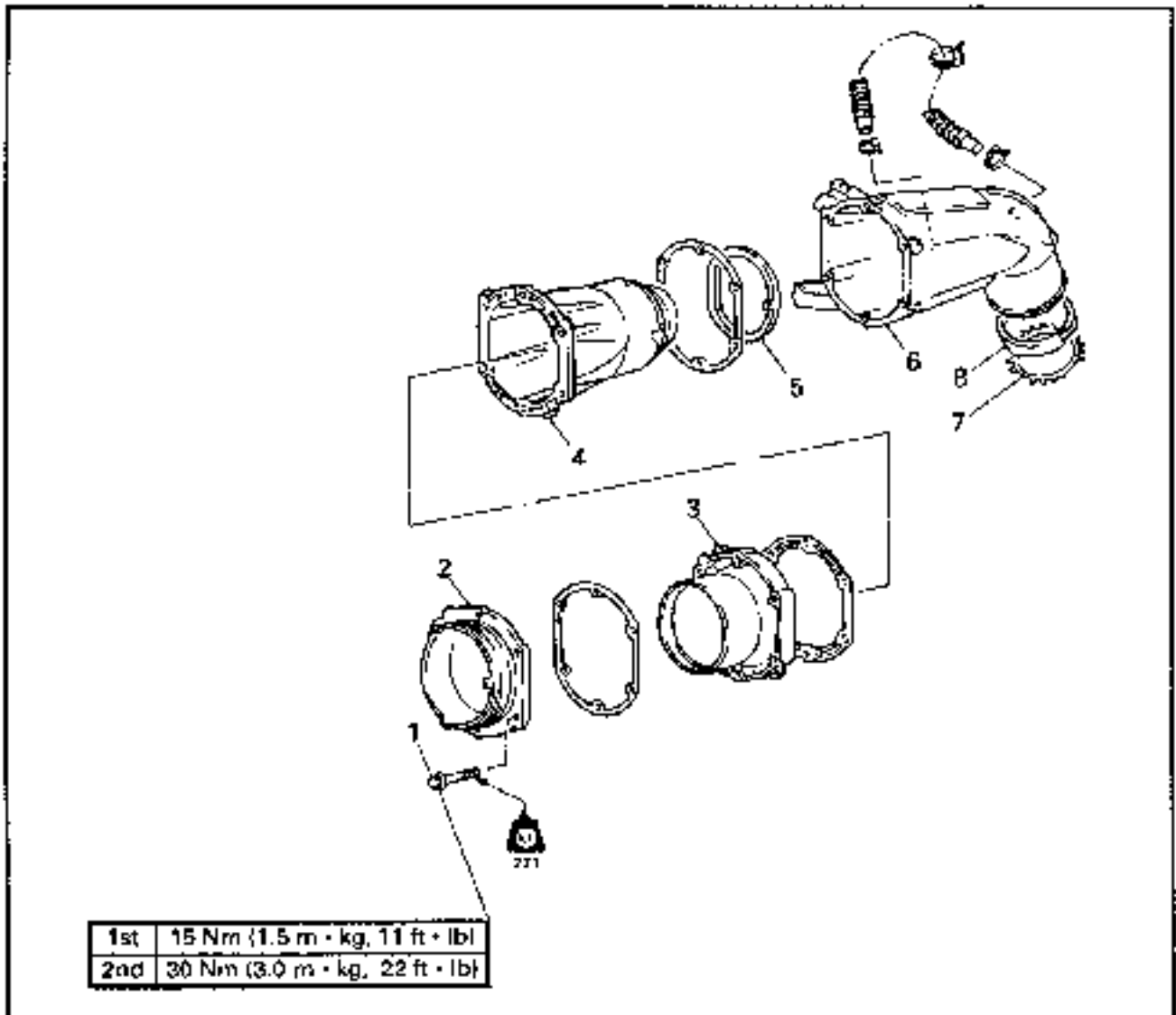

REMOVAL AND INSTALLATION CHART

Step	Procedure/Part name	Q'ty	Service points
	<b>CHAMBER DISASSEMBLY</b>		
	Exhaust chamber assembly		Follow the left *Step* for removal.
			Refer to *EXHAUST CHAMBER REMOVAL*.
1	Bolt (with washer)	6	M8 x 60 mm
2	Exhaust outer cover 1	1	<b>NOTE:</b> _____
3	Muffler 2	1	Tighten the bolts in sequence.
4	Exhaust inner cover	1	
5	Seal	1	
6	Exhaust outer cover 2	1	
7	Stopper	1	
8	Seal	1	
			Reverse the removal steps for installation.



MUFFLER

EXPLODED DIAGRAM (GP760)

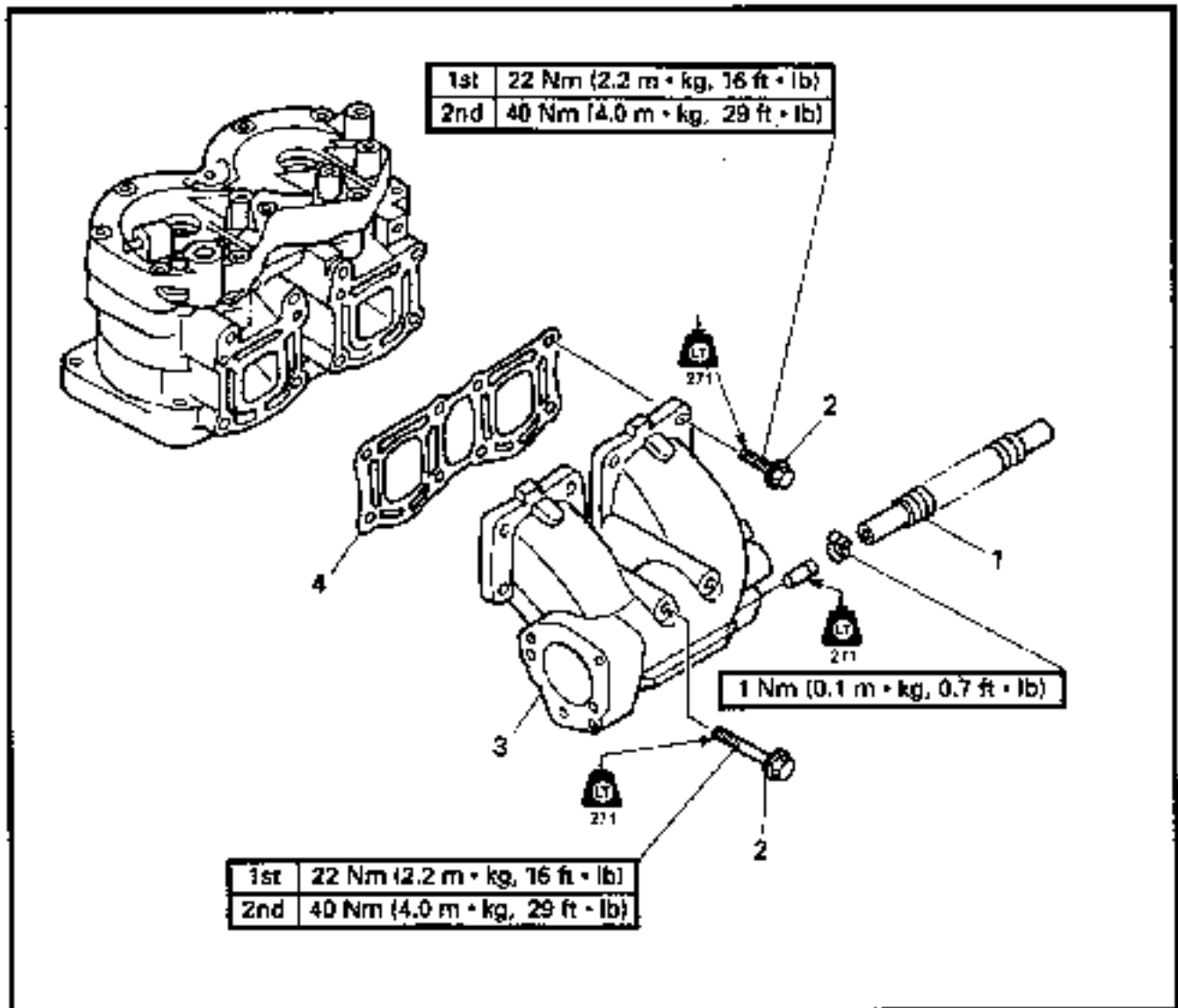

REMOVAL AND INSTALLATION CHART

Step	Procedure/Part name	Q'ty	Service points
	<b>MUFFLER REMOVAL</b>		
	Exhaust chamber assembly		Follow the left "Step" for removal. Refer to "EXHAUST CHAMBER REMOVAL".
1	Water inlet hose	1	
2	Bolt (with washer)	8	
3	Muffler	1	
4	Gasket	1	
			Reverse the removal steps for installation.



EXPLODED DIAGRAM (GP1200)

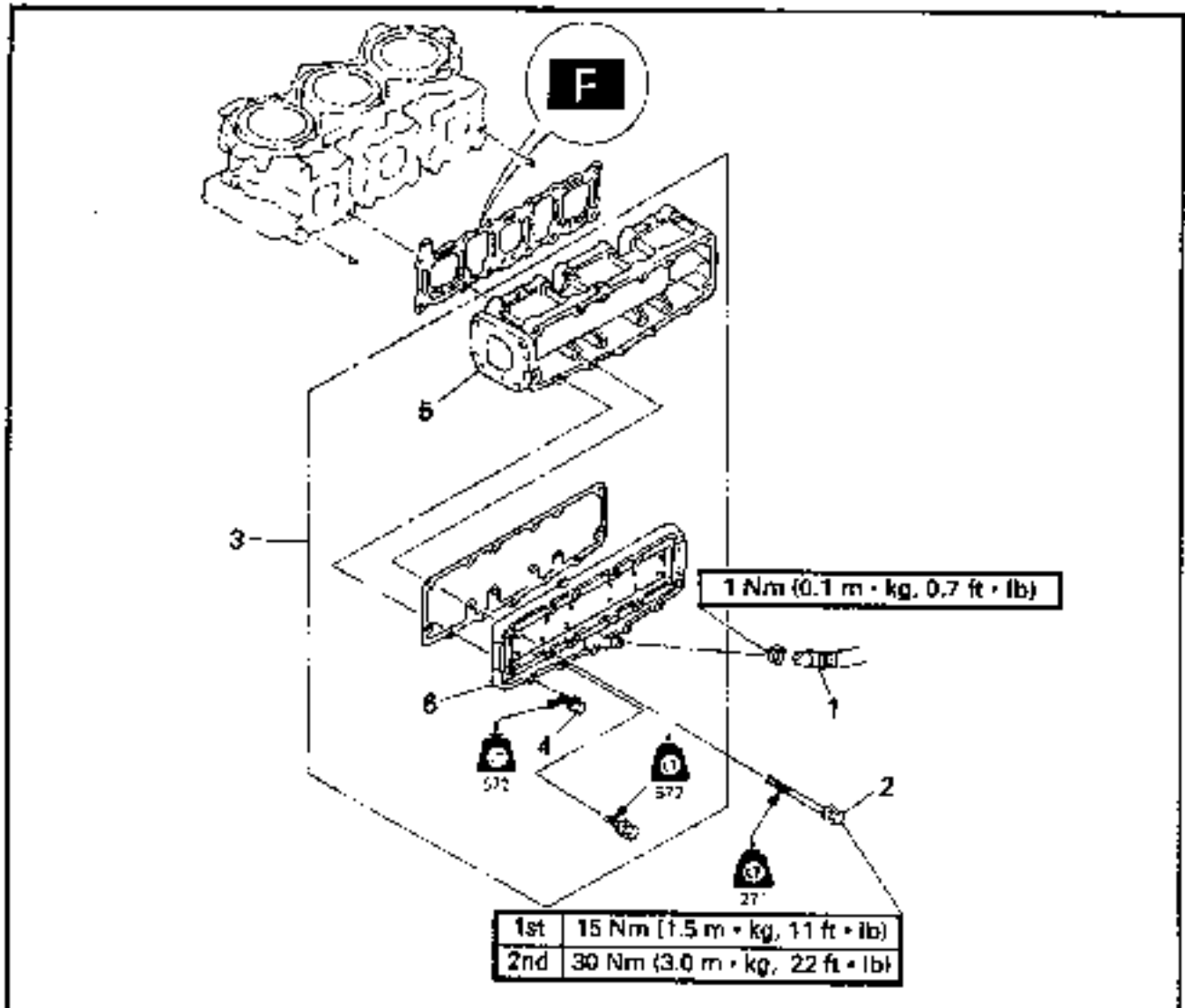

REMOVAL AND INSTALLATION CHART

Step	Procedure/Part name	Qty	Service points
	<b>MUFFLER REMOVAL</b>		Follow the left "Step" for removal. Refer to "EXHAUST CHAMBER REMOVAL".
1	Exhaust chamber assembly		
1	Water inlet hose	1	
2	Bolt (with washer)	12	M6 x 120 mm
3	Muffler assembly	1	<b>NOTE:</b> _____
4	Bolt (with washer)	5	Tighten the bolts in sequence and two steps of torque.
5	Muffler 1	1	_____
6	Muffler cover	1	
			Reverse the removal steps for installation.



**CYLINDER HEAD**  
**EXPLODED DIAGRAM (GP760)**

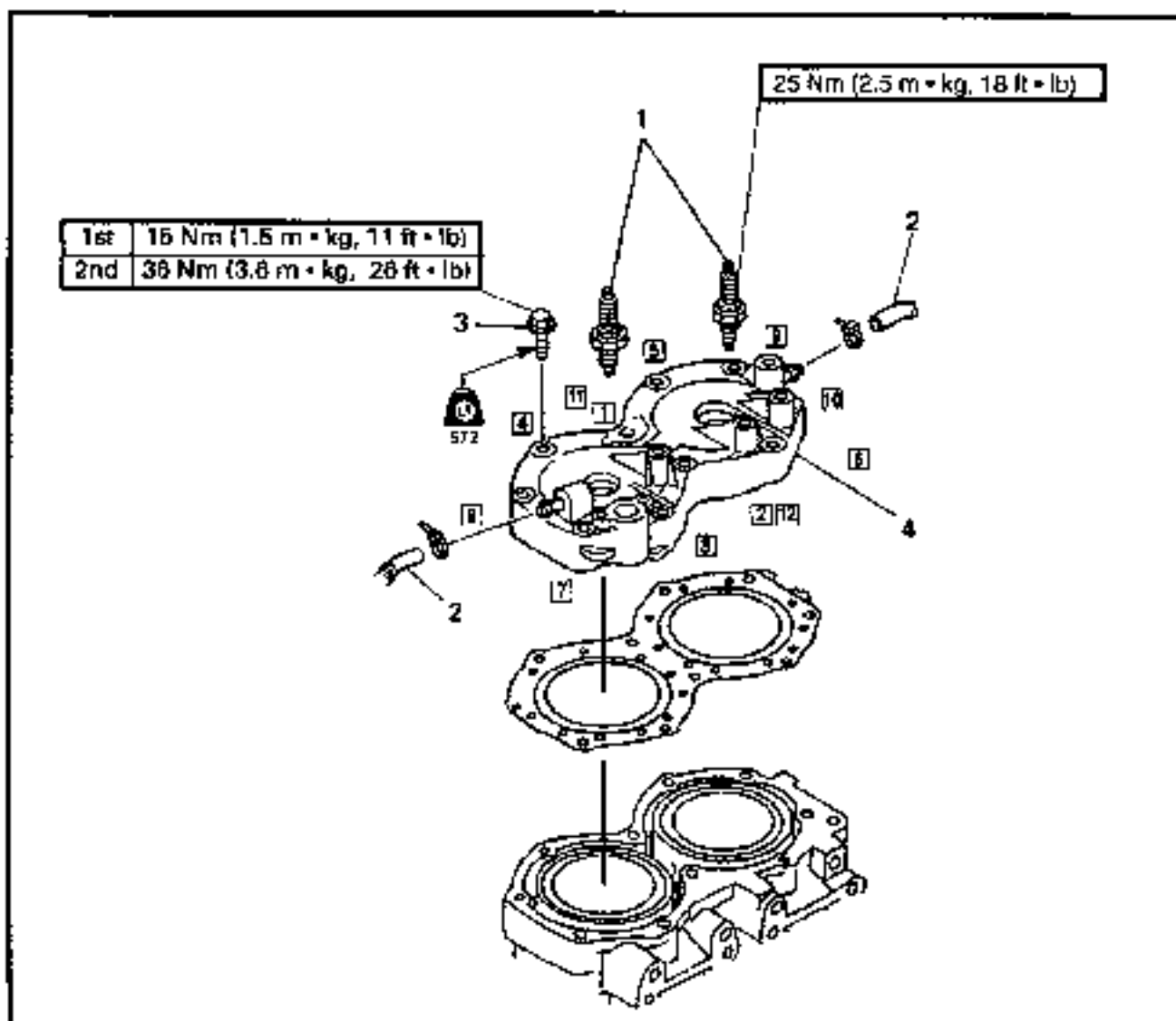

**REMOVAL AND INSTALLATION CHART**

Step	Procedure/Part name	Q'ty	Service points
	<b>CYLINDER HEAD REMOVAL</b>		
	Muffler		Follow the left "Step" for removal. Refer to "MUFFLER".
1	Spark plug	2	<b>NOTE:</b> _____ Tighten the bolts in sequence and two steps of torque. _____
2	Water hose	2	
3	Bolt (with washer)	10	
4	Cylinder head	1	Reverse the removal steps for installation.





EXPLODED DIAGRAM (GP1200)

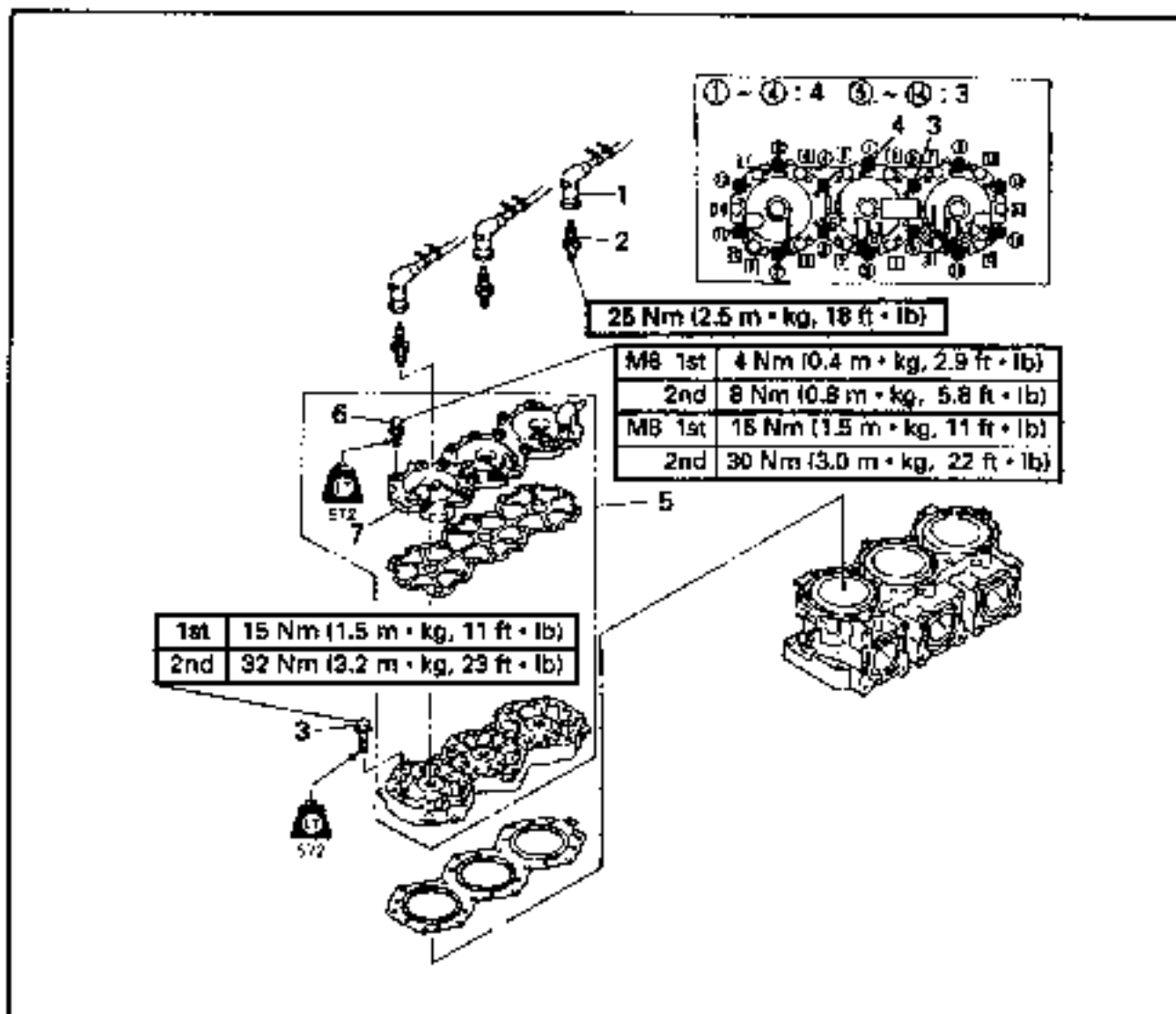

REMOVAL AND INSTALLATION CHART

Step	Procedure/Part name	Q'ty	Service points
	<b>CYLINDER HEAD REMOVAL</b>		
	Muller stay		Follow the left "Step" for removal. Refer to "EXHAUST CHAMBER".
1	Spark plug cap	3	
2	Spark plug	3	
3	Bolt (with washer)	11	M8 x 50 mm
4	Bolt (with washer)	4	M8 x 65 mm
5	Cylinder head	1	<b>NOTE:</b> _____
6	Bolt (with washer)	15	Tighten the bolts in sequence and two steps of torque.
7	Cylinder head cover	1	_____
			Reverse the removal steps for installation.

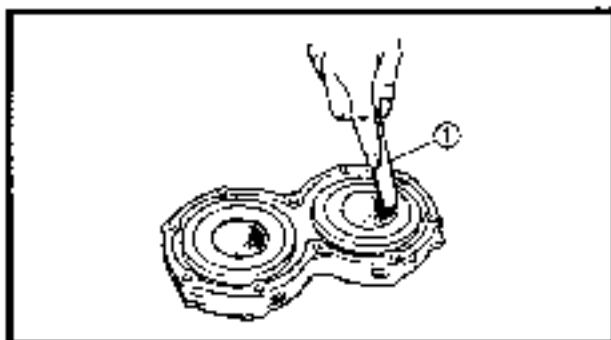

## SERVICE POINTS

### Cylinder head inspection

1. Eliminate:
  - Carbon deposits
  - Use a rounded scraper (1).

### NOTE:

Take care to avoid damaging the spark plug threads. Do not use a sharp instrument. Avoid scratching the aluminum.

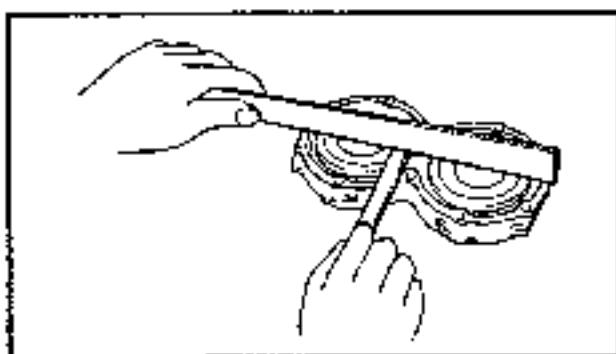

2. Inspect:
  - Cylinder head water jacket
  - Mineral deposits/Corrosion → Clean.
3. Measure:
  - Cylinder head warpage
  - Out of specification → Resurface.



**Warpage limit:**  
0.1 mm (0.004 in)

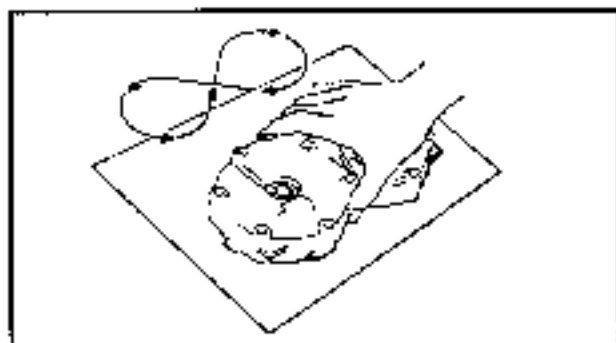

### Warpage measurement and resurfacing steps:

- Attach a straight edge and a thickness gauge on the cylinder head.
- Measure the warpage.
- If the warpage is out of specification, resurface the cylinder head.
- Place a 400 - 600 grit wet sandpaper on the surface plate, and resurface the head using a figure-eight sanding pattern.



**CYLINDER  
EXPLODED DIAGRAM (GP760)**

1st	23 Nm (2.3 m • kg, 17 ft • lb)
2nd	40 Nm (4.0 m • kg, 29 ft • lb)

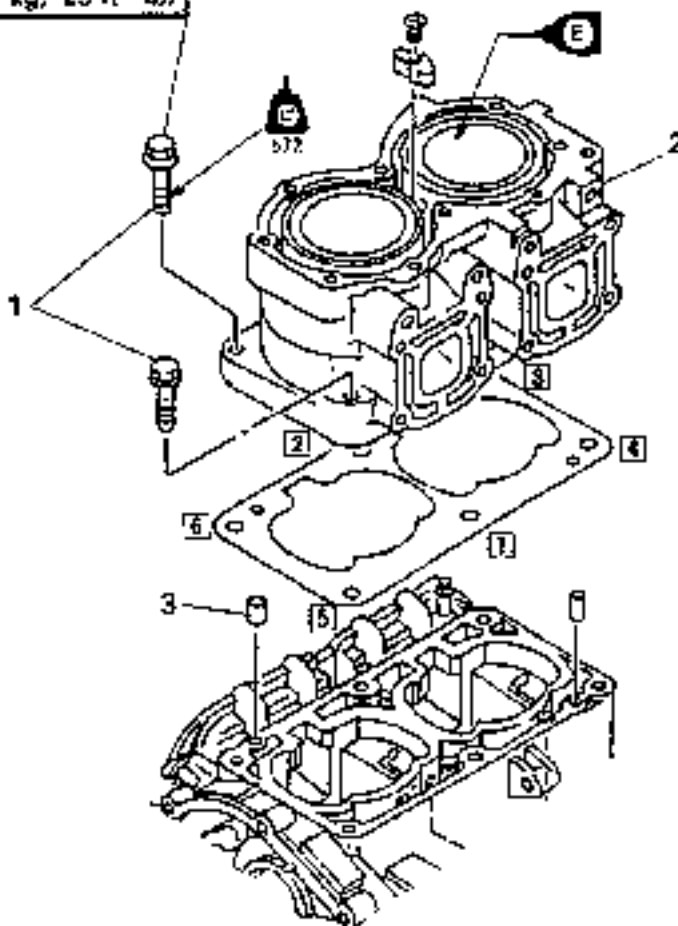

**REMOVAL AND INSTALLATION CHART**

Step	Procedure/Part name	Q'ty	Service points
<b>CYLINDER REMOVAL</b>			
1	Cylinder head Bolt (with washer)	6	Follow the left "Step" for removal. Refer to "CYLINDER HEAD". <b>NOTE:</b> _____ Tighten the bolts in sequence and in two steps of torque.
2	Cylinder	1	<b>NOTE:</b> _____ After installing, check the smooth movement of the piston
3	Pin	2	Reverse the removal steps for installation.



EXPLODED DIAGRAM (GP1200)

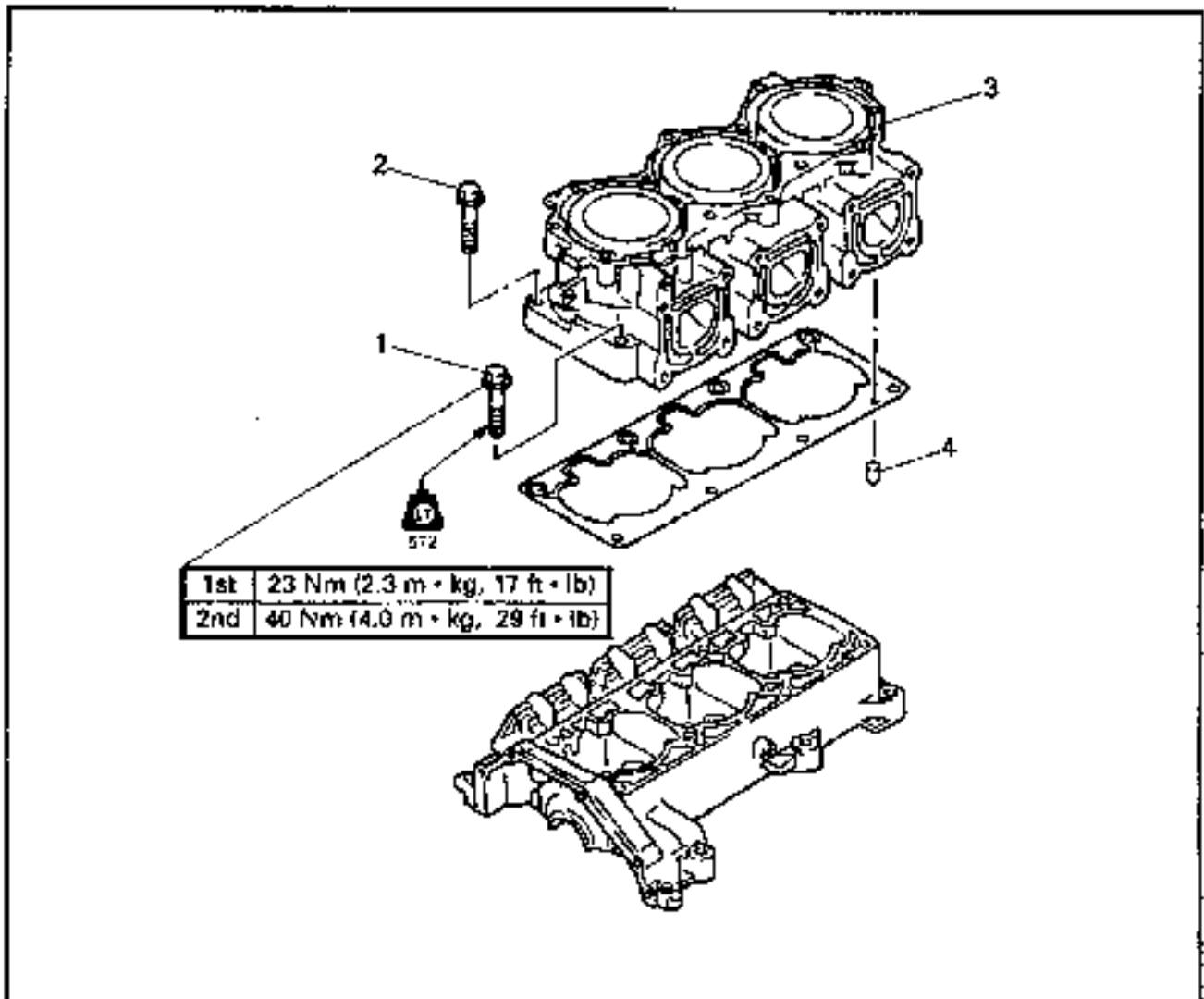

REMOVAL AND INSTALLATION CHART

Step	Procedure/Part name	Q'ty	Service points
<b>CYLINDER REMOVAL</b>			
	Cylinder head		Follow the left "Step" for removal. Refer to "CYLINDER HEAD".
1	Bolt (with washer)	2	M10 x 55 mm
2	Bolt (with washer)	6	M10 x 40 mm
			<b>NOTE:</b> _____ Tighten the bolts in sequence and in two steps of torque
3	Cylinder	1	<b>NOTE:</b> _____
4	Pin	2	After installing, check the smooth movement of the piston.
			Reverse the removal steps for installation.

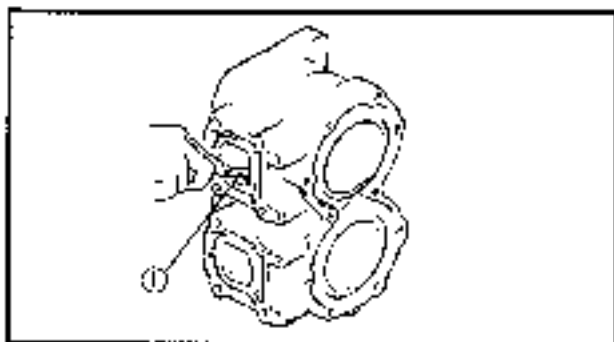

**SERVICE POINTS**

**Cylinder inspection**

1. Eliminate:
  - Carbon deposits  
Use a rounded scraper ①.
  
2. Inspect:
  - Cylinder water jacket  
Mineral deposits/Corrosion → Clean.
  - Cylinder inner surface  
Score marks → Repair or replace.  
Use #600 - 800 grit wet sandpaper.
  
3. Measure:
  - Cylinder bore "D"  
Use cylinder gauge.  
Out of limit → Replace.

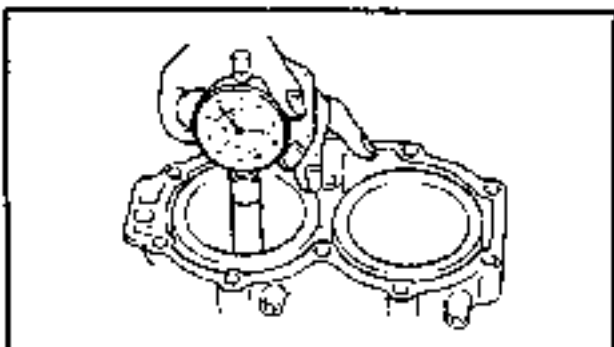

**NOTE:** \_\_\_\_\_  
 Measure the cylinder bore "D" in parallel. Then, find the average of the measurement.

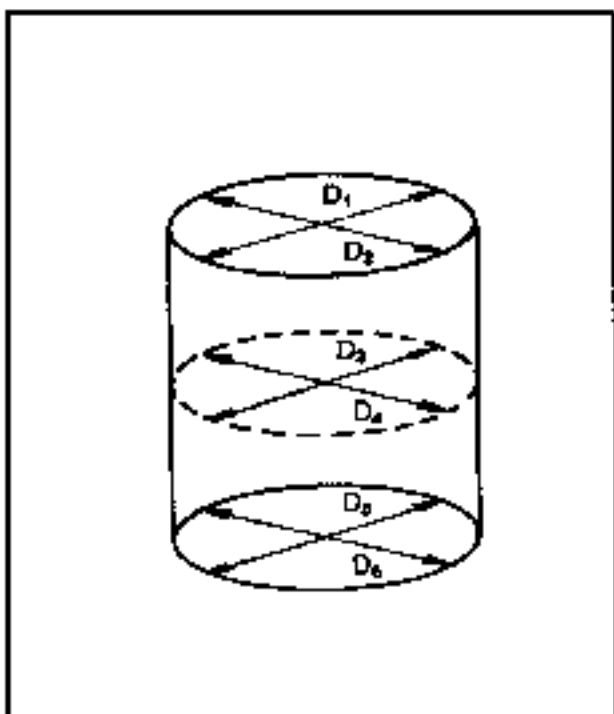

	Standard	Limit
Cylinder bore "D"	64.00 - 64.02 mm (3.307 - 3.308 in)	64.1 mm (3.31 in)
Taper "T"	-	0.08 mm (0.003 in)
Out of round "R"	-	0.05 mm (0.002 in)

$D = \text{Maximum } (D_1, \sim D_6)$   
 $T = (\text{Maximum } D_1 \text{ or } D_2) - (\text{Maximum } D_3 \text{ or } D_4)$   
 $R = (\text{Maximum } D_1, D_3, \text{ or } D_5) - (\text{Minimum } D_2, D_4 \text{ or } D_6)$



**PISTON  
EXPLODED DIAGRAM**

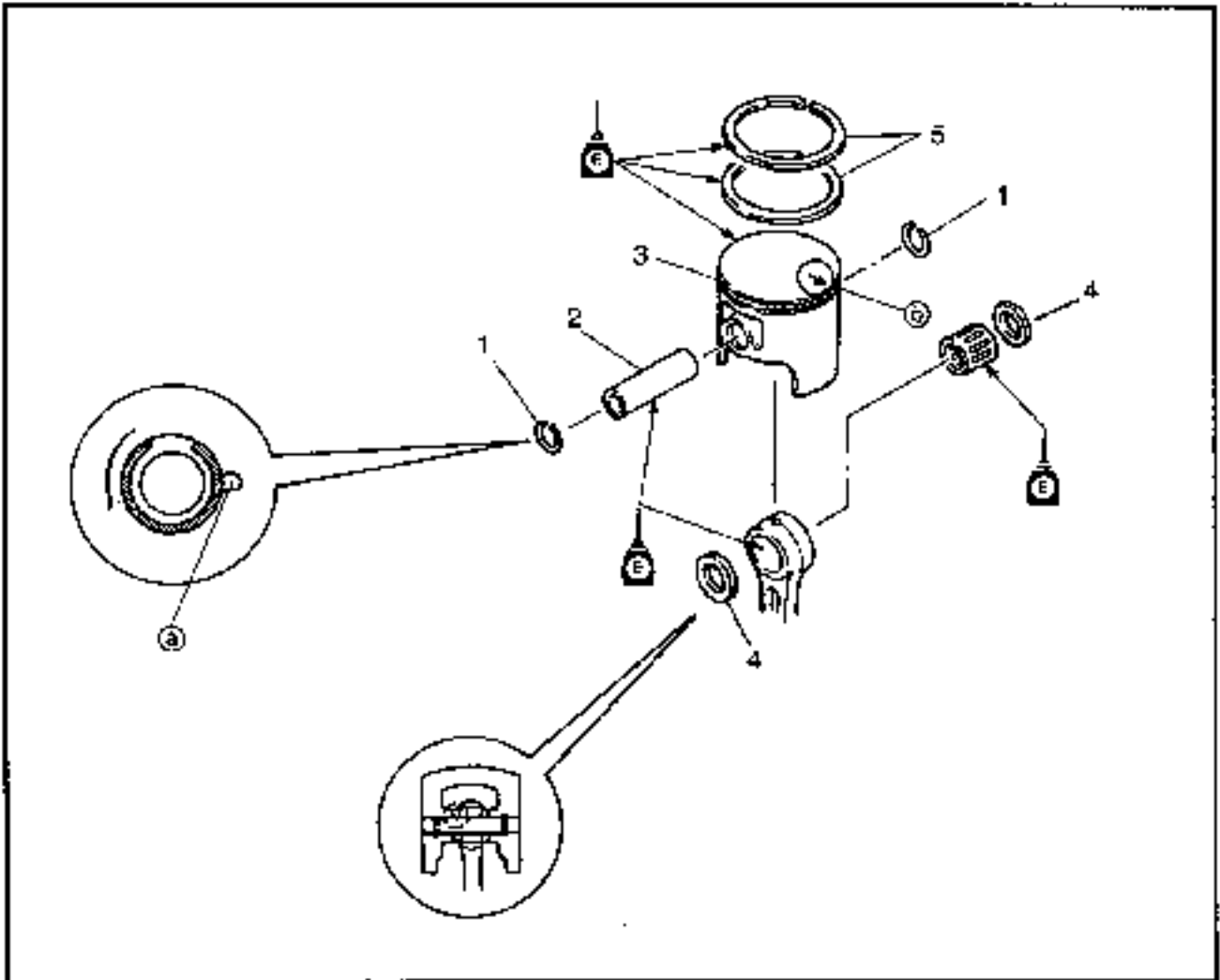

**REMOVAL AND INSTALLATION CHART**

Step	Procedure/Part name	Q'ty	Service points
	<b>PISTON REMOVAL</b>		
	Cylinder	753, 1800	Follow the left "Step" for removal. Refer to "CYLINDER".
1	Piston pin clip	4, 6	<b>Do not allow the clip open ends to meet the piston pin slot (a).</b>
2	Piston pin	2, 3	
3	Piston	2, 3	<b>NOTE:</b> Be sure the arrow (b) side is positioned exhaust side.
4	Washer	4, 6	
5	Piston ring	4, 6	<b>Align each end gap with the locating pin.</b>
			Reverse the removal steps for installation.



**SERVICE POINTS**

**Piston pin clip removal and installation**

1. Remove and install:
  - Piston pin clip

**NOTE:**

Before removing and installing piston pin clip, cover crankcase with a clean rag to prevent piston pin clip from falling into crankcase cavity.

**Piston inspection**

1. Eliminate:
  - Carbon deposits  
From the piston crown and ring groove.

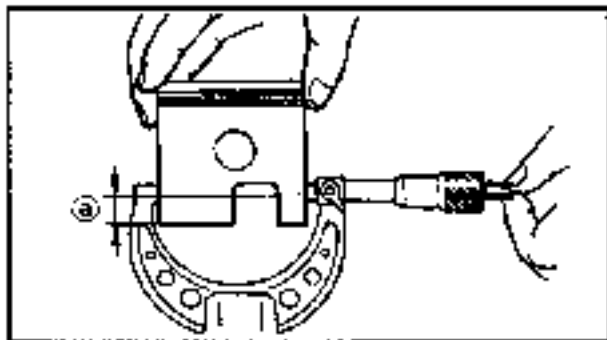
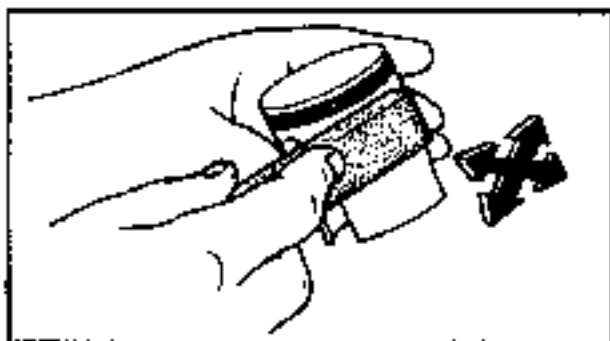

2. Inspect:
  - Piston wall  
Score marks → Repair or replace.  
Use #600 - 800 grit wet sandpaper.

**NOTE:**

Sand in a criss-cross pattern. Do not sand excessively.

3. Measure:
  - Piston skirt diameter  
Use micrometer.  
Out of specification → Replace.

	Piston diameter	Distance (a)
	83.902 - 83.921 mm (3.3032 - 3.3040 in)	10 mm (0.39 in)

4. Calculate:
  - Piston clearance  
Out of limit → Replace piston, piston rings as a set.

$$\boxed{\text{PISTON CLEARANCE}} = \boxed{\text{CYLINDER BORE}} - \boxed{\text{PISTON DIAMETER}}$$

	Piston clearance: 0.100 - 0.105 mm (0.0039 - 0.0041 in)
---	---

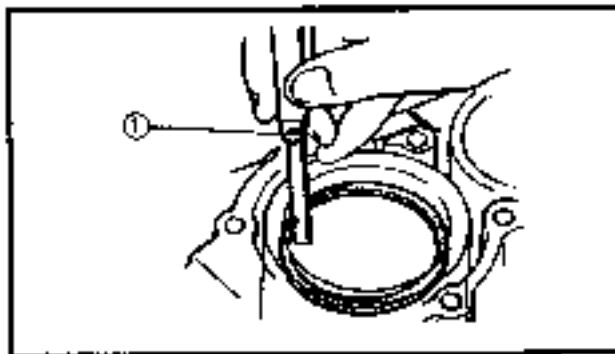
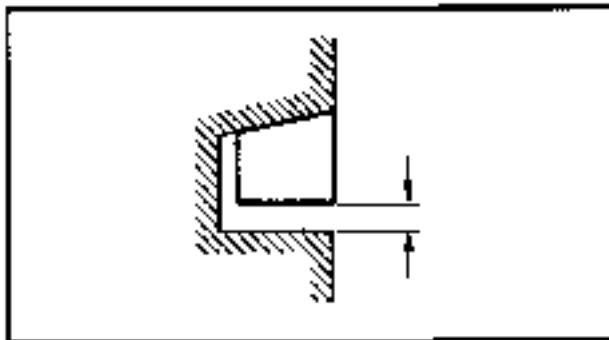
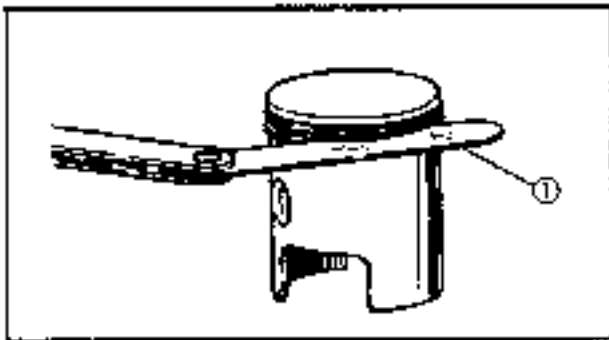

**Piston ring inspection**

1. Measure:

- Side clearance  
Out of specification → Replace piston and/or ring.  
Use a thickness gauge ①.



**Side clearance:**

Top  
2nd  
0.02 - 0.07 mm  
(0.001 - 0.003 in)

2. Measure:

- End gap  
Out of specification → Replace rings as a set.  
Use a thickness gauge ①.



**End gap:**

Top  
2nd  
0.2 - 0.4 mm (0.008 - 0.016 in)

**NOTE:**

- Install the piston ring into the cylinder.
- Push the ring with the piston crown.

**Piston pin and bearing inspection**

1. Inspect:

- Piston pin
- Bearing  
Signs of heat discoloration → Replace.



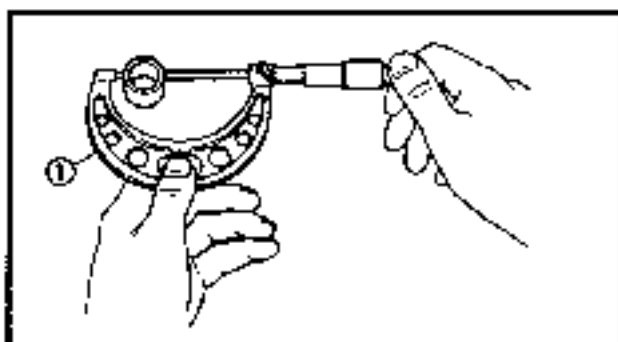

## 2. Measure:

- Piston pin outside diameter  
Use micrometer ①  
Out of limit → Replace.

**Piston pin outside diameter:****Standard**

19.995 - 20.000 mm  
(0.7872 - 0.7874 in)

**Limit**

19.98 mm (0.786 in)

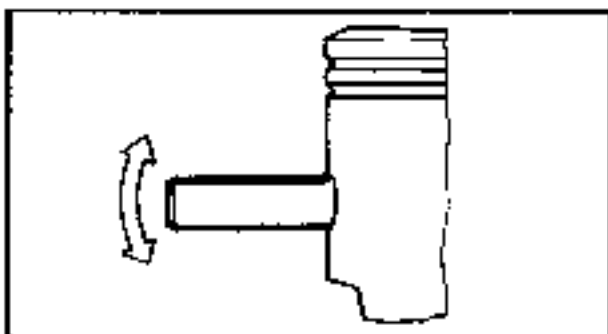

## 3. Check:

- Free play (when the piston pin is in place in the piston)  
There should be no noticeable free play.  
Free play exist → Replace piston pin and/or piston.

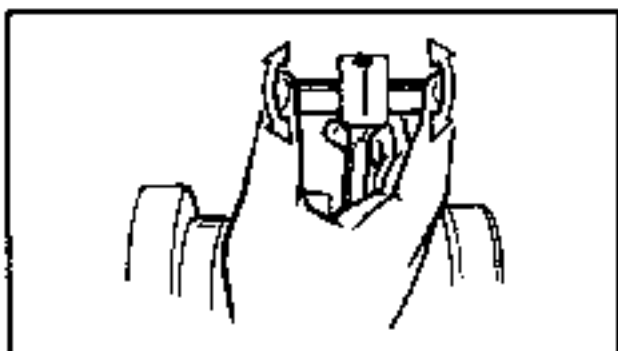

## 4. Check:

- Free play  
There should be no noticeable free play.  
Free play exist → Inspect the connecting rod for wear/Replace the pin and/or connecting rod as required.



**FLYWHEEL MAGNETO AND BASE  
EXPLODED DIAGRAM (GP750)**

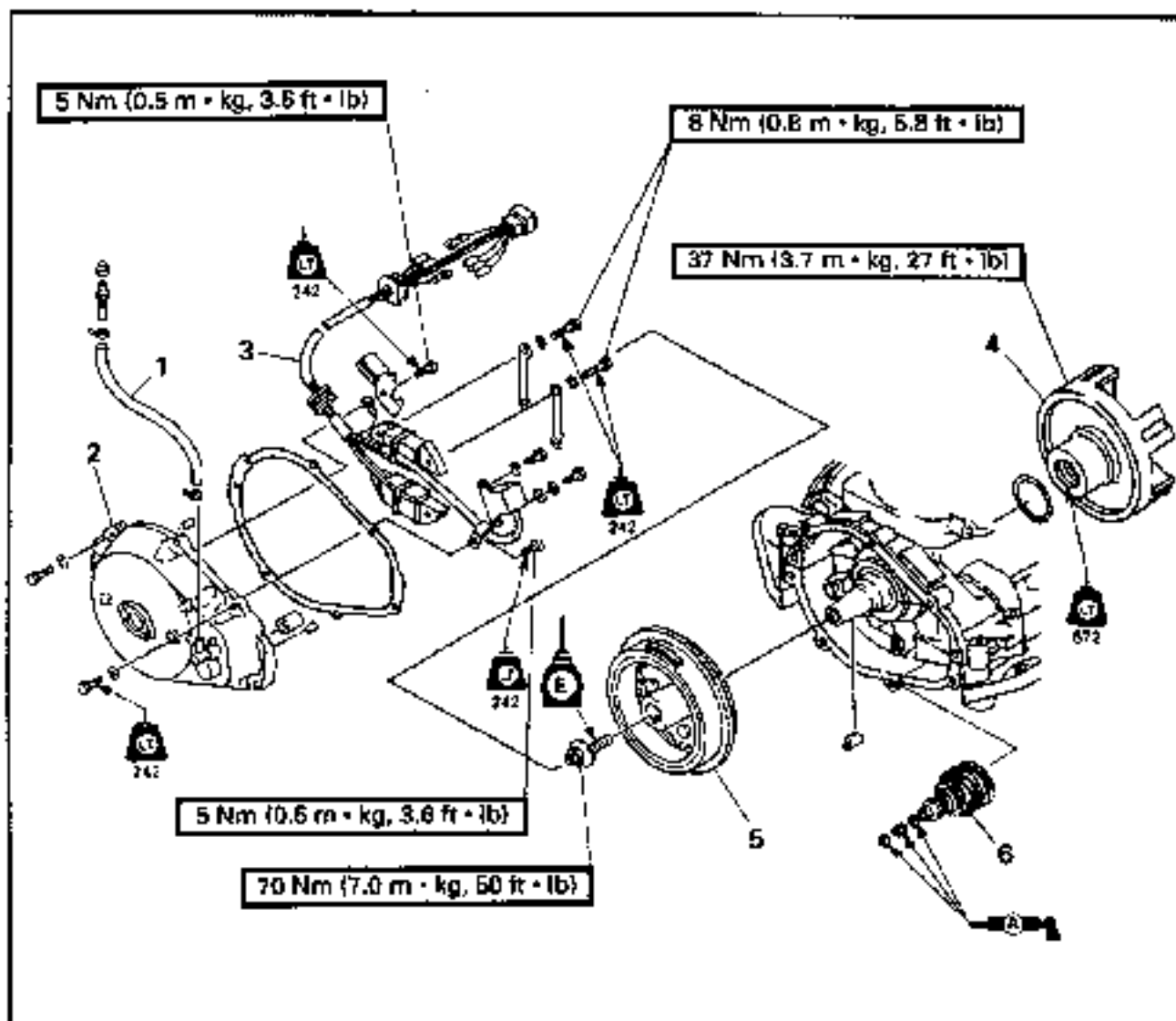

**REMOVAL AND INSTALLATION CHART**

Step	Procedure/Part name	Q'ty	Service points
	<b>FLYWHEEL MAGNETO AND BASE DISASSEMBLY</b>		Follow the left "Step" for removal.
	Engine unit		Refer to "ENGINE UNIT REMOVAL".
	Oil pump		Refer to "OIL PUMP" in chapter 4.
1	Grease hose	1	<b>NOTE:</b> _____ Fill the water resistant grease into the flywheel cover groove. _____ Reverse the removal steps for installation.
2	Flywheel cover	1	
3	Base assembly	1	
4	Coupling flange	1	
5	Flywheel magneto	1	
6	Idle gear assembly	1	



EXPLODED DIAGRAM (GP1200)

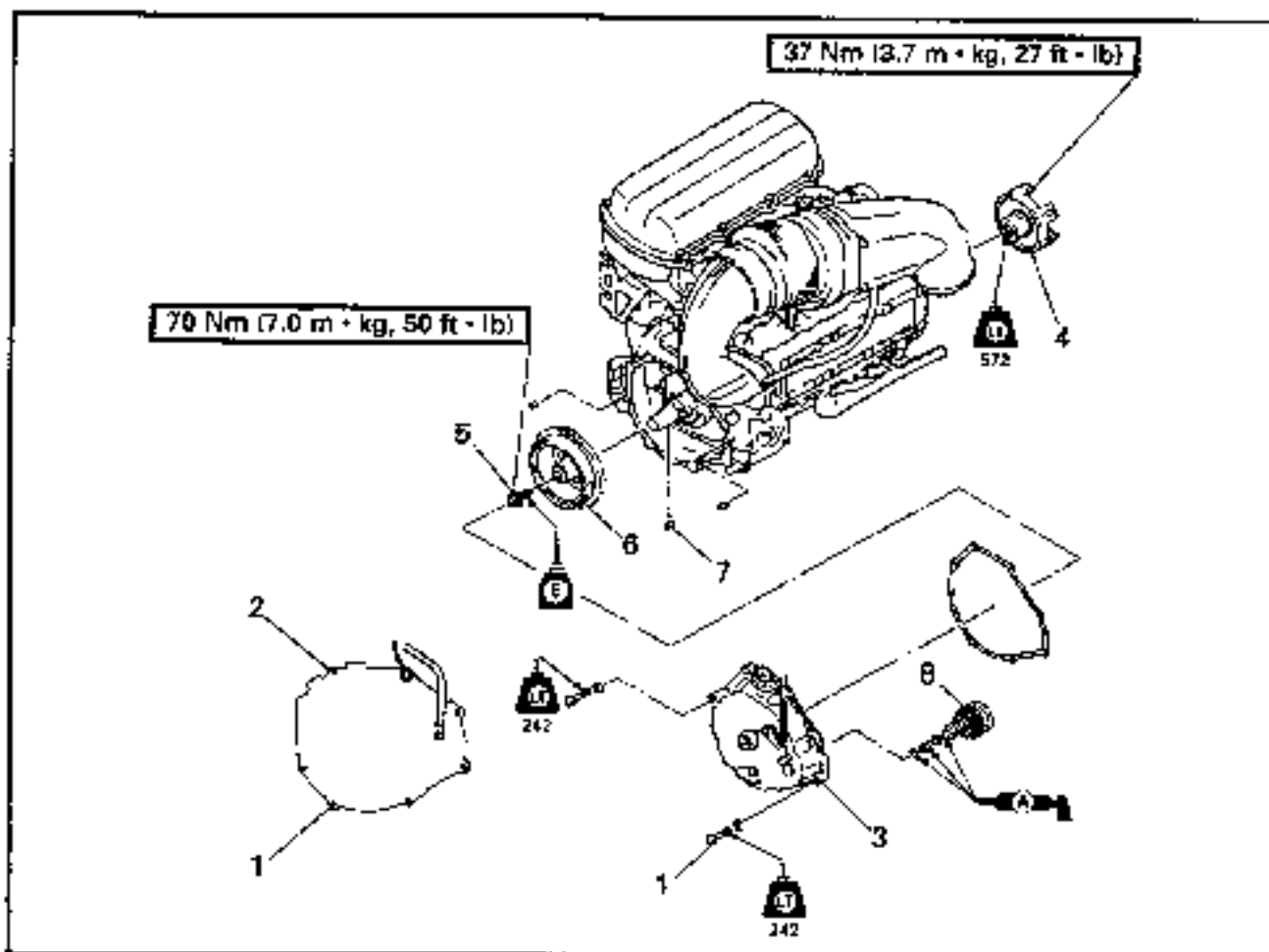

REMOVAL AND INSTALLATION CHART

Step	Procedure/Part name	Q'ty	Service points
	<b>FLYWHEEL MAGNETO AND BASE DISASSEMBLY</b>		Follow the left "Step" for removal.
	Engine unit		Refer to "ENGINE UNIT REMOVAL".
	Oil pump		Refer to "OIL PUMP" in chapter 4.
1	Bolt (with washer)	6	M8 x 30 mm
2	Bolt (with washer)	1	M8 x 55 mm
3	Flywheel cover assembly	1	
4	Coupling flange	1	
5	Flange bolt	1	
6	Flywheel magneto	1	
7	Woodruff key	1	
8	Idle gear assembly	1	
			<b>NOTE:</b> _____ Fill the water resistant grease into the flywheel cover groove. _____
			Reverse the removal steps for installation.

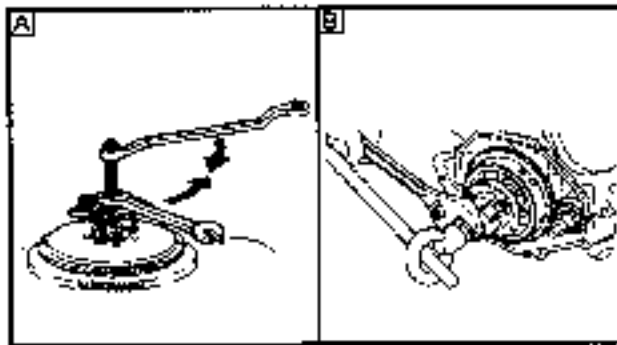
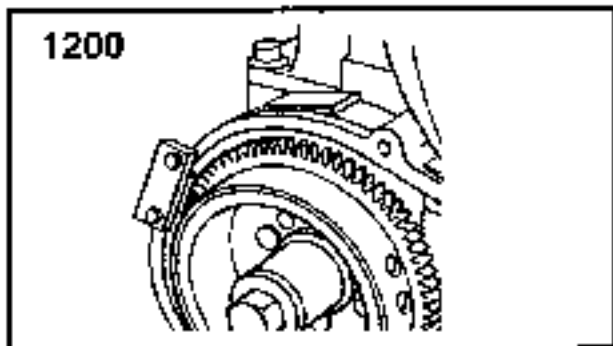
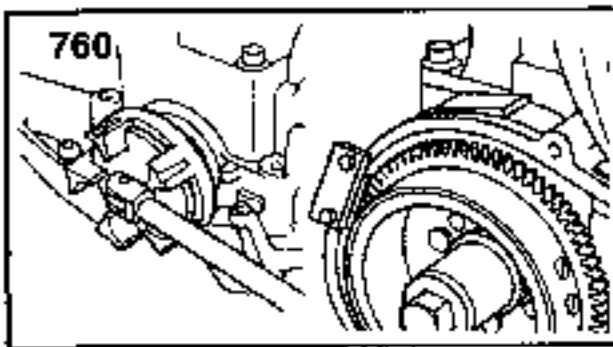

## SERVICE POINTS

### Coupling flange removal and installation

1. Remove and install:
  - Coupling flange



**Coupler wrench:**  
 YW-06546/90890-06546  
**Flywheel holder:**  
 GP760  
 YW-06547/90890-06547  
 GP1200  
 YW-41528/90890-06545

### Flywheel magneto removal and installation

1. Remove and install:
  - Bolt



**Flywheel holder:**  
 GP760  
 YW-06547/90890-06547  
 GP1200  
 YW-41528/90890-06545

2. Remove:
  - Flywheel magneto



**Flywheel pulser:**  
 YB-06117/90890-06521  
**Bolt:**  
 M8 x 60 mm

**A** For USA and CANADA

**B** Except for USA and CANADA

**To prevent damage to the engine or tools, screw in the flywheel pulser set- bolts evenly and completely so that the pulser plate is parallel to the flywheel.**

### Coupling flange inspection

1. Inspect:
  - Coupling flange  
 Wear/Damage → Replace.

### Flywheel magneto inspection

1. Inspect:
  - Flywheel gear  
 Wear/Damage → Replace.

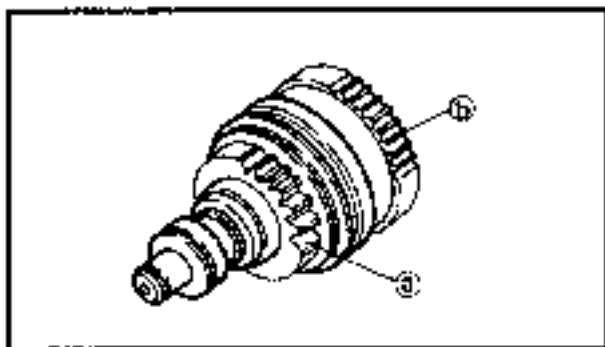
**Idle gear assembly inspection**

## 1. Inspect:

- Pinion gear ③
  - Inner gear ④
- Wear/Damage → Replace.

## 2. Check:

- Clutch movement
- Unsmooth movement → Replace.



**ELECTRICAL UNIT  
EXPLODED DIAGRAM (GP760)**

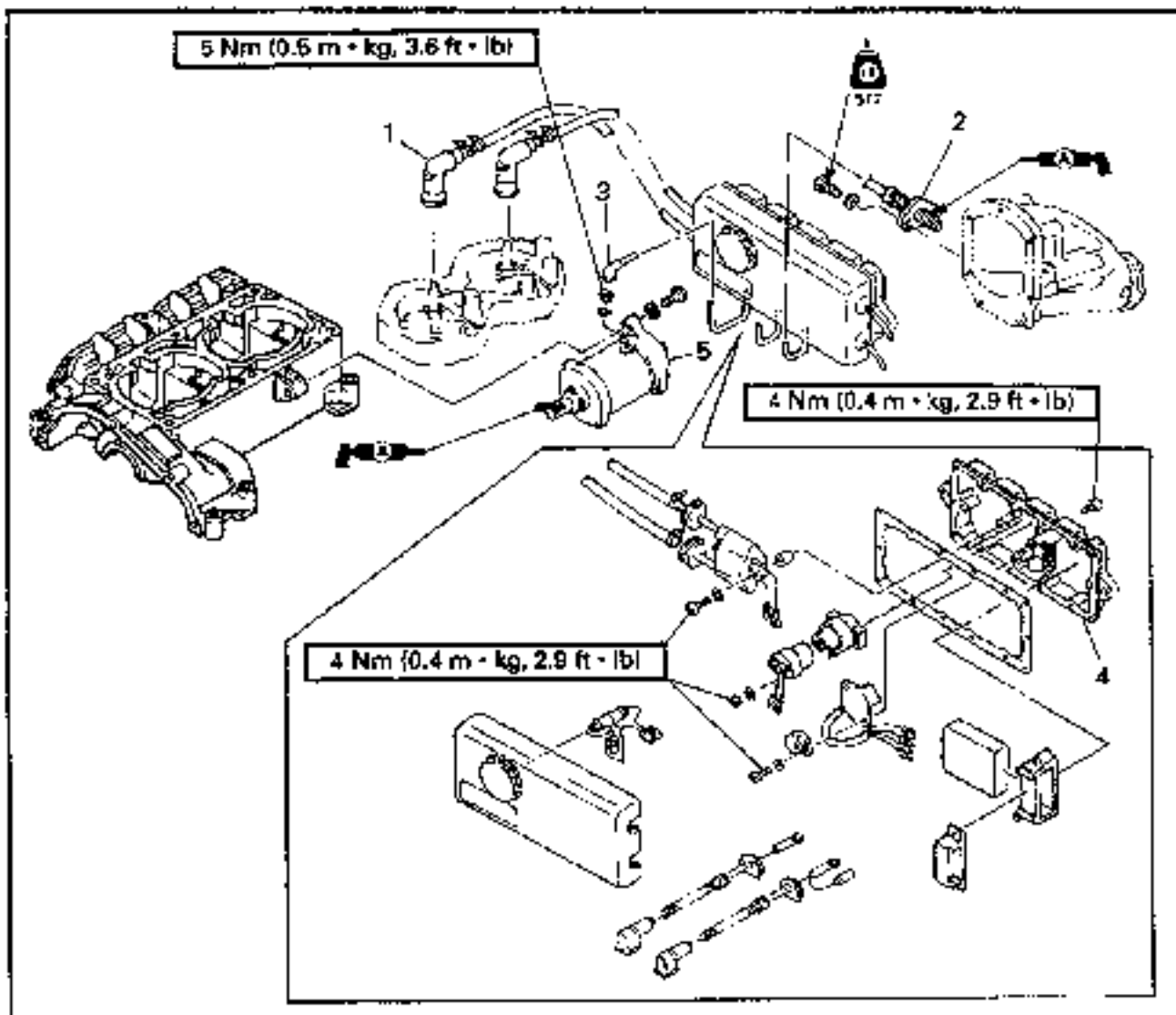

**REMOVAL AND INSTALLATION CHART**

Step	Procedure/Part name	Qty	Service points
	<b>ELECTRICAL UNIT REMOVAL</b>		
	Electrical box		Follow the left "Step" for removal.
	Base assembly		Refer to "ENGINE UNIT REMOVAL".
			Refer to "FLYWHEEL MAGNETO AND BASE".
1	Spark plug cap	2	
2	Thermo switch	1	
3	Starter motor negative lead	1	
4	Housing	1	
5	Starter motor	1	
			Reverse the removal steps for installation.



EXPLODED DIAGRAM (GP1200)

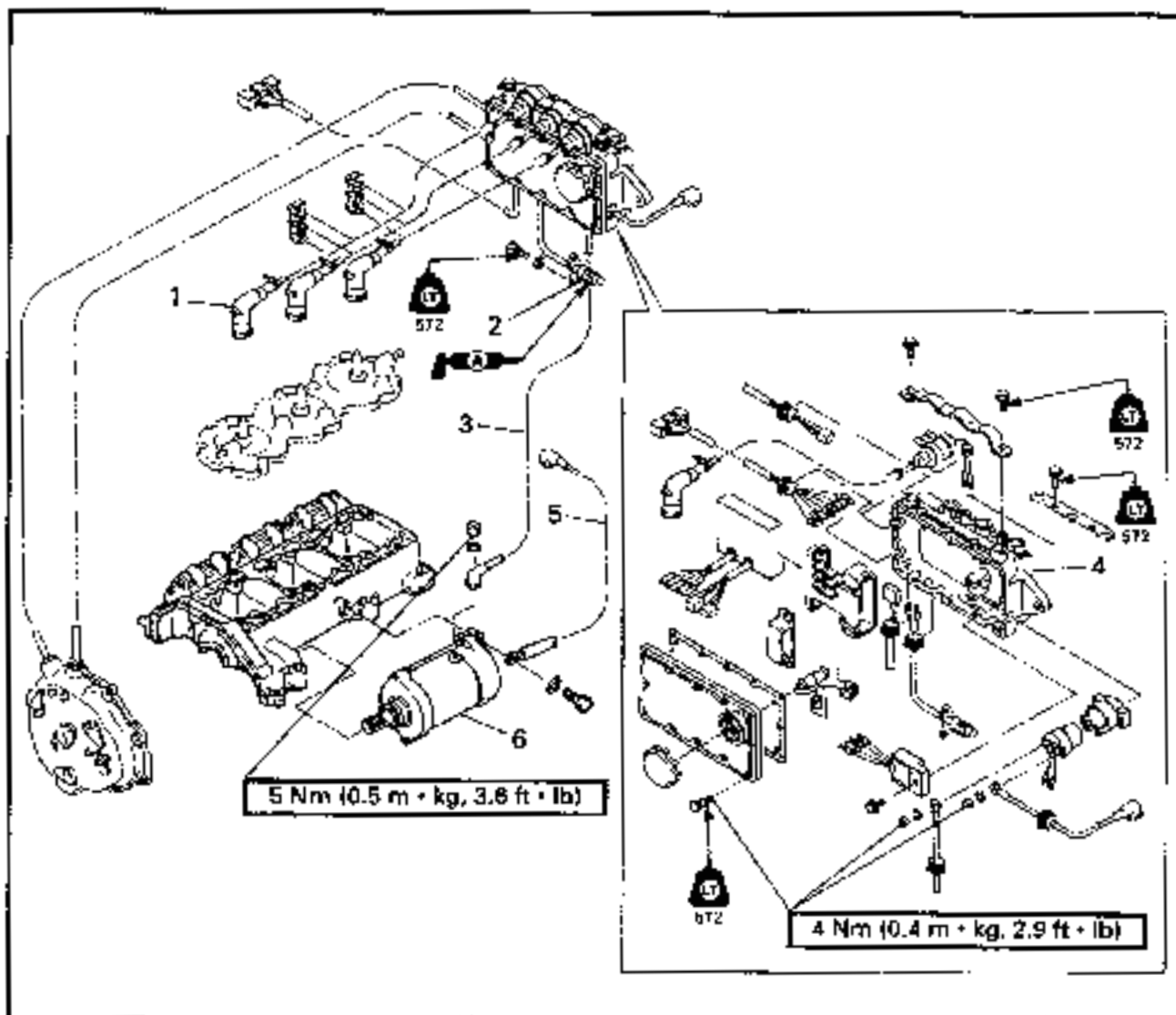

REMOVAL AND INSTALLATION CHART

Step	Procedure/Part name	Q'ty	Service points
	<b>ELECTRICAL UNIT DISASSEMBLY</b>		Follow the left "Step" for removal.
	Electrical box		Refer to "ENGINE UNIT REMOVAL".
	Base assembly		Refer to "FLYWHEEL MAGNETO AND BASE".
1	Spark plug cap	3	
2	Thermo switch	1	
3	Starter motor positive lead	1	
4	Housing	1	
5	Battery cable (negative)	1	
6	Starter motor	1	
			Reverse the removal steps for installation



**STARTER MOTOR  
EXPLODED DIAGRAM**

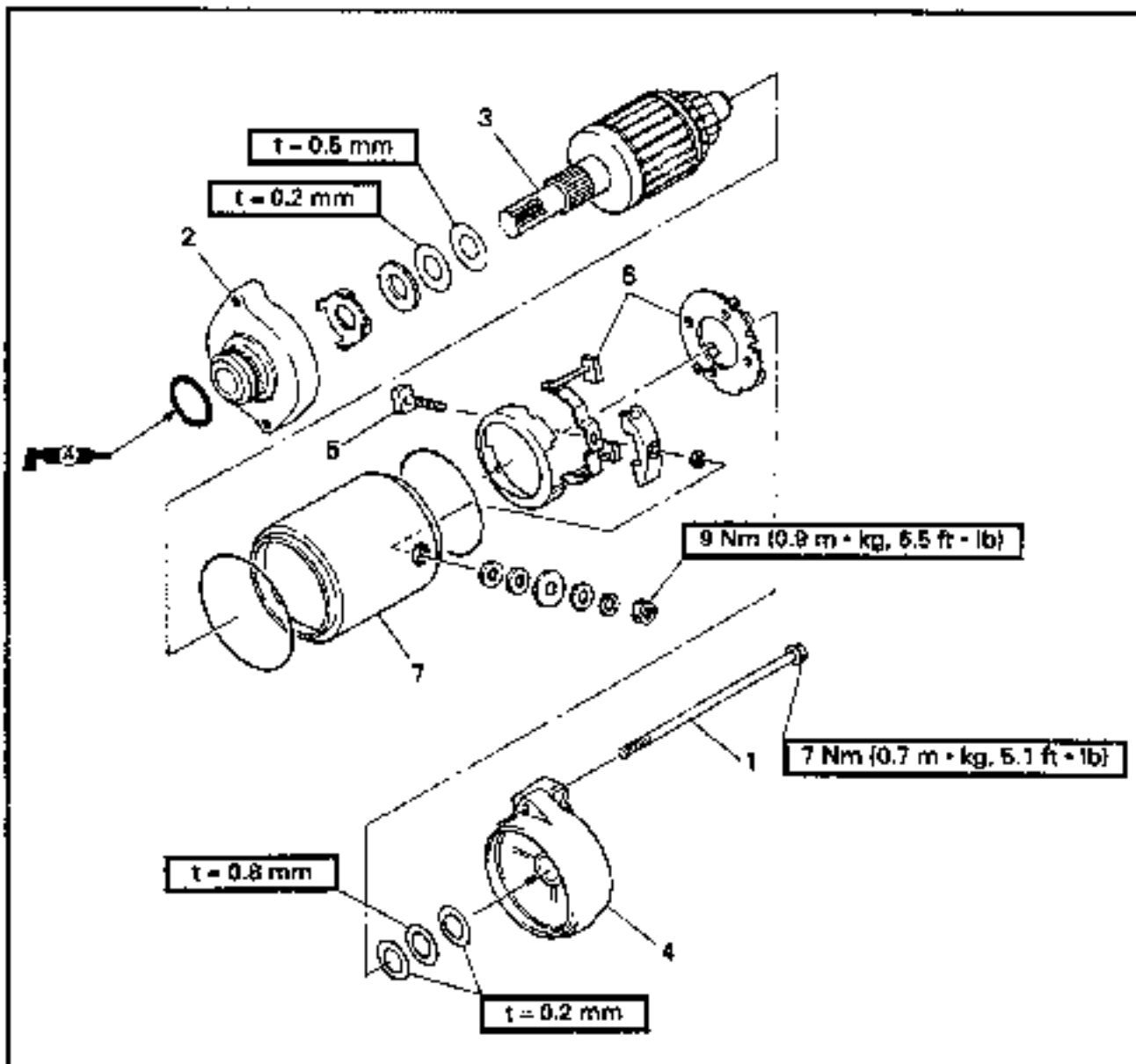

**REMOVAL AND INSTALLATION CHART**

Step	Procedure/Part name	Q'ty	Service points
	<b>STARTER MOTOR DISASSEMBLY</b>		
	Starter motor assembly		Follow the left "Step" for removal. Refer to "ELECTRICAL UNIT".
1	Through bolt	2	
2	Front bracket	1	
3	Armature assembly	1	
4	Rear bracket	1	
5	Bolt	1	
6	Brush holder	1	
7	York assembly	1	
			Reverse the removal steps for installation.



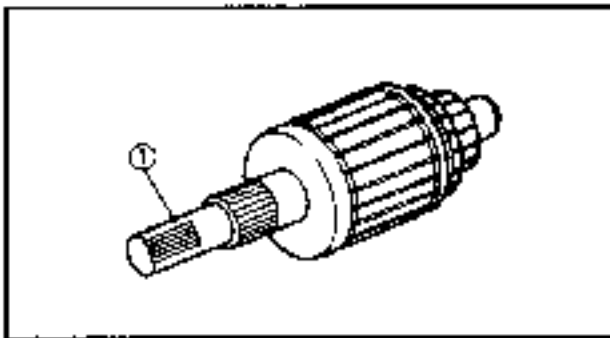

**SERVICE POINTS**

**Pinion inspection**

1. Inspect:
  - Pinion teeth ①  
Wear/Damage → Replace.

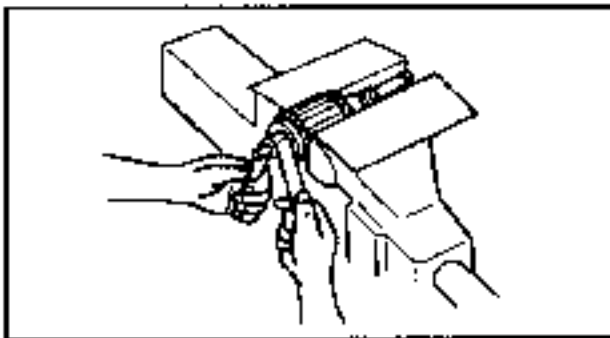

**Armature inspection**

1. Inspect:
  - Commutator  
Dirty → Clean with #600 abrasive paper.

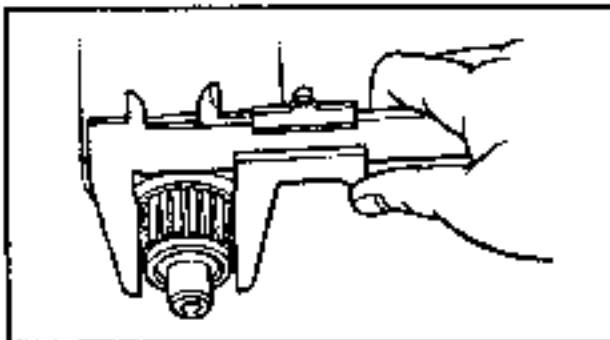

2. Measure:
  - Commutator diameter  
Out of specification → Replace.

	<p><b>Commutator diameter:</b> Limit 27 mm (1.06 in)</p>
--	--

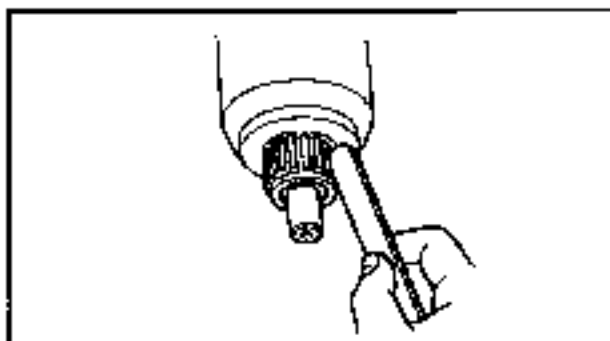

3. Check:
  - Commutator undercut  
Clog/Dirty → Clean.

**NOTE:** \_\_\_\_\_  
Remove all particles of mica and metal using compressed air.  
\_\_\_\_\_

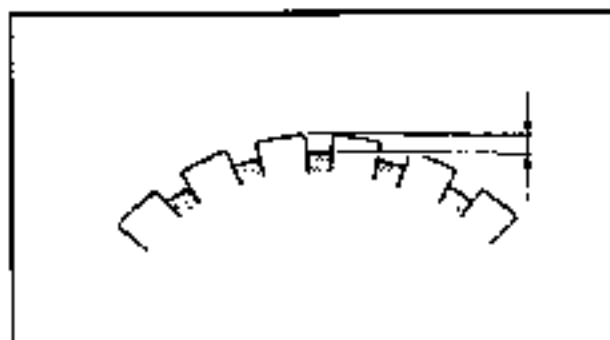

4. Measure:
  - Commutator undercut  
Out of specification → Replace.

	<p><b>Commutator undercut:</b> Limit 0.2 mm (0.01 in)</p>
--	---

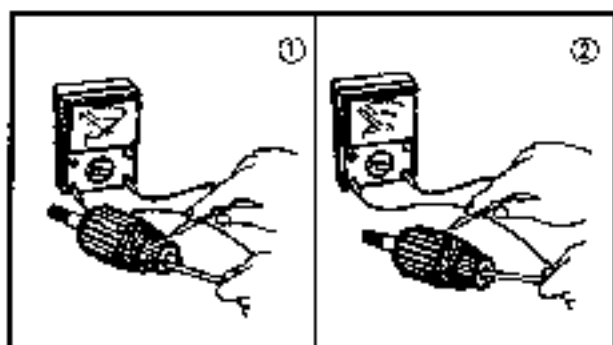

5. Inspect:

- Armature coil continuity  
Out of specification → Replace.

 <b>Armature coil continuity:</b>	
Commutator segments ①	Continuity
Segment - Laminations ②	Discontinuity
Segment - Shaft	Discontinuity

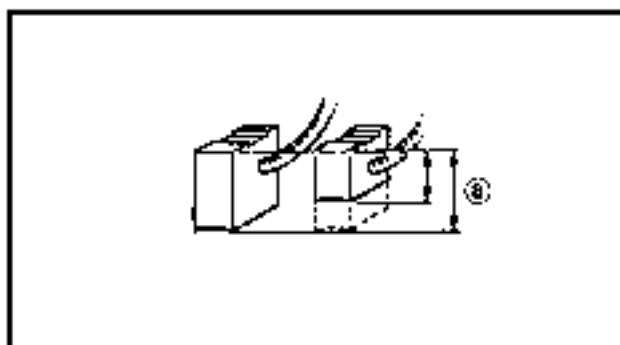

Brush holder inspection

1. Measure:
  - Brush length ⓐ  
Out of specification → Replace.

 <b>Brush length:</b> Limit 6.5 mm (0.26 in)
--

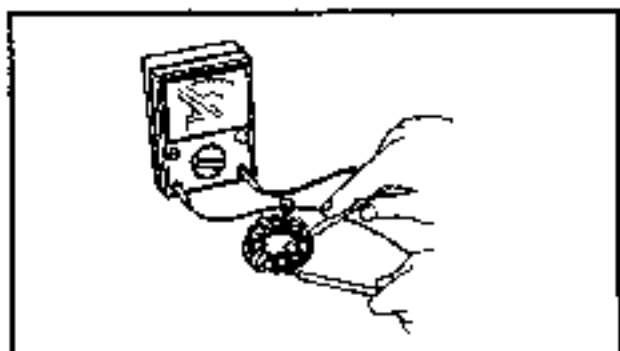

2. Check:
  - Brush holder continuity  
Out of specification → Replace.

 <b>Brush holder continuity:</b>	
Brush holder - Base	Discontinuity

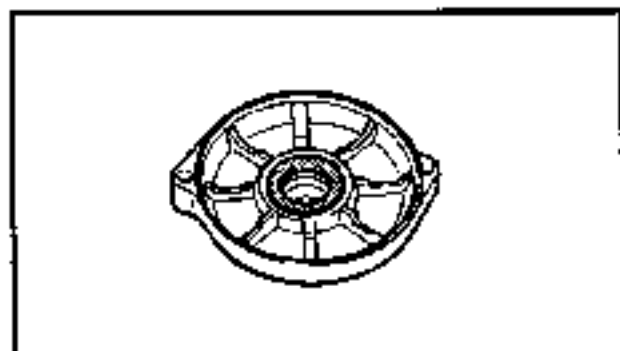

Cover inspection

1. Inspect:
  - Cover bushing  
Wear/Damage → Replace the cover.



**CRANKCASE**

**EXPLODED DIAGRAM (GP760)**

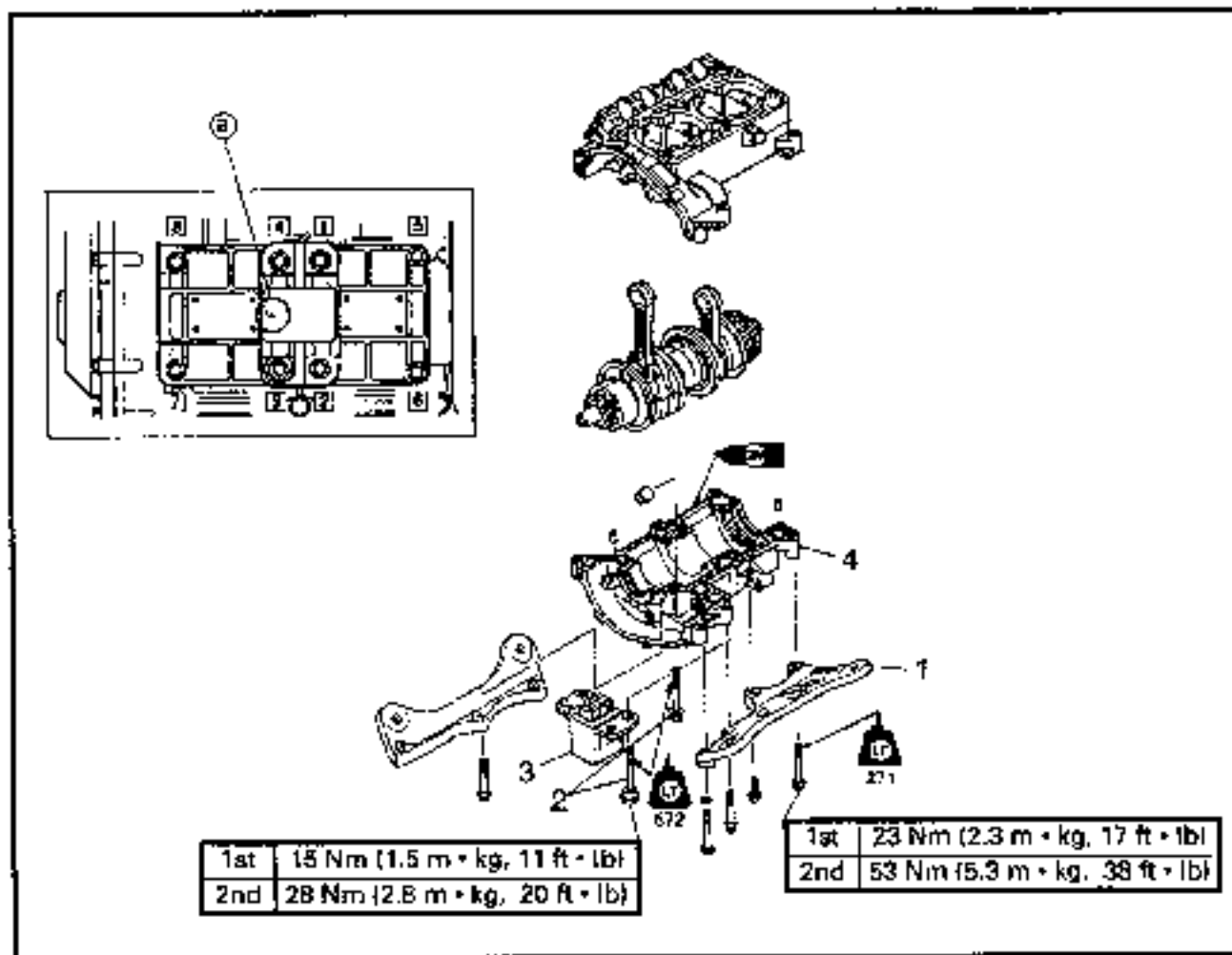

**REMOVAL AND INSTALLATION CHART**

Step	Procedure/Part name	Q'ty	Service points
	<b>CRANKCASE DISASSEMBLY</b>		
	Base assembly		Follow the left "Step" for removal. Refer to "FLYWHEEL MAGNETO AND BASE".
	Starter motor		Refer to "ELECTRICAL UNIT".
	Piston		Refer to "PISTON".
1	Engine mount bracket	2	
2	Bolt (with washer)	8	<b>NOTE:</b> _____ Tighten the bolts in sequence and in two steps of torque.
3	Mount rubber	1	<b>NOTE:</b> _____ Be sure that the "F" mark (a) is on the fly-wheel side.
4	Crankcase	1	Reverse the removal steps for installation.



EXPLODED DIAGRAM (GP1200)

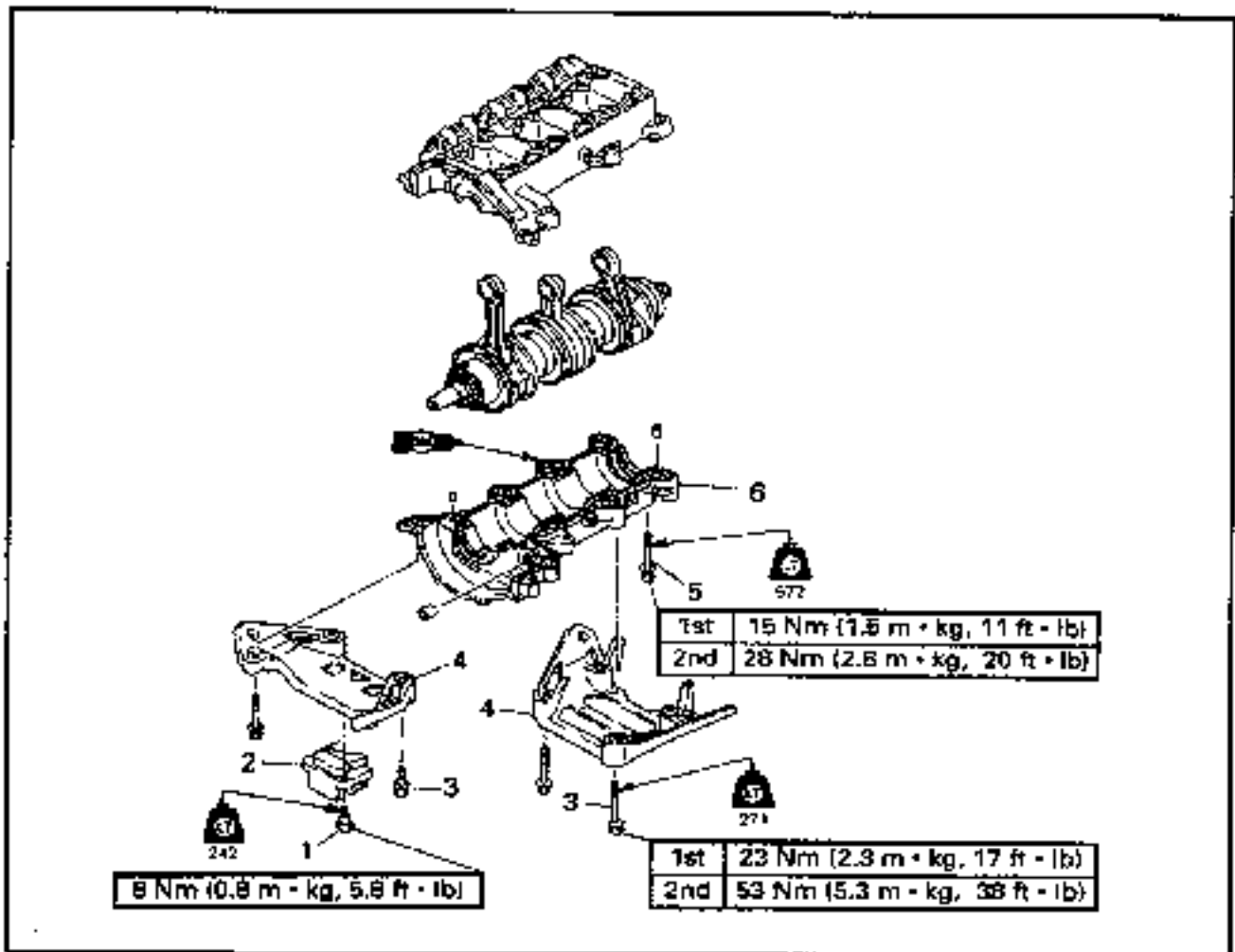

REMOVAL AND INSTALLATION CHART

Step	Procedure/Part name	Q'ty	Service points
	<b>CRANKCASE DISASSEMBLY</b>		
	Base assembly		Follow the left "Step" for removal. Refer to "FLYWHEEL MAGNETO AND BASE".
	Starter motor		Refer to "ELECTRICAL UNIT".
	Piston		Refer to "PISTON".
1	Bolt	2	
2	Mount rubber	1	
3	Bolt (with washer)	9	
4	Engine mount bracket	2	
5	Bolt (with washer)	8	
6	Crankcase	1	<b>NOTE:</b> Tighten the bolts in sequence and in two steps of torque.
			Reverse the removal steps for installation.



## SERVICE POINTS

### Crankcase inspection

1. Inspect:
  - Contacting surface  
Scratch → Replace.
  - Crankcase  
Crack/Damage → Replace.

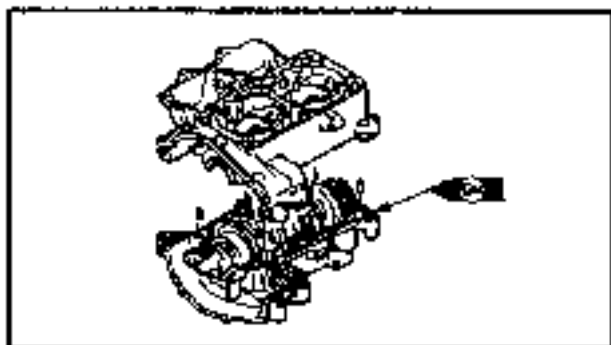

### Crankcase installation

1. Apply:
  - Gasket Maker

#### NOTE:

Clean the contacting surface of crankcase before applying the Gasket Maker.

2. Check:

- Crankshaft  
Rough action → Repair.

#### NOTE:

After installing, check the smooth movement of the crankshaft.



**CRANKSHAFT**  
EXPLODED DIAGRAM (GP760)

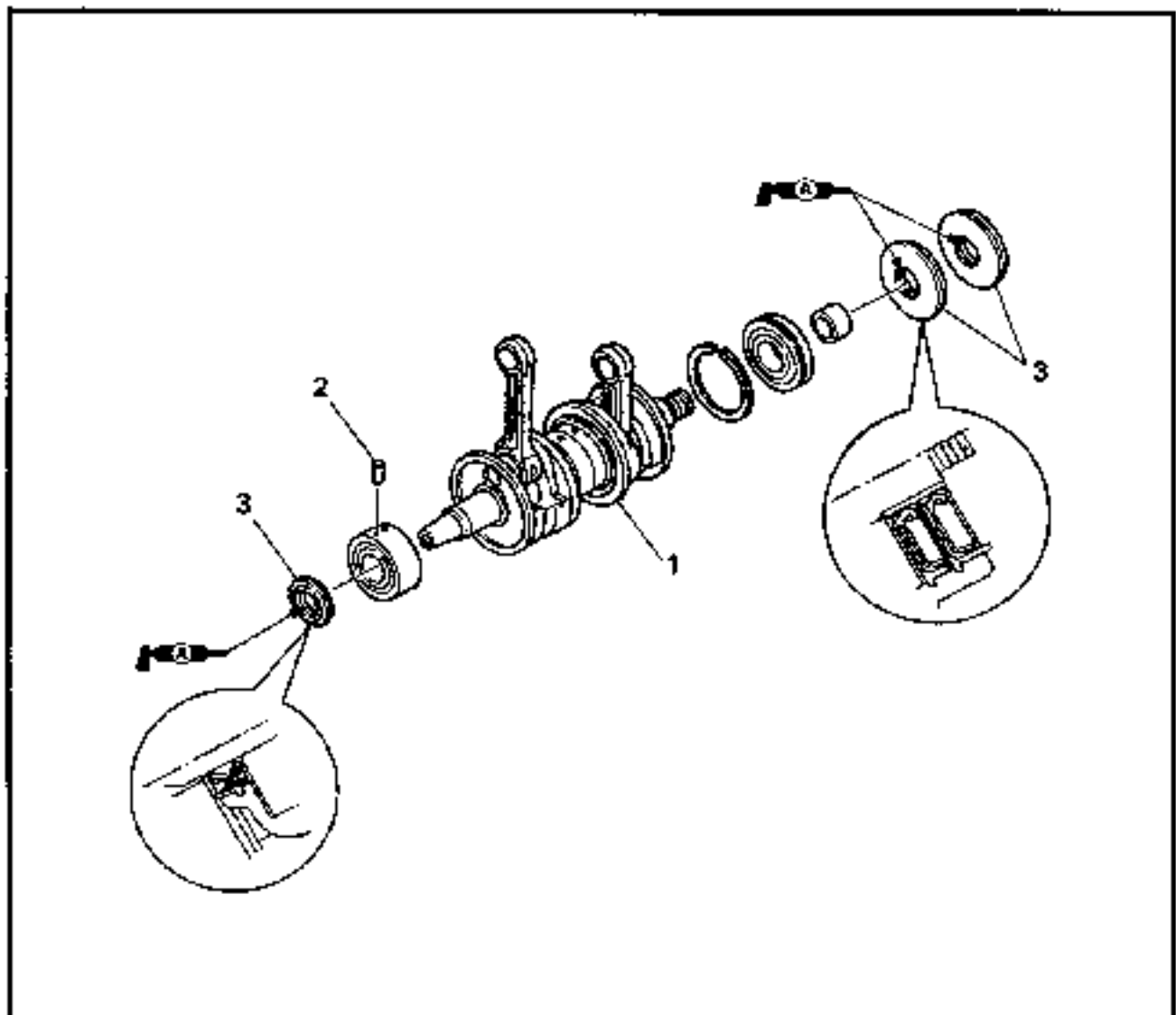

**REMOVAL AND INSTALLATION CHART**

Step	Procedure/Part name	Q'ty	Service points
1	<b>CRANKSHAFT REMOVAL</b> Crankcase Crankshaft assembly	1	Follow the left "Step" for removal. Refer to "CRANKCASE".  <ul style="list-style-type: none"> <li>Do not allow the bearing clip open ends to meet the crankcase contacting surface.</li> <li>Place the locating pins on the bearing into the crankcase body groove.</li> </ul>
2	Dowel pin	5	
3	Oil seal	3	
			Reverse the removal steps for installation.



EXPLODED DIAGRAM (GP1200)

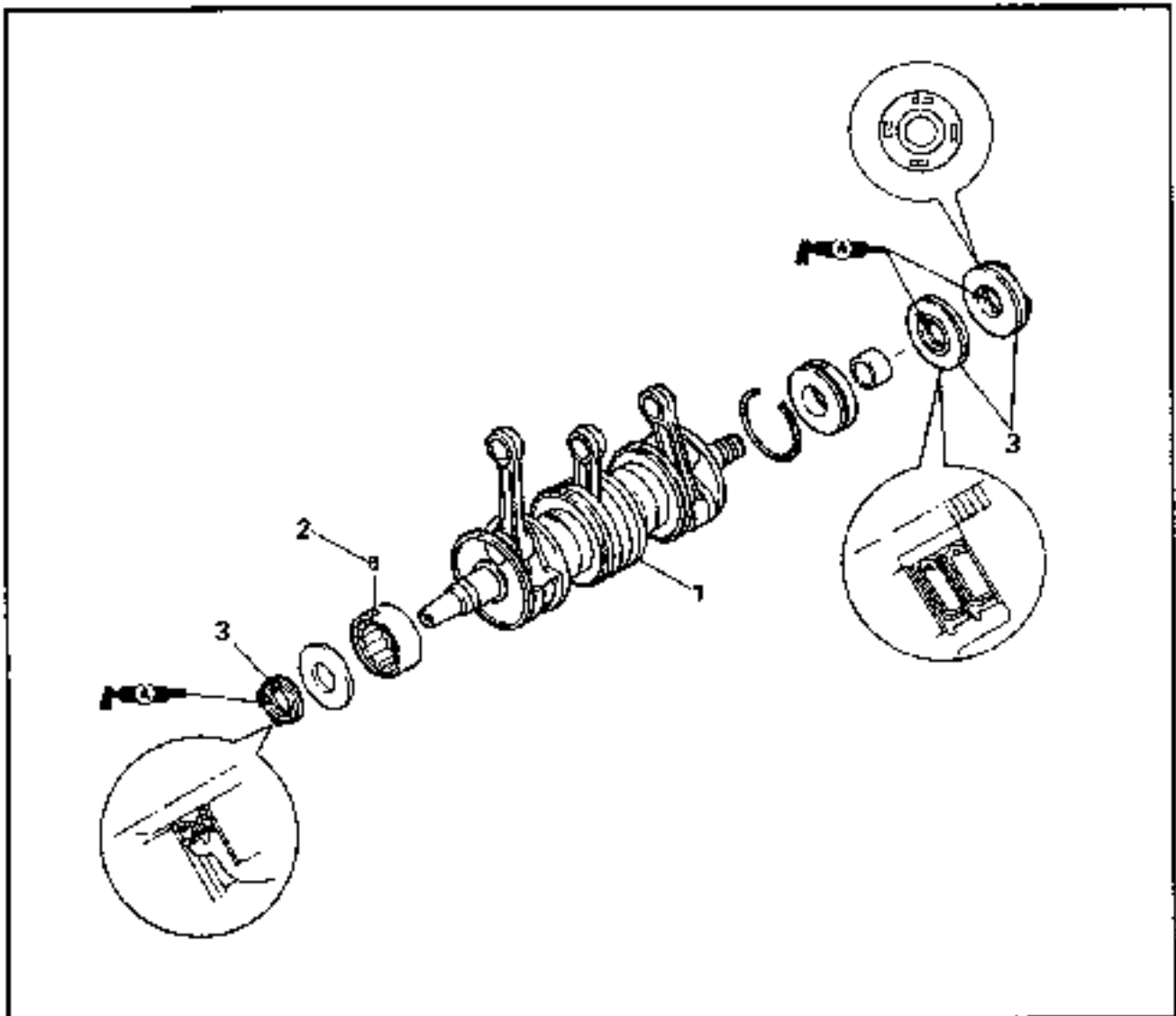

REMOVAL AND INSTALLATION CHART

Step	Procedure/Part name	Q'ty	Service points
1	<b>CRANKSHAFT REMOVAL</b> Crankcase Crankshaft assembly	1	Follow the left "Step" for removal. Refer to "CRANKCASE".  <ul style="list-style-type: none"> <li>Do not allow the bearing clip open ends to meet the crankcase contacting surface.</li> <li>Place the locating pins on the bearing into the crankcase body groove.</li> </ul>
2	Dowel pin	8	
3	Oil seal	3	
			Reverse the removal steps for installation.

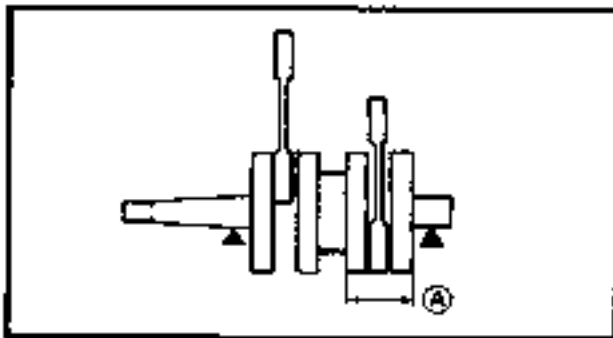

**SERVICE POINTS**

**Crankshaft inspection**

1. Measure:

- Crank width (A)  
Out of specification → Replace.



**Crank width:**  
61.95 - 62.00 mm  
(2.439 - 2.441 in)

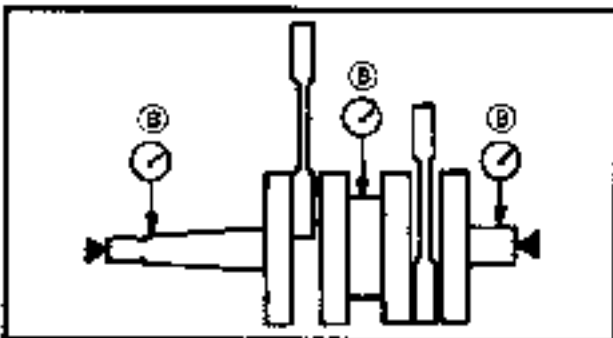

2. Measure:

- Deflection (B)  
Use a dial gauge.  
Out of specification → Replace.



**Maximum deflection:**  
0.05 mm (0.002 in)

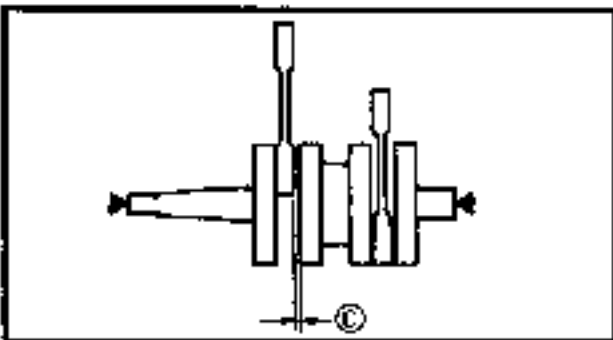

3. Measure:

- Big end and side clearance (C)  
Use a thickness gauge.  
Out of specification → Replace.



**Big end and side clearance:**  
0.25 - 0.75 mm  
(0.010 - 0.030 in)

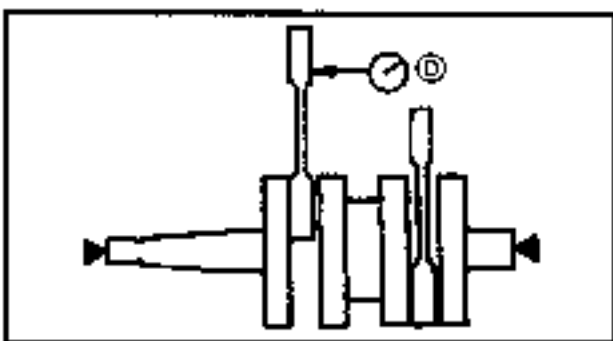

4. Measure:

- Small and free play (D)  
Use a dial gauge.  
Out of specification → Replace.



**Small and free play:**  
2.0 mm (0.08 in)

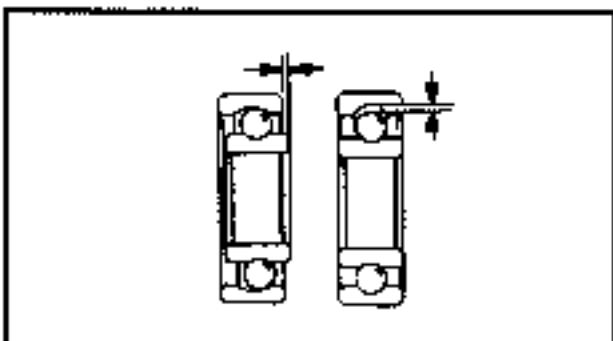

5. Inspect:

- Crankshaft bearing  
Pitting/Damage → Replace.

**NOTE:**

Lubricate the bearings immediately after examining them to prevent rusting.





## CRANKSHAFT

---

E

6. Inspect:
  - Crankshaft oil seal  
Wear/Damage → Replace.



**INTERMEDIATE HOUSING REMOVAL  
EXPLODED DIAGRAM**

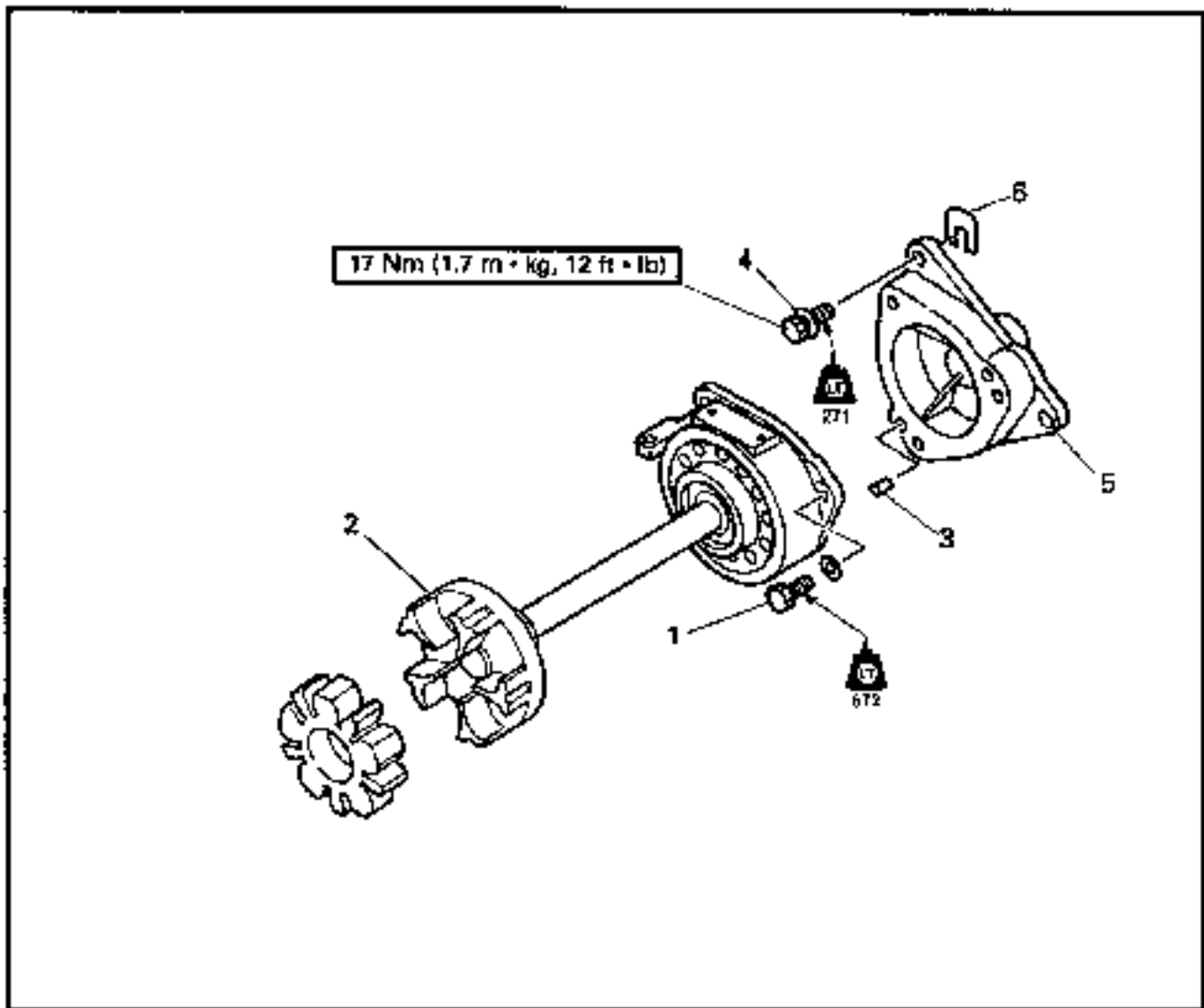

**REMOVAL AND INSTALLATION CHART**

Step	Procedure/Part name	Q'ty	Service points
	<b>INTERMEDIATE HOUSING REMOVAL</b>		Follow the left "Step" for removal.
	Engine unit		Refer to "ENGINE UNIT REMOVAL".
1	Bolt (with washer)	3	
2	Bearing housing assembly	1	
3	Pin	2	
4	Bolt (with washer)	3	
5	Housing	1	
6	Shim	*	
			<b>NOTE:</b> _____ Install the previously marked shims back into their original location. _____
			Reverse the removal steps for installation.

\*: As required



**INTERMEDIATE HOUSING  
EXPLODED DIAGRAM**

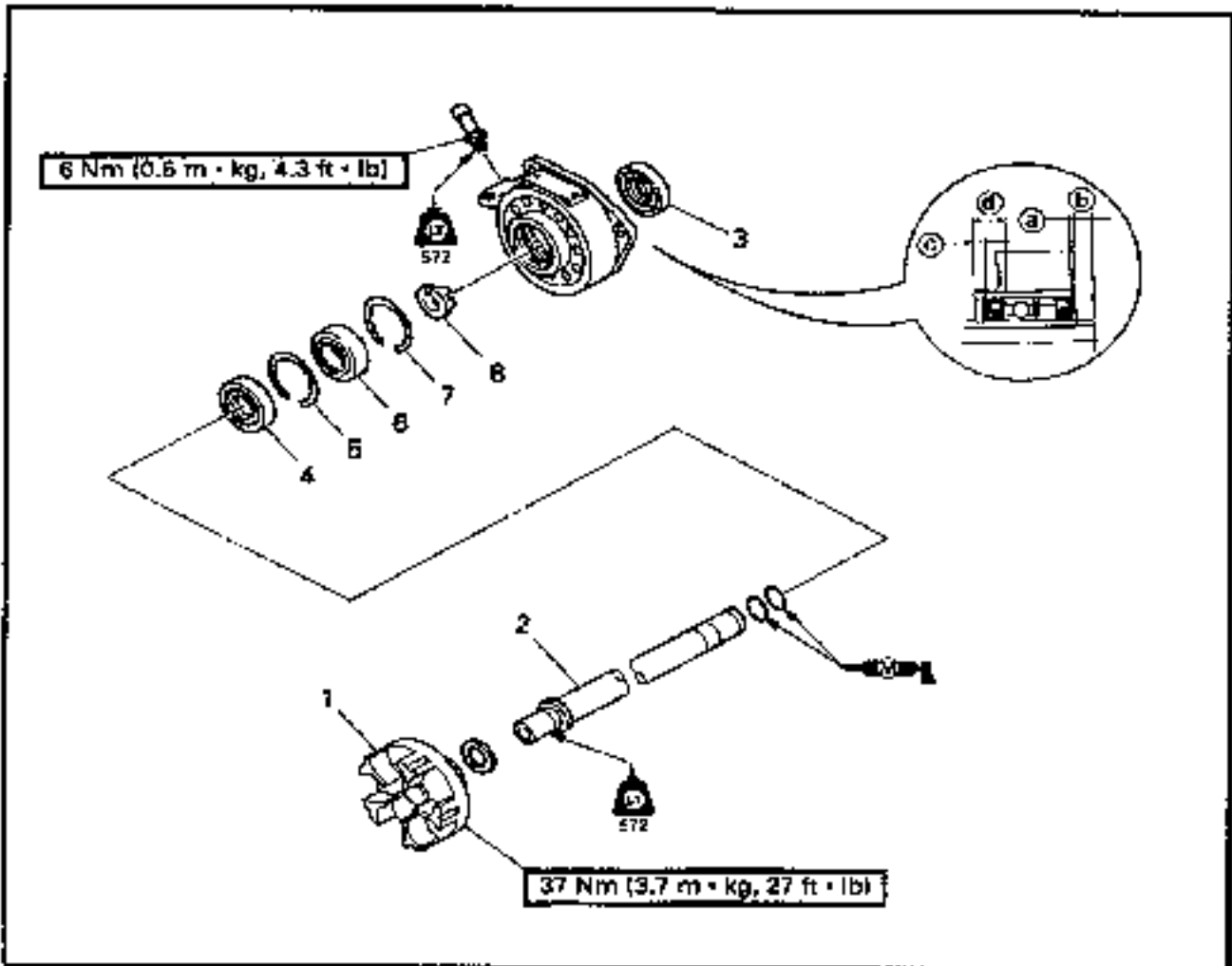

**REMOVAL AND INSTALLATION CHART**

Step	Procedure/Part name	Q'ty	Service points
	<b>INTERMEDIATE HOUSING DISASSEMBLY</b> Bearing housing assembly		Follow the left "Step" for removal.  Refer to "INTERMEDIATE HOUSING RE- MOVAL".
1	Coupling	1	 <b>Distance:</b> Ⓐ: 1.6 - 2.0 mm (0.06 - 0.08 in) Ⓑ: 14.5 - 15.5 mm *1 (0.57 - 0.61 in) 9.5 - 10.5 mm *1 (0.37 - 0.41 in) Ⓒ: 6.8 - 7.2 mm (0.27 - 0.28 in) Ⓓ: 17.6 - 17.7 mm (0.69 - 0.70 in)
2	Shaft	1	
3	Oil seal	1	
4	Oil seal	1	
5	Clip	1	
6	Bearing	1	
7	Clip	1	
8	Spacer	1	
			Reverse the removal steps for installation.

\*1: GP760

\*2: GP1200

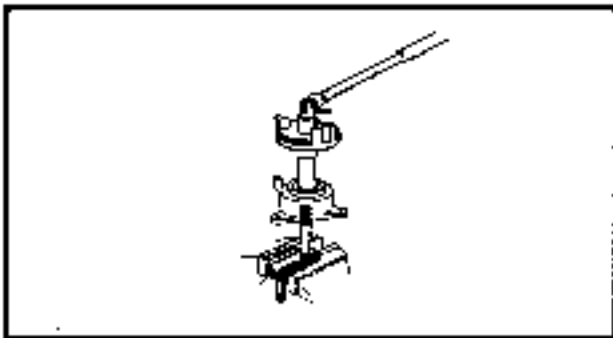
**SERVICE POINTS****Coupling removal and installation**

1. Remove and install:
  - Coupling



Coupler wrench:

YW-06546/90890-06546

Shaft holder:

YW-38742/90890-08069

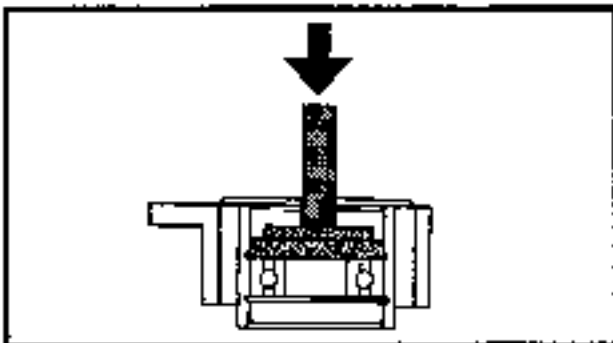
**Bearing removal and installation**

1. Remove and install:
  - Bearing



Driver rod:

YB-06071/90890-06606

Bearing outer race attachment:

YB-06016/90890-06626

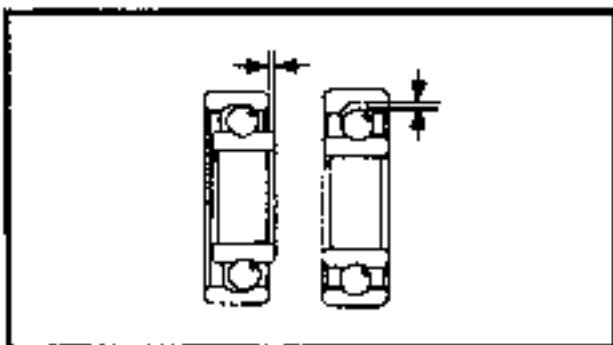
**Bearing inspection**

1. Inspect:
  - Bearing
    - Rotate inner race by hand.
    - Rough spots/Seizure → Replace.
  - Shaft
    - Pitting/Damage → Replace.
  - Hose
    - Wear/Cracks → Replace.

**Coupling Inspection**

1. Inspect:
  - Coupling flange
  - Coupling rubber
    - Wear/Damage → Replace.

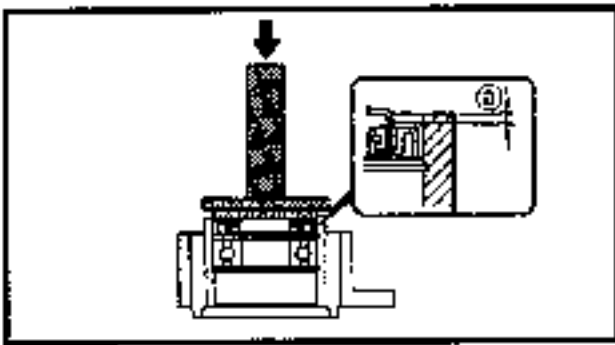

**Oil seal installation**

1. Install:

- Oil seal [T = 8 mm (0.31 in)]



**Distance a):**  
6.8 - 7.2 mm (0.27 - 0.28 in)



**Driver rod:**  
YB-06071/90890-06606  
**Bearing outer race attachment:**  
YB-06016/90890-06626

**NOTE:**

Fill the water resistant grease on the clip inner circumference before installing the oil seal.

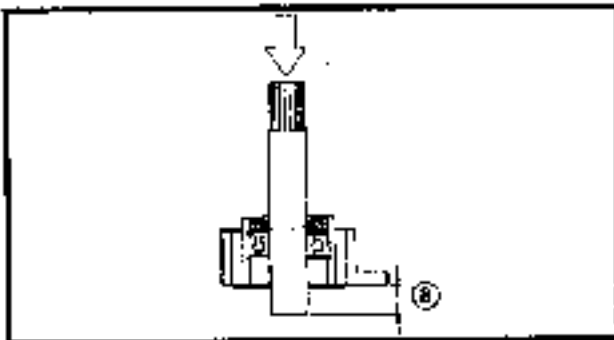

2. Install:

- Shaft



**Distance a):**  
GP780  
14.5 - 15.5 mm (0.57 - 0.61 in)  
GP1200  
9.5 - 10.5 mm (0.37 - 0.41 in)

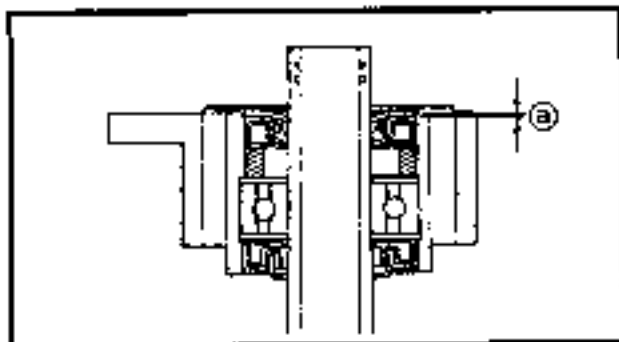

3. Install:

- Oil seal [T = 10 mm (0.38 in)]



**Distance a):**  
1.6 - 2.0 mm (0.06 - 0.08 in)

**NOTE:**

Fill the water resistant grease on the clip and spacer inner circumference before installing the oil seal.

**CHAPTER 6  
JET PUMP UNIT**

<b>JET PUMP UNIT REMOVAL</b> .....	6 - 1
EXPLODED DIAGRAM .....	6 - 1
REMOVAL AND INSTALLATION CHART .....	6 - 1
 <b>DEFLECTOR AND TRIM RING</b> .....	6 - 2
EXPLODED DIAGRAM .....	6 - 2
REMOVAL AND INSTALLATION CHART .....	6 - 2
 <b>NOZZLE, DUCT AND INTAKE</b> .....	6 - 3
EXPLODED DIAGRAM .....	6 - 3
REMOVAL AND INSTALLATION CHART .....	6 - 3
SERVICE POINTS .....	6 - 4
Housing inspection .....	6 - 4
 <b>IMPELLER AND DRIVE SHAFT</b> .....	6 - 5
EXPLODED DIAGRAM .....	6 - 5
REMOVAL AND INSTALLATION CHART .....	6 - 5
SERVICE POINTS .....	6 - 6
Drive shaft removal .....	6 - 6
Impeller inspection .....	6 - 6
Drive shaft inspection .....	6 - 6
Bearing inspection .....	6 - 6
Drive shaft installation .....	6 - 7
 <b>INTAKE DUCT</b> .....	6 - 8
EXPLODED DIAGRAM .....	6 - 8
REMOVAL AND INSTALLATION CHART .....	6 - 8
SERVICE POINTS .....	6 - 9
Oil seal and bushing removal .....	6 - 9
Housing inspection .....	6 - 9
Seal rubber inspection .....	6 - 9
Bushing and oil seal installation .....	6 - 9
 <b>COOLING AND BILGE SYSTEM</b> .....	6 - 10
EXPLODED DIAGRAM .....	6 - 10
REMOVAL AND INSTALLATION CHART .....	6 - 10
SERVICE POINTS .....	6 - 10
Bilge strainer inspection .....	6 - 10
Hose inspection .....	6 - 10

**JET PUMP UNIT REMOVAL  
EXPLODED DIAGRAM**

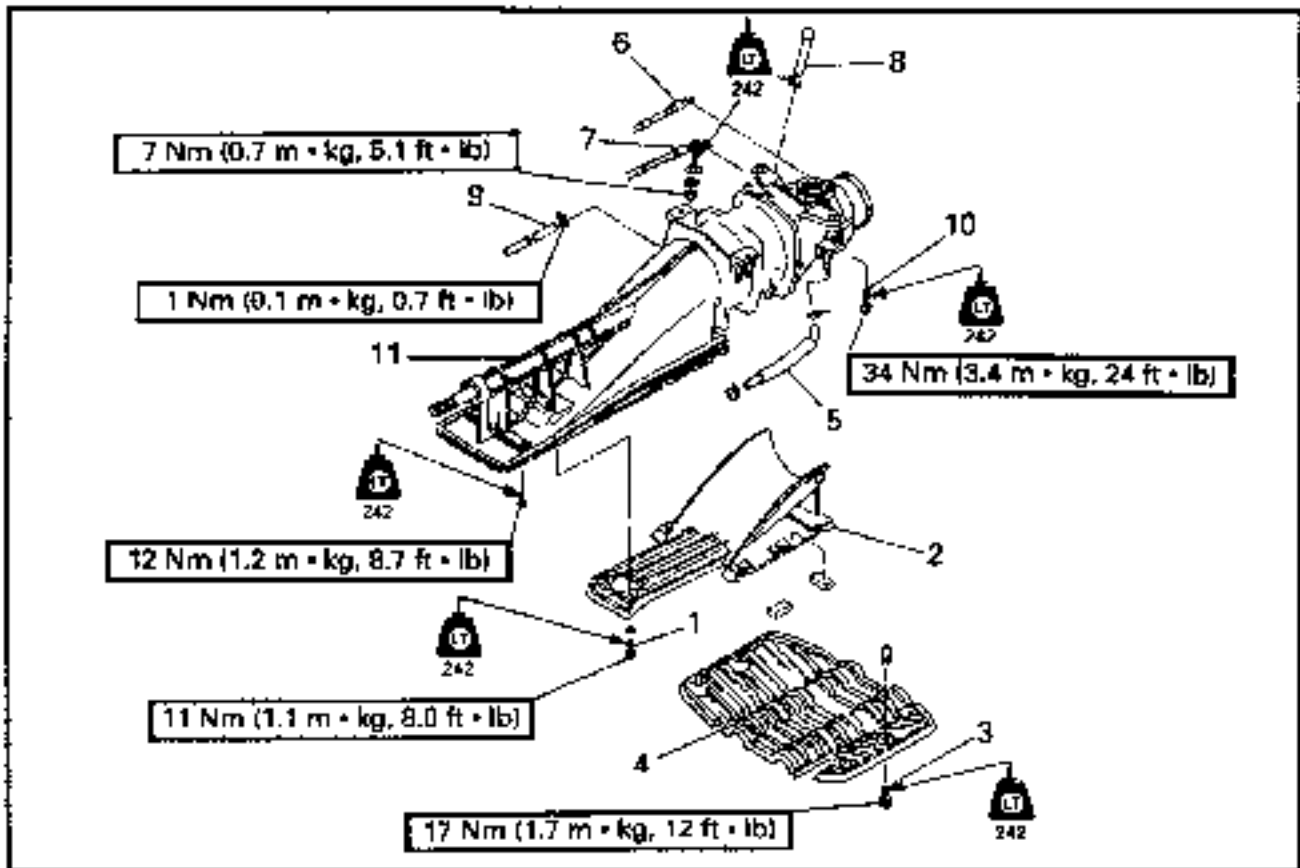

**REMOVAL AND INSTALLATION CHART**

Step	Procedure/Part name	Q'ty	Service points
<b>JET PUMP UNIT REMOVAL</b>			Follow the left "Step" for removal.  8 x 30 mm  <b>NOTE:</b> ● Pull the jet pump unit straight backward. ● When installing the jet pump unit, align the drive shaft spline (male) with the intermediate shaft spline (female).  Reverse the removal steps for installation.
1	Bolt (with washer)	6, 8	
2	Intake screen	1	
3	Bolt (with washer)	4	
4	Ride plate	1	
5	Bilge hose	1	
6	Trim cable joint	1	
7	Steering cable joint	1	
8	Spout hose	1	
9	Engine cooling hose	1	
10	Bolt (with washer)	4	
11	Jet pump unit	1	

**DEFLECTOR AND TRIM RING  
EXPLODED DIAGRAM**

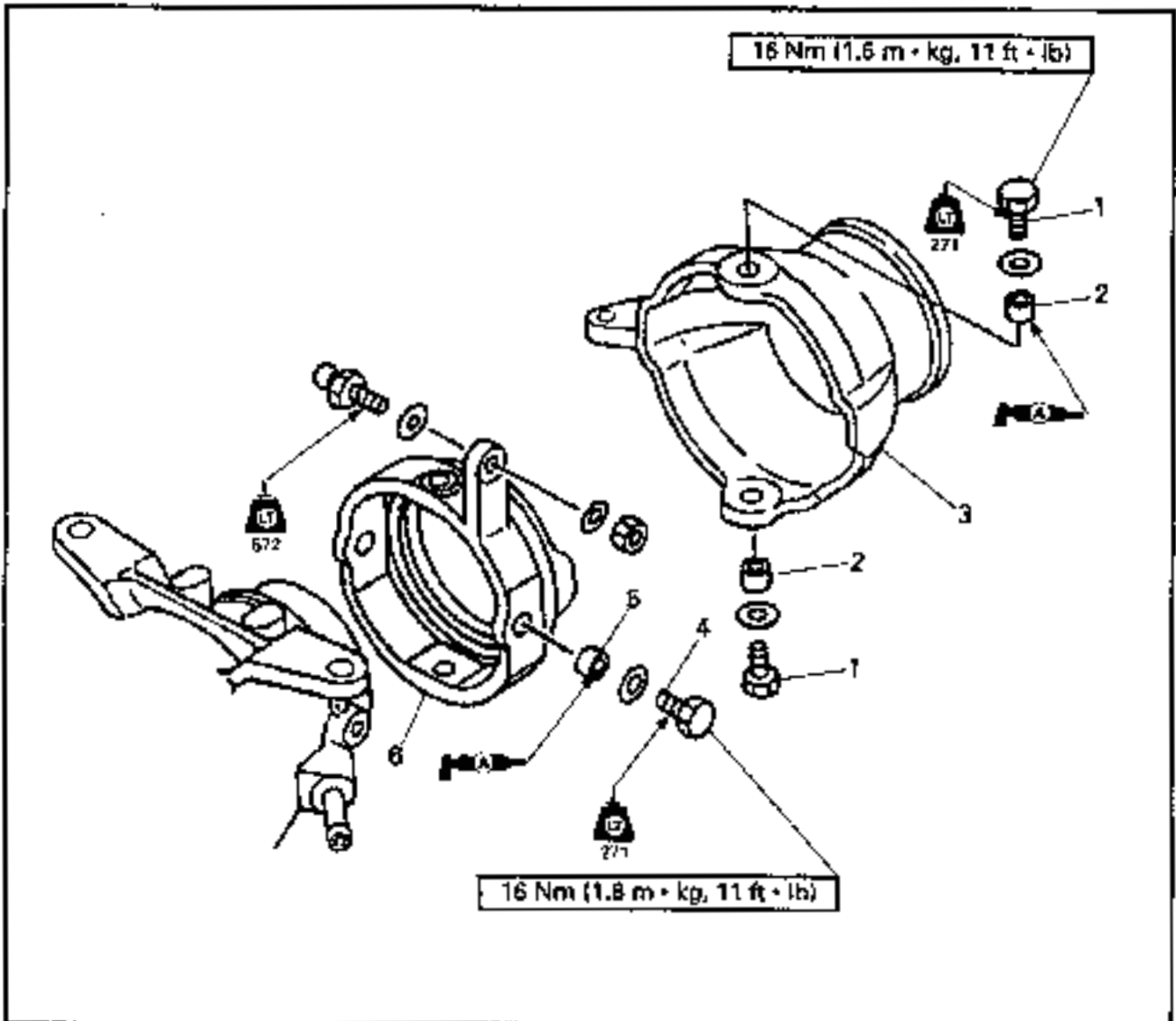

**REMOVAL AND INSTALLATION CHART**

Step	Procedure/Part name	Qty	Service points
	<b>DEFLECTOR AND TRIM RING REMOVAL</b>		Follow the left "Step" for removal.
	Jet pump unit		Refer to the "JET PUMP UNIT REMOVAL".
1	Bolt (with washer)	2	8 x 20 mm
2	Collar	2	
3	Nozzle deflector	1	
4	Bolt (with washer)	2	8 x 20 mm
5	Collar	2	
6	Trim ring	1	
			Reverse the removal steps for installation.





**NOZZLE, DUCT AND INTAKE  
EXPLODED DIAGRAM**

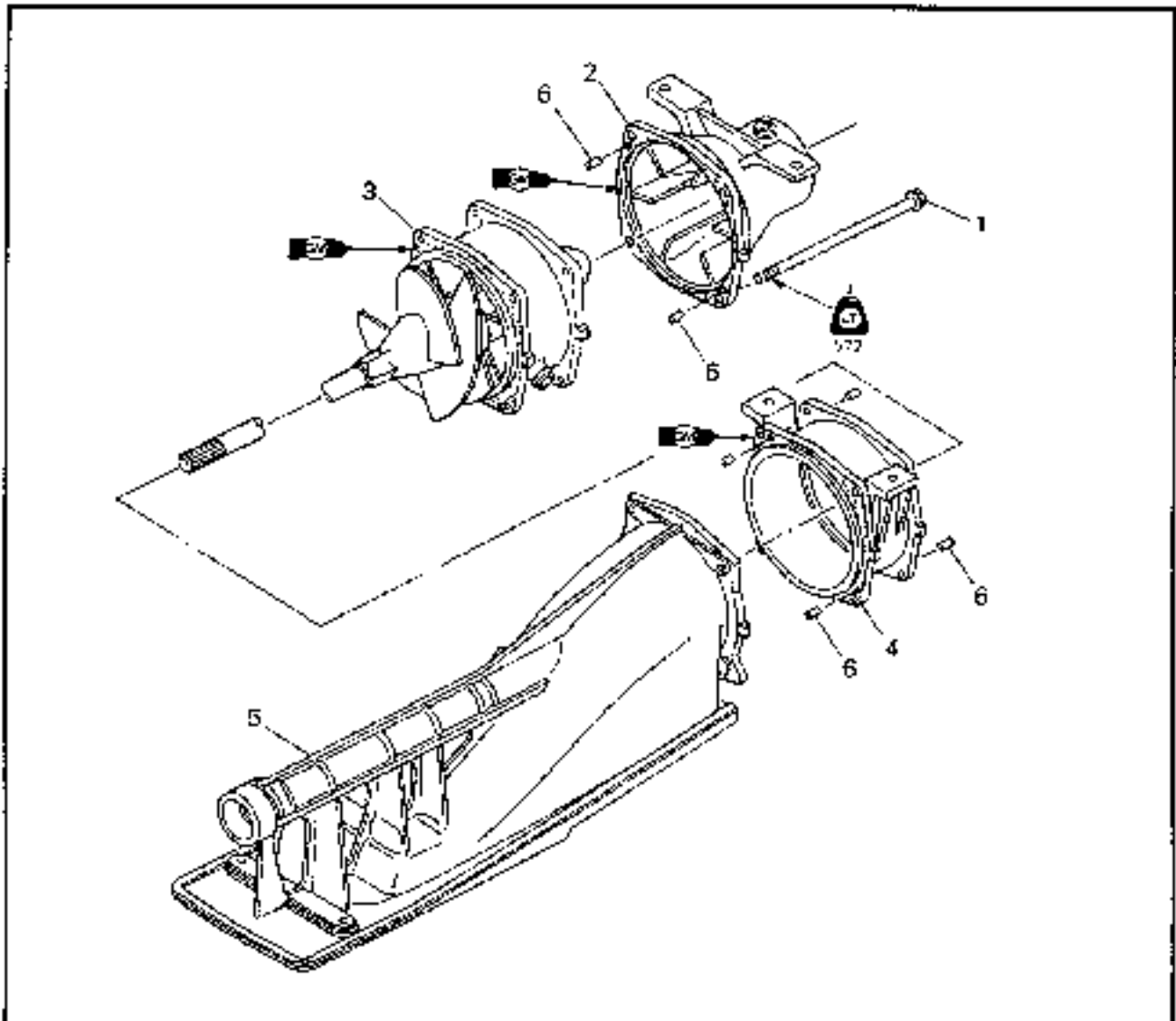

**REMOVAL AND INSTALLATION CHART**

Step	Procedure/Part name	Q'ty	Service points
	<b>NOZZLE, DUCT AND INTAKE REMOVAL</b>		Follow the left "Step" for removal.
	Trim ring		Refer to "DEFLECTOR AND TRIM RING" section.
1	Bolt	4	<b>NOTE:</b> _____ Clean the contacting surfaces before applying the Gasket Marker.
2	Nozzle	1	
3	Impeller duct assembly	1	
4	Housing	1	
5	Intake duct assembly	1	Reverse the removal steps for installation.
6	Pin	6	

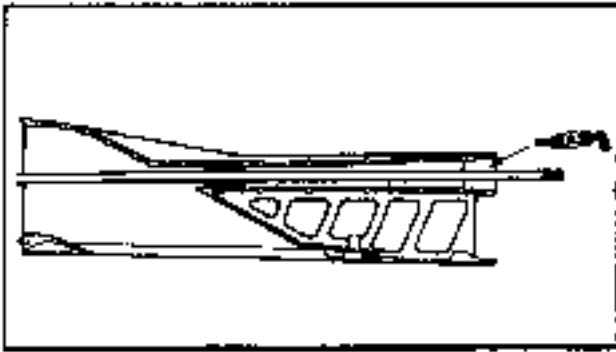
**SERVICE POINTS****Housing installation**

1. Fill:

- Intake duct housing

**Water resistant grease:**  
130 - 170 cm<sup>3</sup> (7.8 - 10.4 cu. in)



**IMPELLER AND DRIVE SHAFT  
EXPLODED DIAGRAM**

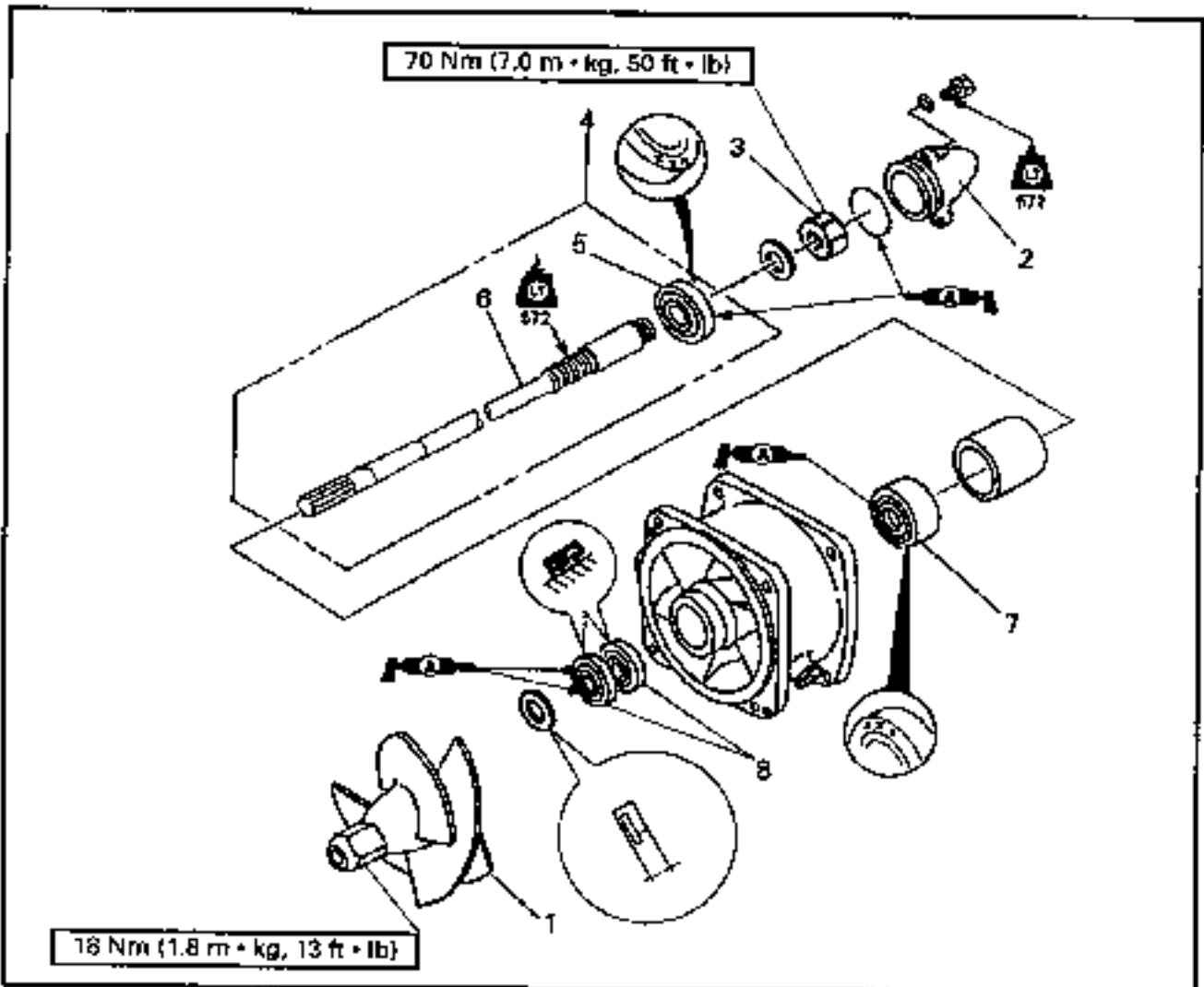

**REMOVAL AND INSTALLATION CHART**

Step	Procedure/Part name	Qty	Service points
	<b>IMPELLER AND DRIVE SHAFT DISASSEMBLY</b>		Follow the left "Step" for removal
	Impeller duct assembly		Refer to "DEFLECTOR, NOZZLE AND DUCT".
1	Impeller	1	
2	Cap	1	
3	Nut	1	
4	Drive shaft assembly	1	
5	Bearing (rear)	1	
6	Drive shaft	1	
7	Bearing (front)	1	
8	Oil seal	2	Reverse the removal steps for installation.

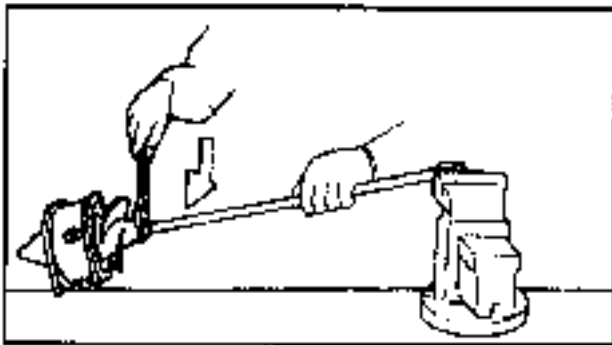

**SERVICE POINTS**

**Drive shaft removal**

1. Remove:
  - Impeller



**Drive shaft holder:**  
YB-06049/90890-06518

**NOTE:**

The impeller has a left-hand thread. Turn the impeller clockwise to loosen it.

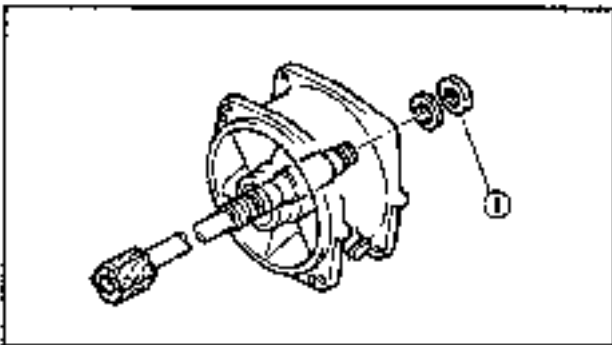

2. Remove:
  - Nut ①



**Drive shaft holder:**  
YB-06049/90890-06518

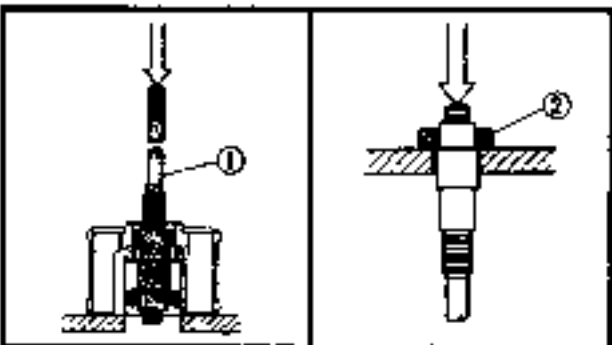

3. Remove:
  - Drive shaft and bearing (rear) ①
  - Bearing (rear) ②

**NOTE:**

Use a press.

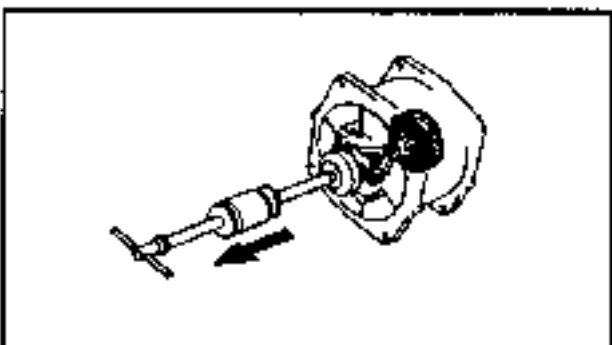

4. Remove:
  - Bearing (front)



**Slide hammer set:**  
90890-06523  
YB-06096/90890-06531

**Impeller inspection**

Refer to "JET PUMP UNIT" in chapter 3.

**Drive shaft inspection**

1. Inspect:
  - Drive shaft
  - Wear/Damage → Replace.

**Bearing inspection**

1. Inspect:
  - Bearing (front and rear)
  - Rotate inner race by hand.
  - Rough spot/Seizure → Replace.

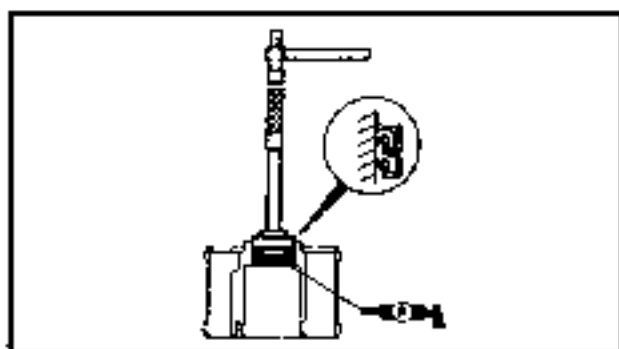

**Drive shaft installation**

1. Install:
  - Oil seal



**Driver rod:**  
YB-06071/90890-06606  
**Ball bearing attachment:**  
YB-06156/90890-06634

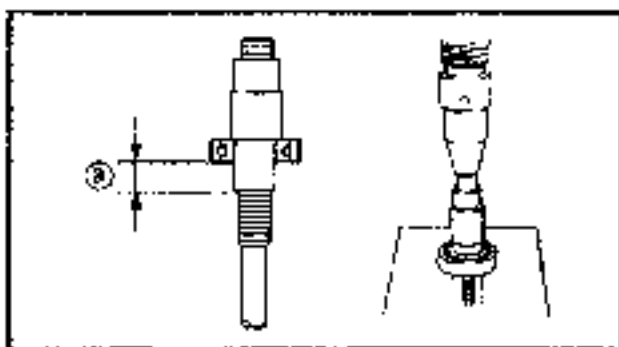

2. Install:
  - Bearing (front)
  - Drive shaft and bearing



**Distance ② :**  
 $23 \pm 0.1 \text{ mm}$  ( $0.91 \pm 0.004 \text{ in}$ )

**NOTE:**

Use a press.

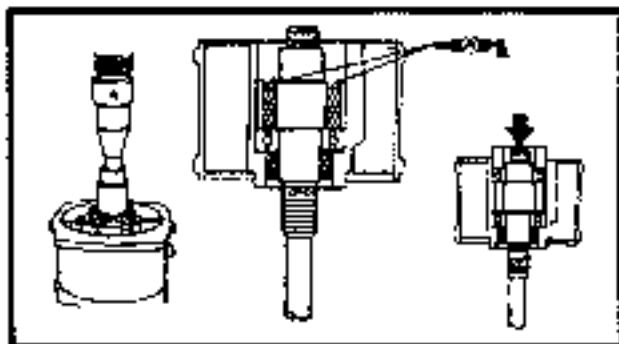

3. Fill:
  - Between the drive shaft and spacer



**Water resistant grease:**  
 $13 \text{ cm}^3$  ( $0.8 \text{ cu. in}$ )

4. Install:
  - Bearing (rear)



**Bearing Inner race attachment:**  
YB-34474/90890-06662

5. Fill:
  - Into the cap



**Water resistant grease:**  
 $18 \text{ cm}^3$  ( $1.1 \text{ cu. in}$ )

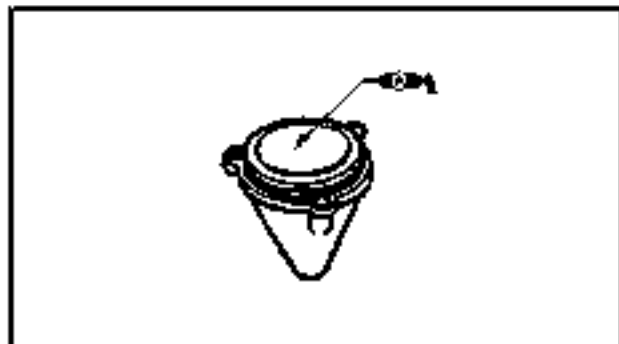

6. Install:
  - Nut
  - Impeller



**Drive shaft holder:**  
YB-06049/90890-06518

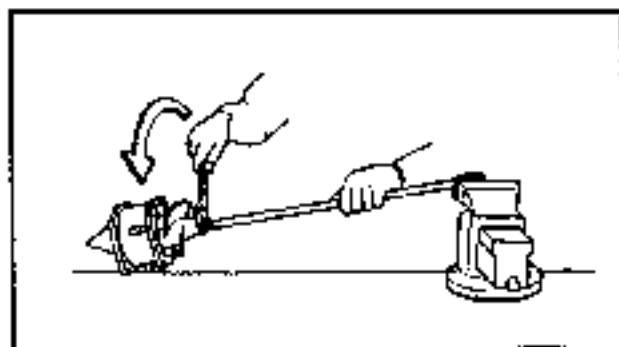

**INTAKE DUCT  
EXPLODED DIAGRAM**

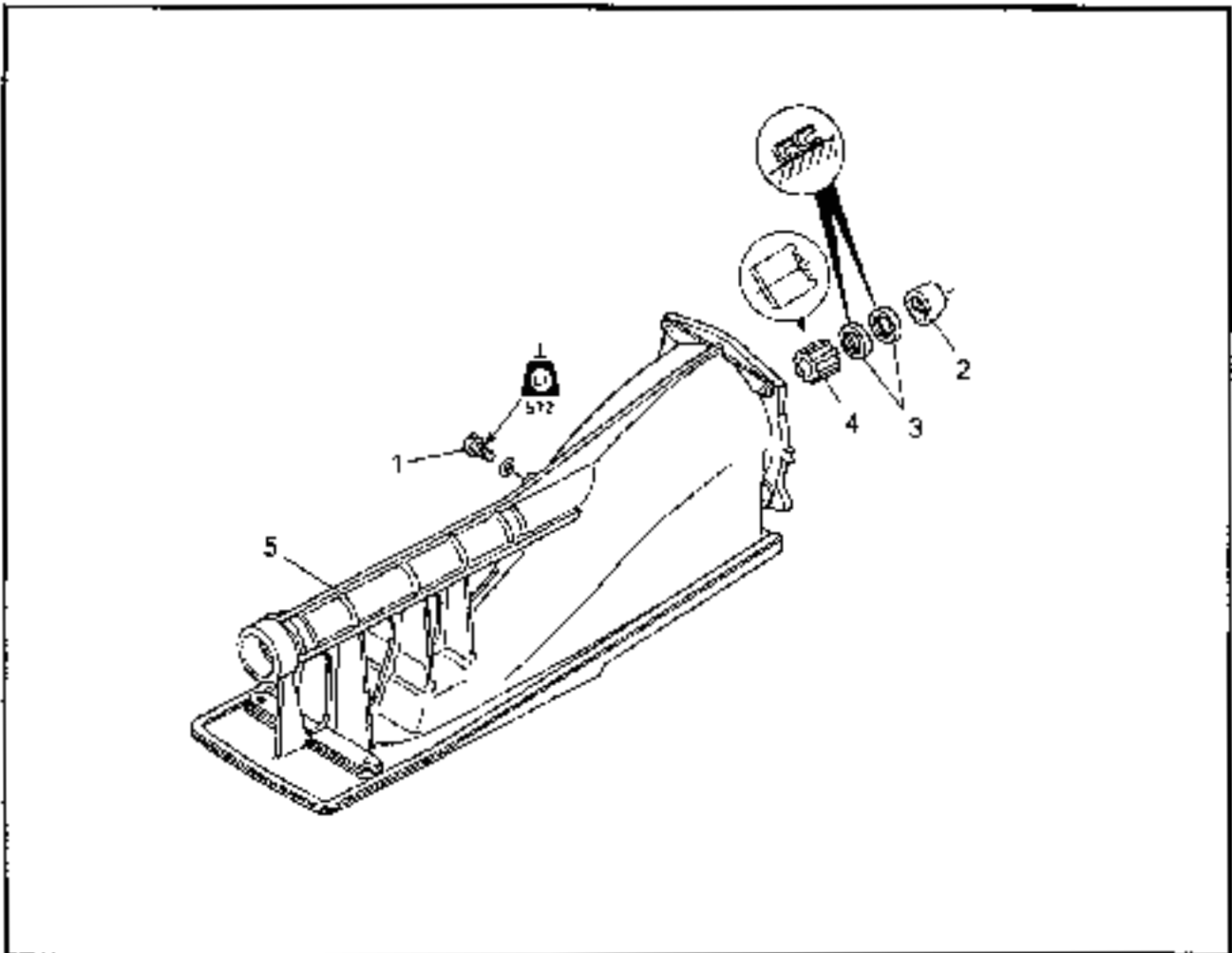

**REMOVAL AND INSTALLATION CHART**

Step	Procedure/Part name	Q'ty	Service points
	<b>INTAKE DUCT DISASSEMBLY</b>		
	Intake duct assembly		Follow the left "Step" for removal. Refer to "NOZZLE, DUCT AND INTAKE".
1	Bolt (with washer)	1	
2	Spacer	1	
3	Oil seal	2	
4	Bushing	1	
5	Intake duct	1	
			Reverse the removal steps for installation.

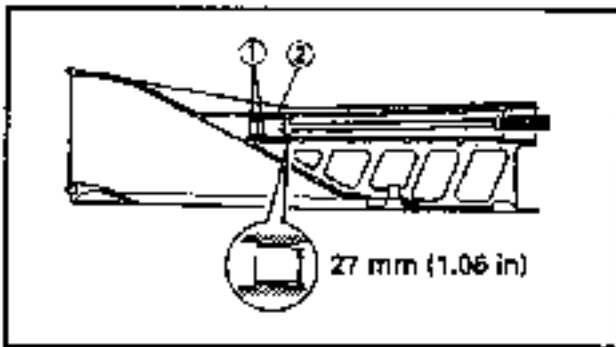

**SERVICE POINTS**

**Oil seal and bushing removal**

1. Remove:
  - Oil seal (1)
  - Bushing (2)

	<b>Driver rod:</b>
	YB-06229/90890-06605
	<b>Ball bearing attachment:</b> YB-06021/90890-06638

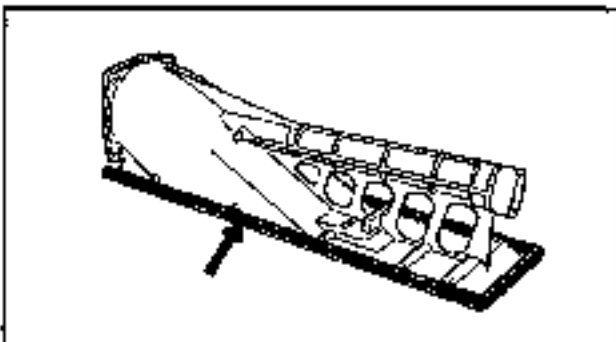

**Housing inspection**

1. Inspect:
  - Housing inner surface
  - Wear/Damage → Replace.

**Seal rubber inspection**

1. Inspect:
  - Seal rubber
  - Crack/Wear → Replace.

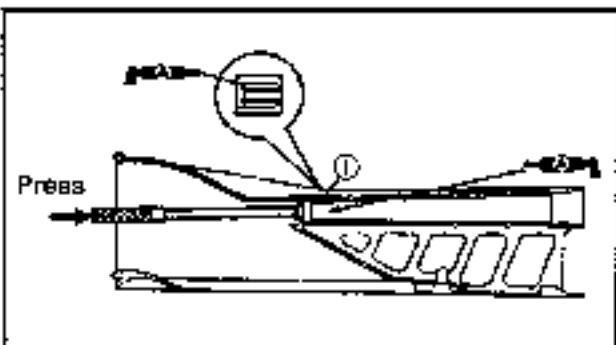

**Bushing and oil seal installation**

1. Install:
  - Bushing (1)

	<b>Driver rod:</b>
	YB-06071/90890-06602
	<b>Needle bearing attachment:</b> YB-06155/90890-06611

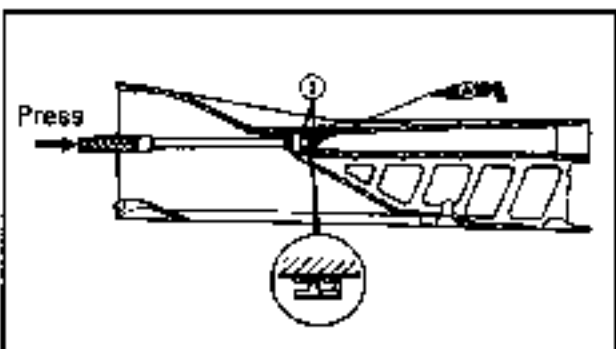

2. Install:
  - Oil seal (1)

	<b>Driver rod:</b>
	YB-06071/90890-06602
	<b>Needle bearing attachment:</b> YB-06155/90890-06611

**COOLING AND BILGE SYSTEM  
EXPLODED DIAGRAM**

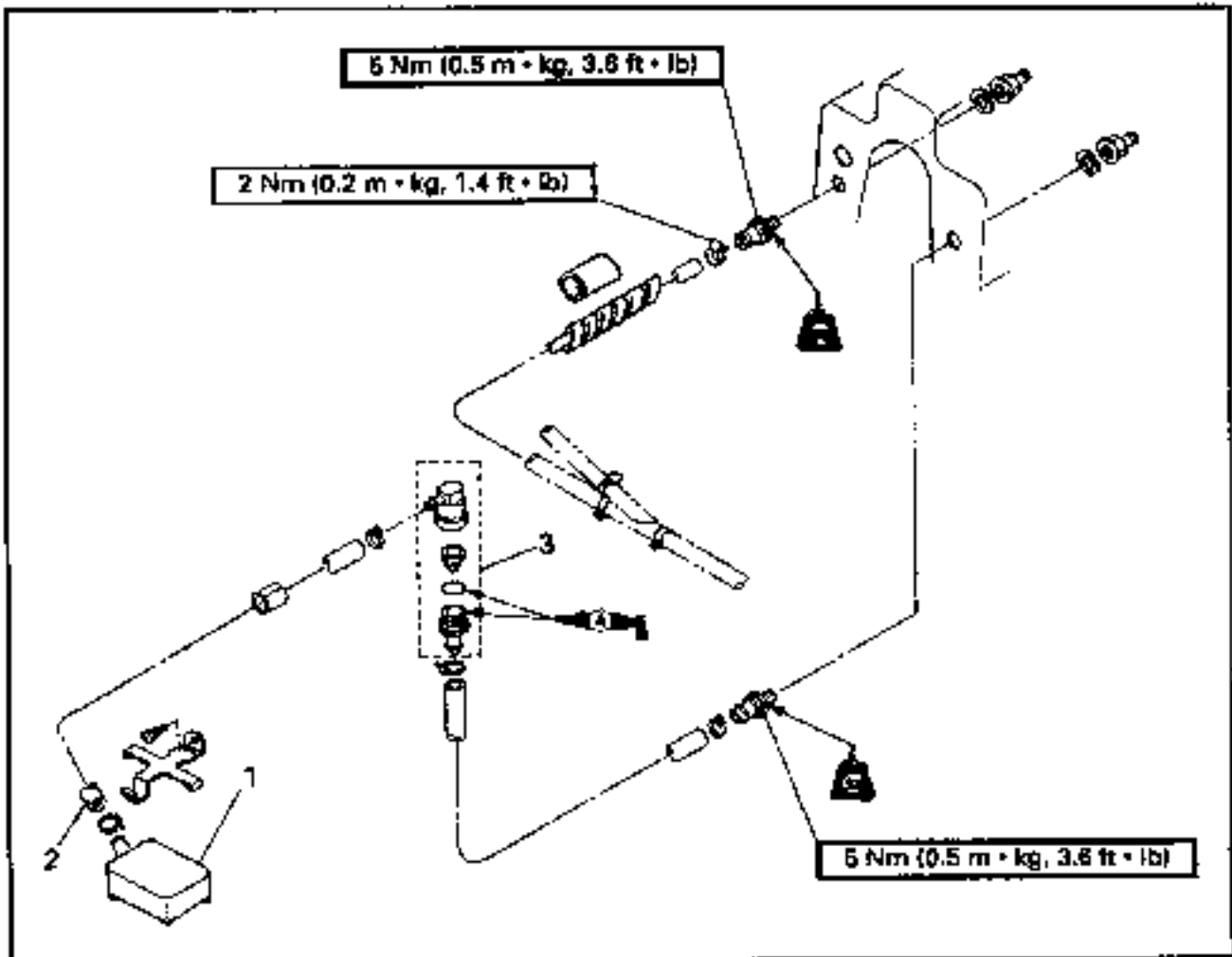

**REMOVAL AND INSTALLATION CHART**

Step	Procedure/Part name	Q'ty	Service points
<b>COOLING AND BILGE SYSTEM REMOVAL</b>			Follow the left "Step" for removal.
1	Bilge strainer	1	
2	Bilge hose	1	
3	Hose joint	1	Reverse the removal steps for installation.

**SERVICE POINTS**

**Bilge strainer inspection**  
Refer to "JET PUMP UNIT" in chapter 3.

**Hose inspection**

1. Inspect:
  - Hose  
Crack/Wear/Damage → Replace.





## CHAPTER 7 ELECTRICAL SYSTEM

<b>ELECTRICAL COMPONENTS</b> .....	7 - 1
GP760 .....	7 - 1
GP1200 .....	7 - 2
<b>SERVICE POINTS</b> .....	7 - 3
Spiral tube installation .....	7 - 3
 <b>ELECTRICAL UNIT</b> .....	 7 - 4
GP760 .....	7 - 4
GP1200 .....	7 - 5
 <b>ELECTRICAL ANALYSIS</b> .....	 7 - 6
<b>INSPECTION</b> .....	7 - 6
Low resistance measurement .....	7 - 6
 <b>IGNITION SYSTEM</b> .....	 7 - 7
<b>WIRING DIAGRAM</b> .....	7 - 7
GP760 .....	7 - 7
GP1200 .....	7 - 8
<b>IGNITION SPARK GAP</b> .....	7 - 9
<b>SPARK PLUG</b> .....	7 - 10
<b>SPARK PLUG CAP</b> .....	7 - 10
<b>IGNITION COIL</b> .....	7 - 10
<b>ENGINE STOP SWITCH</b> .....	7 - 11
<b>CHARGE COIL</b> .....	7 - 11
<b>PULSER COIL</b> .....	7 - 12
<b>THERMO SWITCH</b> .....	7 - 12
<b>CDI UNIT</b> .....	7 - 13
 <b>STARTING SYSTEM</b> .....	 7 - 14
<b>WIRING DIAGRAM</b> .....	7 - 14
<b>BATTERY</b> .....	7 - 15
<b>STARTER MOTOR</b> .....	7 - 15
<b>WIRING CONNECTION</b> .....	7 - 15
<b>FUSE</b> .....	7 - 15
<b>STARTER SWITCH</b> .....	7 - 15
<b>STARTER RELAY</b> .....	7 - 15
 <b>CHARGING SYSTEM</b> .....	 7 - 17
<b>WIRING DIAGRAM</b> .....	7 - 17
<b>FUSE</b> .....	7 - 18
<b>BATTERY</b> .....	7 - 18
<b>LIGHTING COIL</b> .....	7 - 18
<b>RECTIFIER REGULATOR</b> .....	7 - 18

---

<b>INDICATION SYSTEM</b> .....	7 - 19
<b>WIRING DIAGRAM</b> .....	7 - 19
<b>OIL LEVEL SENSOR</b> .....	7 - 20
<b>FUEL LEVEL SENSOR</b> .....	7 - 20
<b>FUSE</b> .....	7 - 20
<b>BATTERY</b> .....	7 - 20
<b>LIGHTING COIL</b> .....	7 - 20
<b>MULTI FUNCTION-METER</b> .....	7 - 21
Instrument indicating function .....	7 - 21
Security function .....	7 - 22



## ELECTRICAL COMPONENTS

GP760

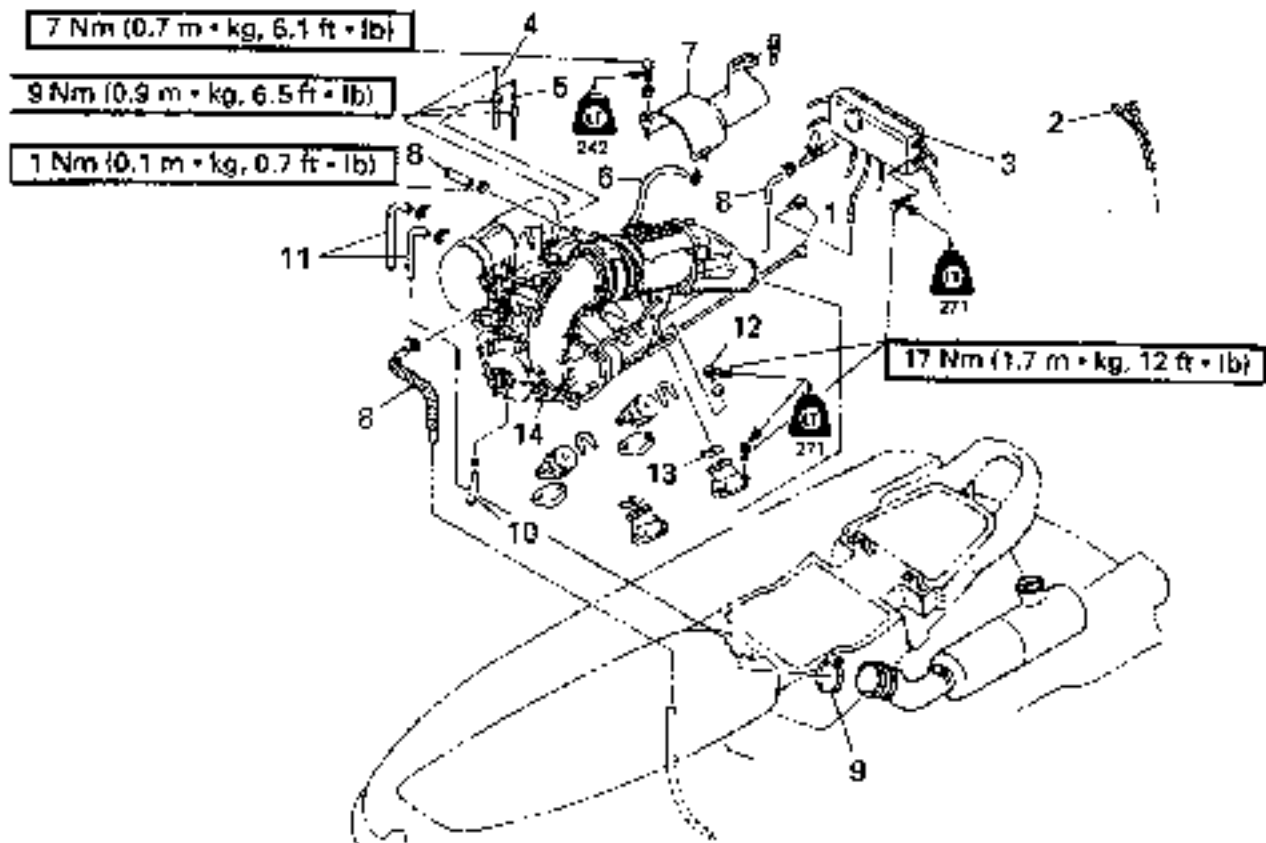

- 1) Fuel level sensor lead
- 2) Oil level sensor lead
- 3) #1 High tension cord
- 4) #2 High tension cord
- 5) Battery (negative) lead
- 6) Battery (positive) lead
- 7) Speed sensor lead
- 8) Electrical box lead

- 9) Thermo sensor lead
- 10) Starter motor (positive) lead
- 11) Flywheel magneto base lead



## GP1200

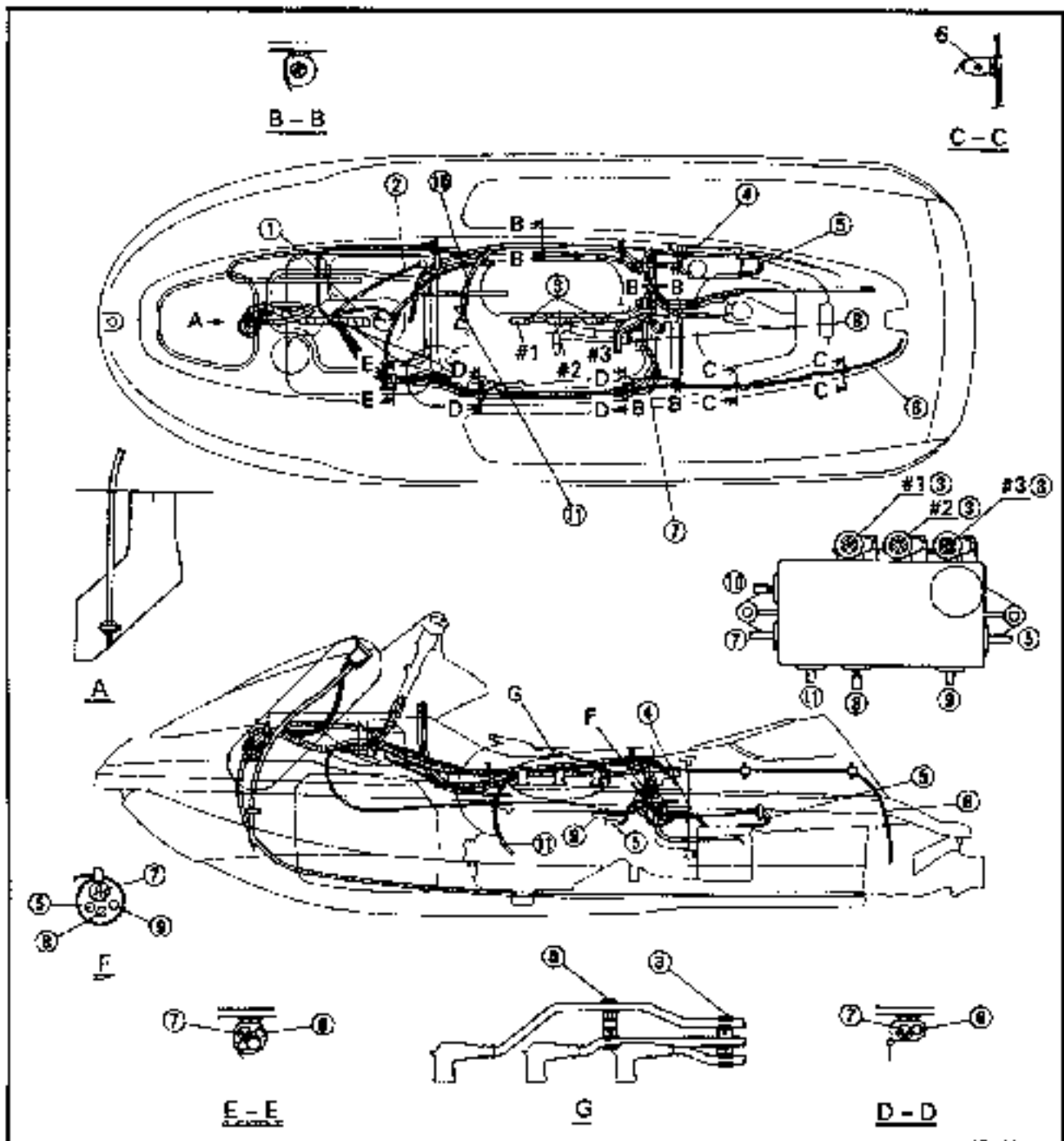

- ① Fuel level sensor lead
- ② Oil level sensor lead
- ③ High tension cord
- ④ Battery (negative) lead
- ⑤ Battery (positive) lead
- ⑥ Speed sensor lead
- ⑦ Electrical box lead
- ⑧ Thermo sensor lead
- ⑨ Starter motor (positive) lead
- ⑩ Pulsar coil lead

⑪ Flywheel magneto base lead

**NOTE:**

First, install clamps ③ on the white marks of the #1 cylinder high tension cord, then the plug caps to the spark plugs, and secure the #2 and #3 cylinder high tension cords with the clamps.

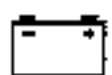

760

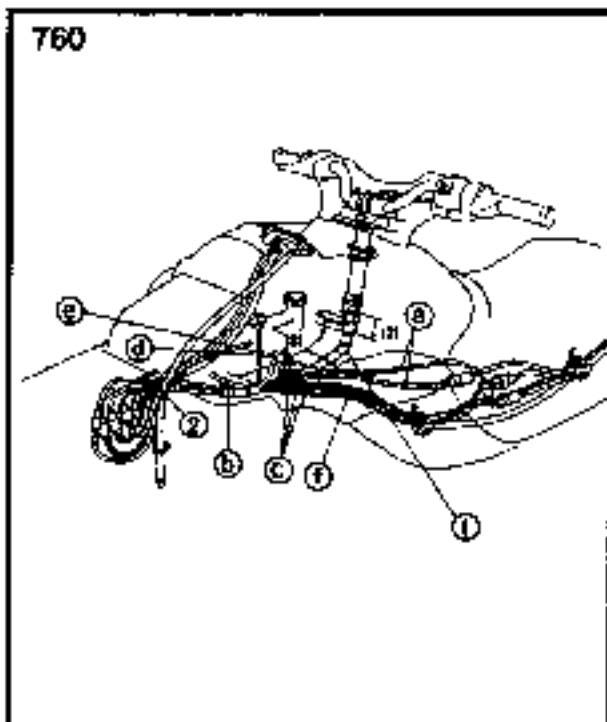

120D

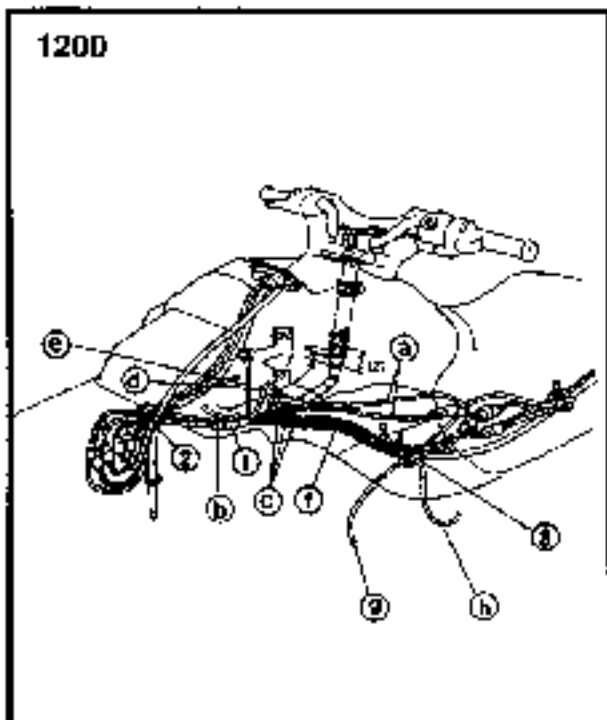
**SERVICE POINTS****Spiral tube installation**

1. Install:
  - Spiral tube 2 (1)

**NOTE:**

- Give 10 windings of the spiral tube to the throttle cable, handle switch leads and buzzer lead and slide the spiral tube into the steering shaft by 2 windings.
- Secondly, except for the handle switch leads (a) and throttle cable (b), include the electrical box leads (c), fuel sensor lead (d), oil sensor lead (e) and speed sensor lead (f).
- Finally, continue wiring (buzzer lead, electrical box leads, fuel sensor lead, oil sensor lead and speed sensor lead) all through the rest of the spiral tube.
- Clamp the leads with the band (2).

2. Install: GP1200

- Band (3).

**NOTE:**

Clamp the leads, water pilot hose (g) and air ventilation hose (h) with band.

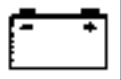

## ELECTRICAL UNIT

GP760

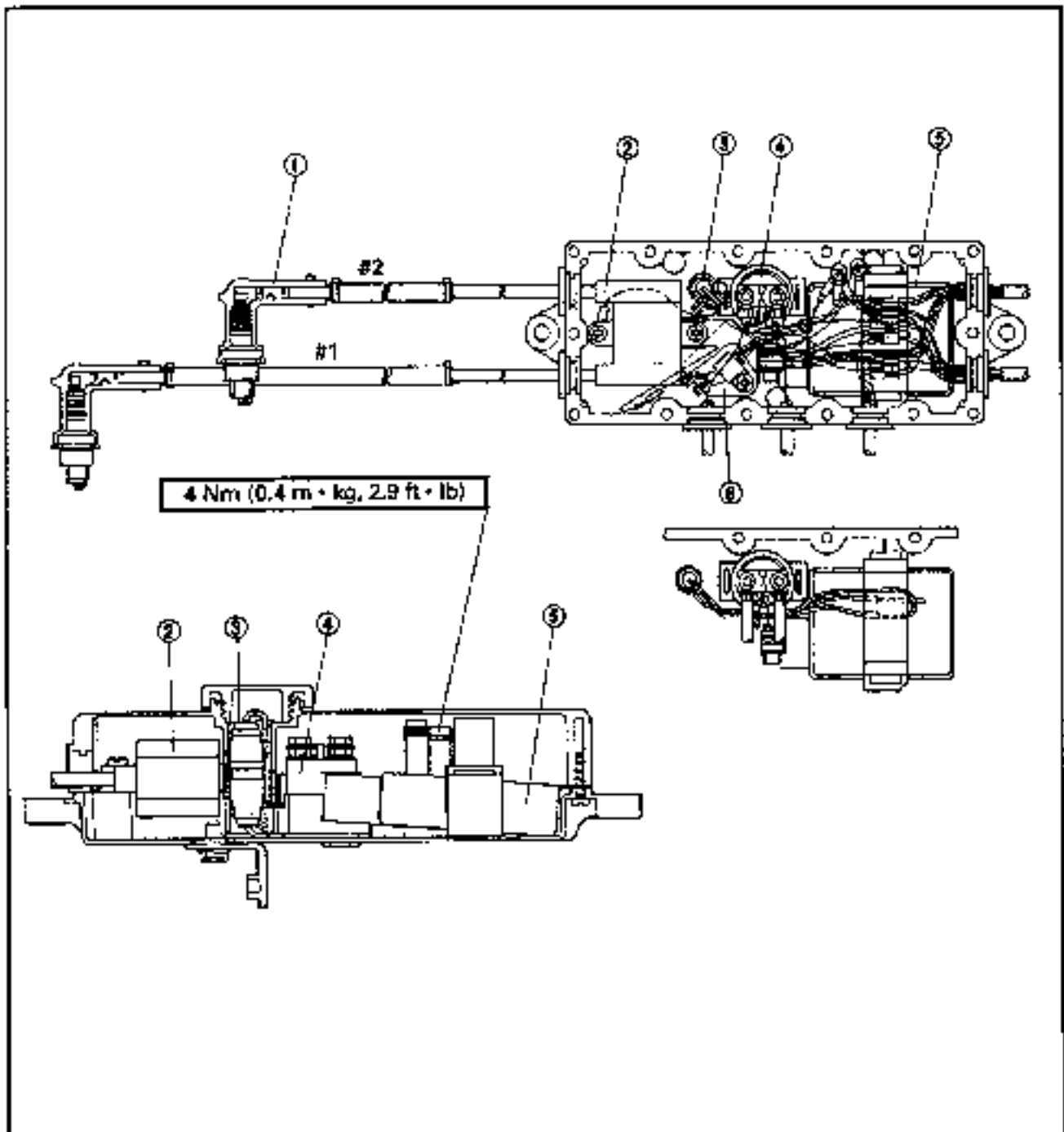

- ① Spark plug cap
- ② Ignition coil
- ③ Fuse
- ④ Starter relay
- ⑤ CDI unit
- ⑥ Rectifier regulator

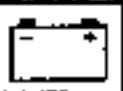

## GP1200

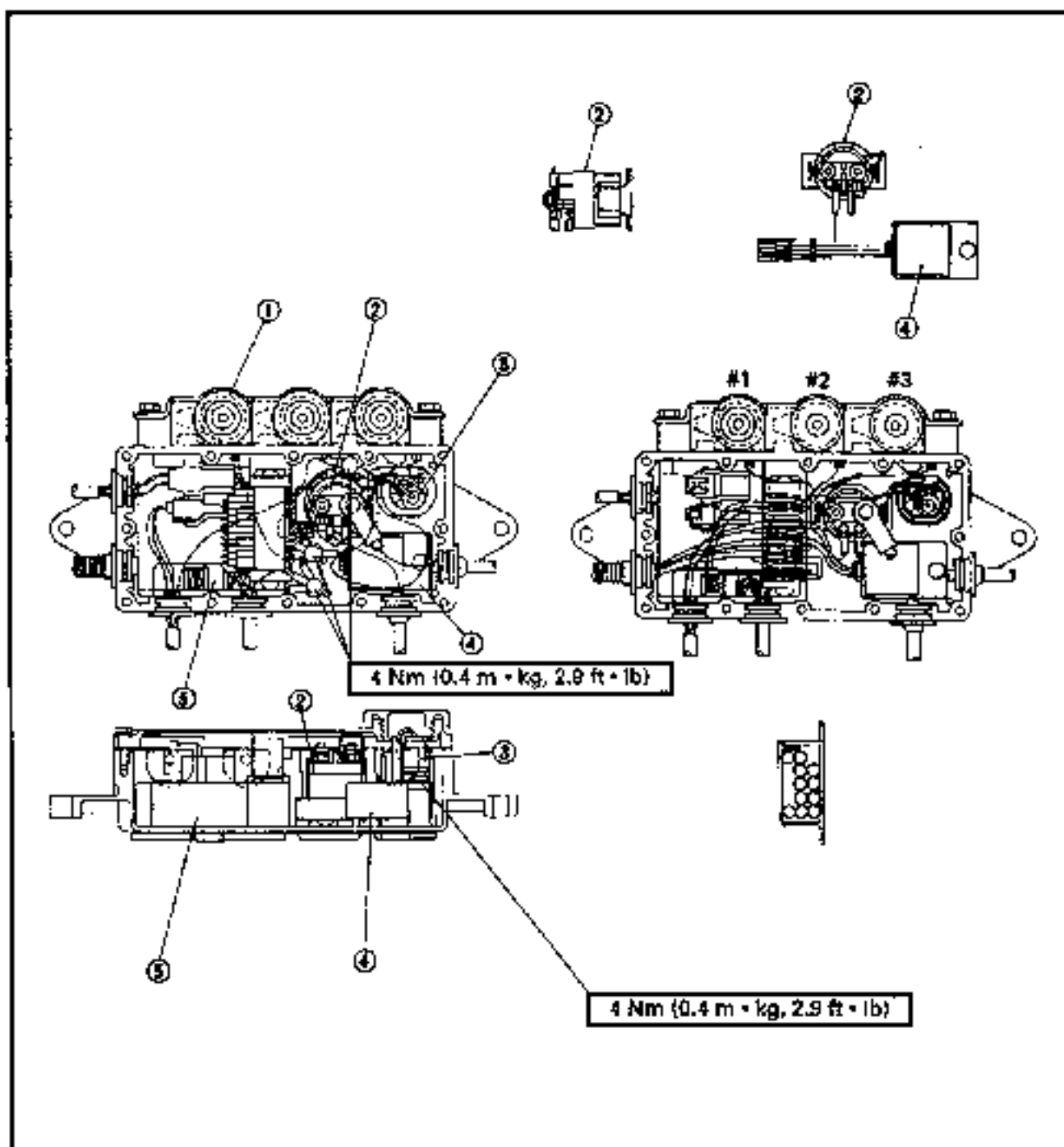

- ① Ignition coil
- ② Starter relay
- ③ Fuse
- ④ Rectifier regulator
- ⑤ CDI unit



## ELECTRICAL ANALYSIS INSPECTION

### General notes

All measuring instruments should be handled with special care, or correct measurement is impossible.

On an instrument powered by dry batteries, the batteries' voltage should be checked periodically and the batteries replaced, if necessary.

### NOTE:

"○—○" indicates the terminals between which there is electrical continuity; i.e., a closed circuit in the given switch position.

### Low resistance measurement

When measuring resistance of 10 Ω or less using the digital tester, the correct measurement cannot be obtained because of the tester's internal resistance.

To obtain the correct value, subtract this internal resistance from the displayed measurement.



**Correct value =**  
**Displayed measurement –**  
**Internal resistance**

### NOTE:

The internal resistance of the tester can be obtained by connecting both of its terminals.





## IGNITION SYSTEM

## WIRING DIAGRAM

GP760

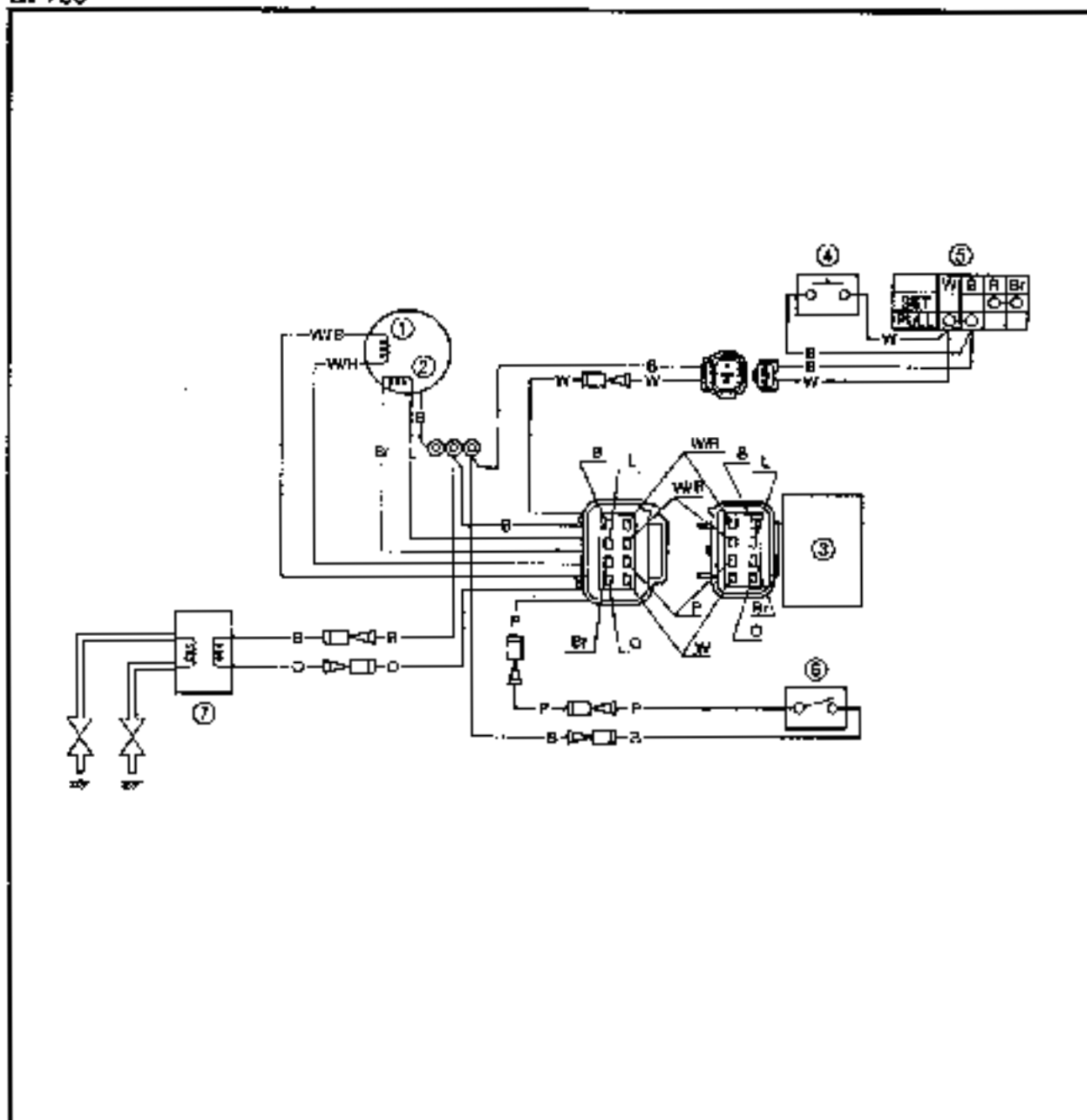

- ① Pulser coil
- ② Charge coil
- ③ CDI unit
- ④ Stop switch
- ⑤ Engine stop switch
- ⑥ Thermo switch
- ⑦ Ignition coil

- B : Black
- Br : Brown
- L : Blue
- O : Orange
- P : Pink
- W : White
- W/B : White/Black
- W/R : White/Red

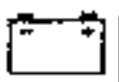

GP1200

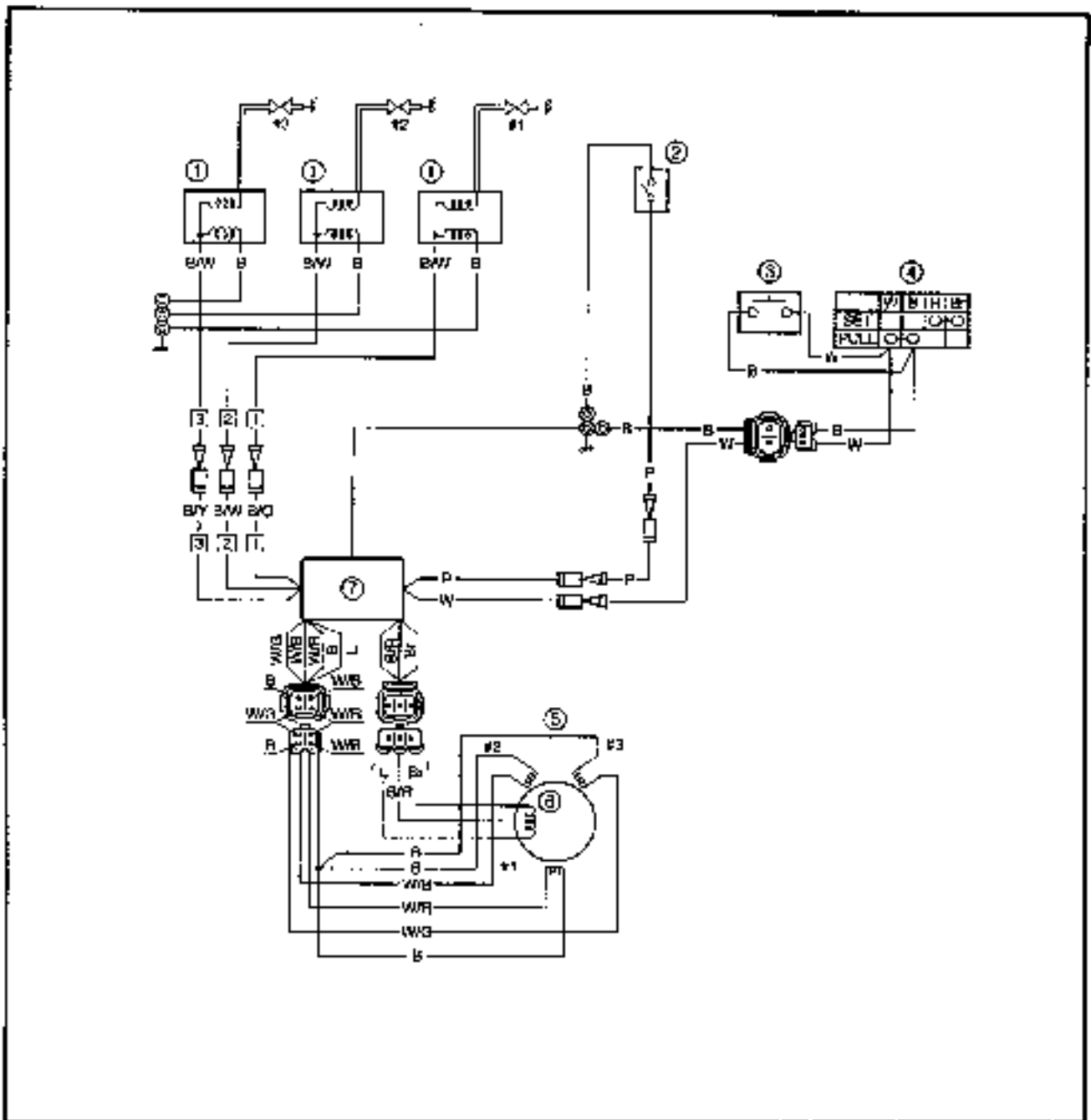

- ① Ignition coil
- ② Thermo switch
- ③ Stop switch
- ④ Engine stop switch
- ⑤ Pulser coil
- ⑥ Charge coil
- ⑦ CDI unit

- B : Black
- B/O : Black/Orange
- B/R : Black/Red
- B/W : Black/White
- B/Y : Black/Yellow
- Br : Brown
- L : Blue
- P : Pink
- W : White
- W/B : White/Black
- W/G : White/Green
- W/R : White/Red

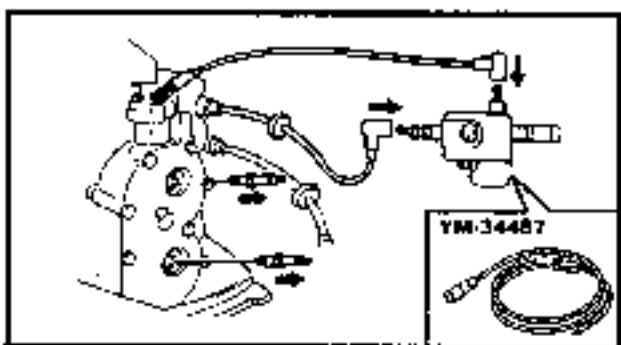
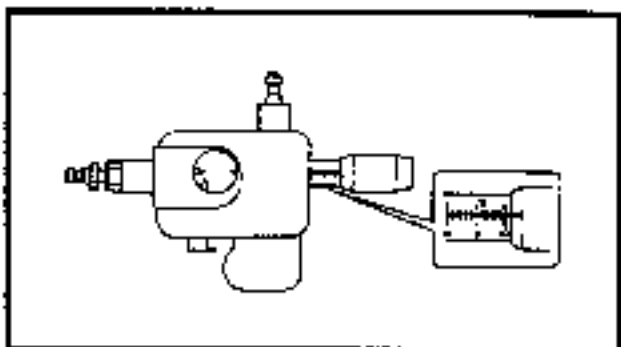
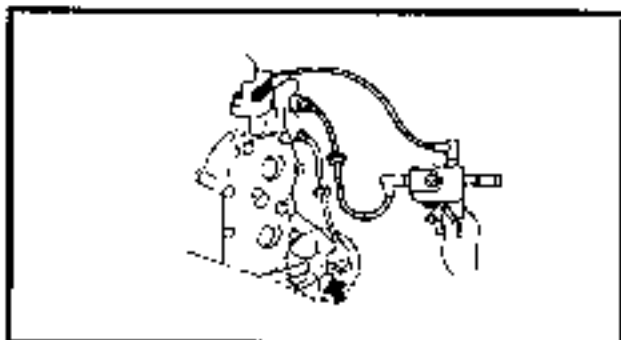
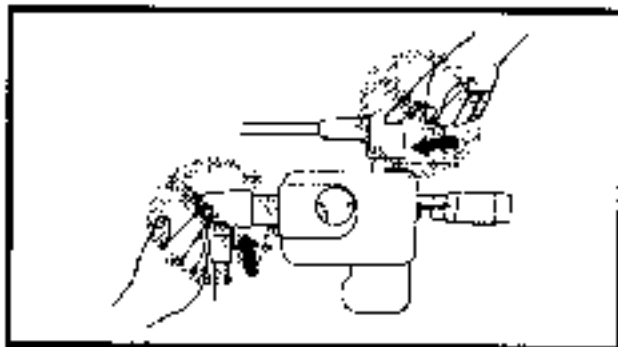
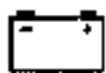

## IGNITION SPARK GAP

**⚠ WARNING**

- While making a spark check be careful not to touch any of the "Ignition spark gap tester" lead wires.
- When doing the spark test, take special care not to allow leakage from the removed plug cap.
- This check is likely to produce sparks, so be sure that no flammable gas or fluid is in the vicinity.

## 1. Check:

- Ignition spark gap  
Out of specification → Replace.



**Spark gap:**  
9 mm (0.35 in)

**Checking steps:**

- Adjust the spark gap to specification by turning the adjusting knob.



**Spark gap tester:**  
YM-34487/90890-06754

- Connect the spark plug cap to the spark gap tester.
- Remove the spark plugs from the engine.
- Crank the engine and check the sparks from the ignition system through the discharge window.

**SPARK PLUG**

Refer to "ELECTRICAL" in chapter 3.

**SPARK PLUG CAP**

## 1. Inspect:

- Spark plug cap  
Loosen → Tighten.  
Crack/Damage → Replace.

## 2. Measure:

- Spark plug cap resistance  
Out of specification → Replace.

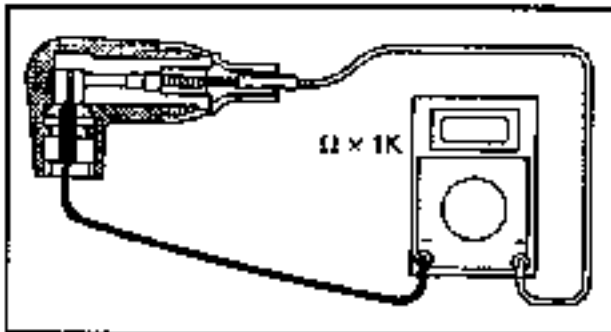

**Spark plug cap resistance:**  
4.0 - 6.0 kΩ

**Replacement steps:**

- Remove the spark plug cap by turning the cap counterclockwise.
- Install the spark plug cap by turning the cap clockwise until it stops.

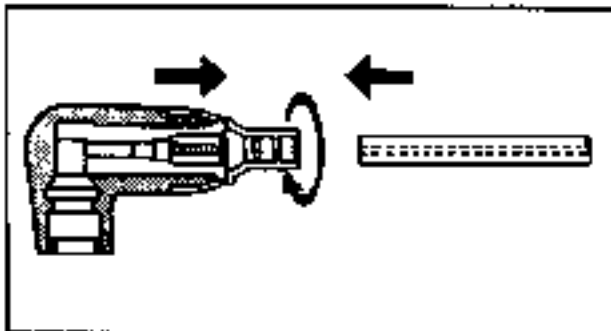
**IGNITION COIL**

## 1. Inspect:

- High tension cord  
Cracks/Damage → Replace.

## 2. Measure:

- Primary coil resistance  
Out of specification → Replace.

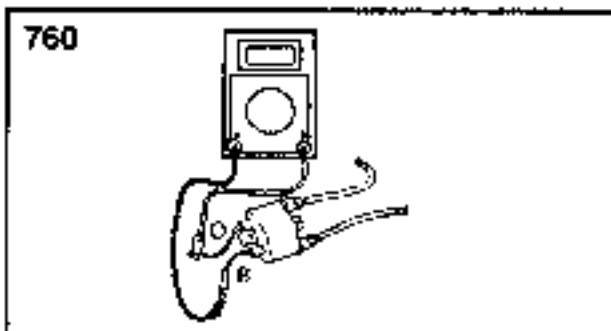

**Primary coil resistance:**  
GP760  
Orange (O) - Black (B)  
0.078 - 0.106 Ω at 20°C (68°F)  
GP1200  
Black/White (B/W) - Black (B)  
0.048 - 0.072 Ω at 20°C (68°F)

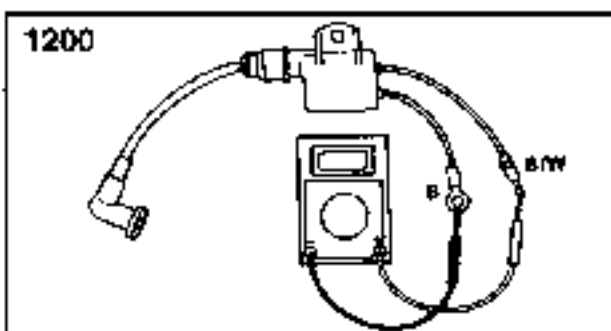
**NOTE:**

When measuring the resistance of 10 Ω or less using the digital tester, the correct measurement cannot be obtained. Refer to "Lower resistance measurement".

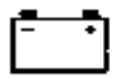

760

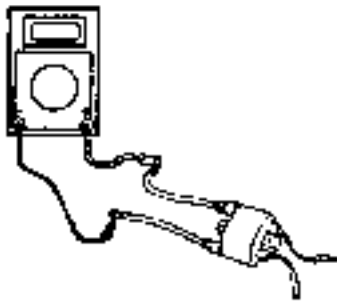

1200

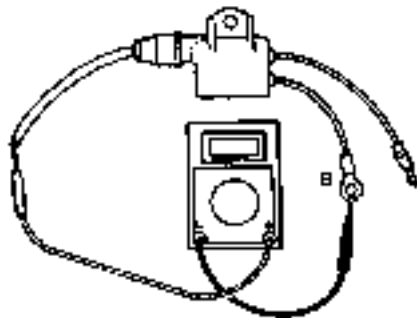

3. Measure:

- Secondary coil resistance  
Out of specification → Replace.

**Secondary coil resistance:****GP760**

High tension cords

14.3 - 30.5 kΩ at 20°C (68°F)

**GP1200**

High tension cord - Black (B)

2.7 - 4.1 kΩ at 20°C (68°F)

**NOTE:**

Remove the spark plug cap from the high tension cord.

**ENGINE STOP SWITCH**

1. Check:

- Continuity  
Out of specification → Replace.

**Engine stop continuity:****(Black coupler)**

Lock plate	Position	Leads	
		White	Black
Installed	Free		
	Push	○—○	○—○
Removed	Free	○—○	○—○
	Push	○—○	○—○

760

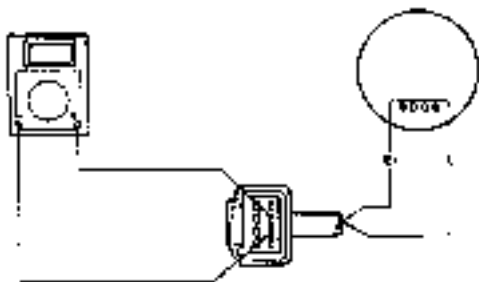

1200

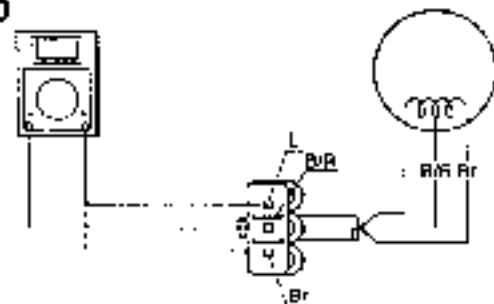
**CHARGE COIL**

1. Measure:

- Charge coil resistance  
Out of specification → Replace.

**Charge coil resistance:****GP760**

Brown (Br) - Blue (L)

316.8 - 387.2 Ω at 20°C (68°F)

**GP1200**

Black/Red (B/R) - Brown (Br)

172.0 - 258.0 Ω at 20°C (68°F)

Black/Red (B/R) - Blue (L)

656.0 - 984.0 Ω at 20°C (68°F)

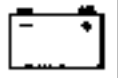

760

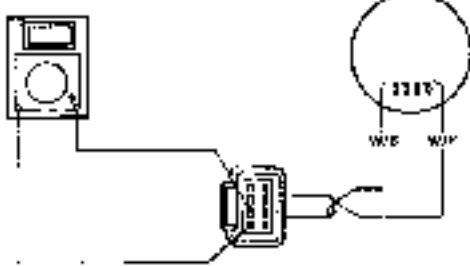

1200

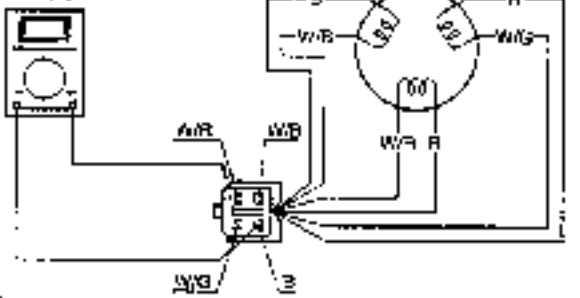

## PULSER COIL

## 1. Measure:

- Pulser coil resistance

Out of specification → Replace.



## Pulser coil resistance:

GP760

White/Red (W/R) –

White/Black (W/B)

445.5 - 544.5  $\Omega$  at 20°C (68°F)

GP1200

White/Red (W/R) – Black (B)

White/Black (W/B) – Black (B)

White/Green (W/G) – Black (B)

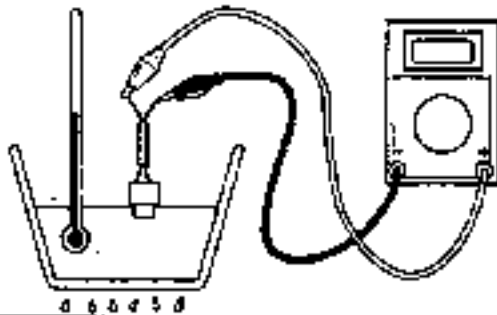
248.0 - 372.0  $\Omega$  at 20°C (68°F)

## THERMO SWITCH

## 1. Measure:

- Thermo switch continuity

Out of specification → Replace.

Thermo switch continuity  
temperature:

Pink (P) – Black (B)

Ⓐ 90 - 96°C (194 - 205°F)

Ⓑ 76 - 90°C (169 - 194°F)

Ⓐ Discontinuity

Ⓑ Continuity

Ⓐ Temperature

Ⓑ Time

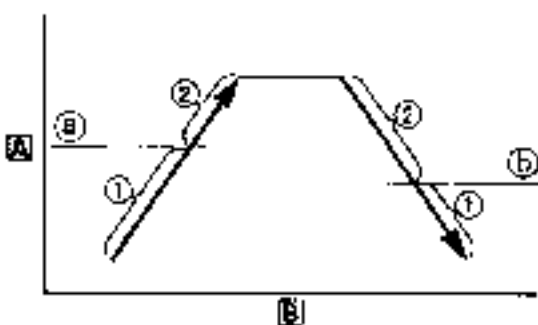

## Measurement steps:

- Suspend thermostat in a vessel.
- Place known reliable thermometer in water.
- Heat water slowly.
- Observe thermometer, while stirring water continually.

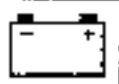

### CDI UNIT

#### 1. Measure:

- CDI unit resistance

Out of specification → Replace.



Pocket tester:

YU-03112/90890-03112

#### NOTE:

- The resistance values will vary from meter to meter, especially with electronic digital meters. For some testers, the polarity of the leads is reversed.
- The needle swings once to the "\*" mark and then returns to the home position.
- The "∞" mark stands for discontinuity.

B : Black  
 B/O : Black/Orange  
 B/R : Black/Red  
 B/W : Black/White  
 B/Y : Black/Yellow  
 Br : Brown  
 L : Blue  
 O : Orange  
 P : Pink  
 W : White  
 W/B : White/Black  
 W/G : White/Green  
 W/R : White/Red

#### GP780

Unit: kΩ

⊕	⊖	B	Br	L	O	P	W	W/B	W/R
B			70 ~ 400	6 ~ 26	2 ~ 8.5	∞	10 ~ 45	0 ~ 0.6	4.4 ~ 19
Br		2.4 ~ 11		16 ~ 70	7.5 ~ 35	∞	26 ~ 150	2.4 ~ 11	9 ~ 40
L		2.4 ~ 11	80 ~ 500		7.5 ~ 35	∞	26 ~ 150	2.4 ~ 11	9 ~ 40
O		∞	∞	∞		∞	∞	∞	∞
P		17 ~ 80	70 ~ 1,000	15 ~ 70	40 ~ 300		7.5 ~ 35	17 ~ 70	22 ~ 100
W		3.8 ~ 18	80 ~ 400	3.4 ~ 14	11 ~ 45	∞		3.8 ~ 16	9.5 ~ 4.0
W/B		0 ~ 0.6	70 ~ 400	6 ~ 26	2 ~ 9	∞	10 ~ 45		4.4 ~ 18
W/R		4 ~ 17	70 ~ 400	13 ~ 60	8 ~ 35	∞	16 ~ 70	4 ~ 17	

#### GP1200

Unit: kΩ

⊕	⊖	B	B/O	B/R	B/W	B/Y	Br	L	P	W	W/B	W/G	W/R
B		3.5 ~ 5.0	3.3 ~ 4.9	3.4 ~ 5.1	3.5 ~ 5.0	∞	∞	3.2 ~ 4.8	7.8 ~ 11.8	3.2 ~ 13.8	400 ~ 800	400 ~ 800	400 ~ 500
B/O		∞		∞	∞	∞	∞	∞	∞	∞	∞	∞	∞
B/R		∞	∞		∞	∞	∞	∞	∞	∞	∞	∞	∞
B/W		∞	∞	∞		∞	∞	∞	∞	∞	∞	∞	∞
B/Y		∞	∞	∞	∞		∞	∞	∞	∞	∞	∞	∞
Br		76 ~ 114	120 ~ 180	112 ~ 166	120 ~ 180	120 ~ 180		112 ~ 168	120 ~ 180	120 ~ 180	∞	∞	∞
L		22 ~ 34	40 ~ 71	58 ~ 84	60 ~ 74	60 ~ 74	∞		38 ~ 58	40 ~ 60	∞	∞	∞
P				∞	∞	∞	∞	∞	∞	∞	∞	∞	∞
W		∞	∞	∞	∞	∞	∞	∞	∞	∞	∞	∞	∞
W/B		112 ~ 168	168 ~ 252	160 ~ 240	168 ~ 252	168 ~ 252	∞	160 ~ 240	168 ~ 252	168 ~ 252	∞	∞	∞
W/G		200 ~ 300	312 ~ 468	280 ~ 420	312 ~ 468	312 ~ 468	∞	280 ~ 420	312 ~ 468	312 ~ 468	∞	∞	∞
W/R		112 ~ 168	168 ~ 252	100 ~ 240	168 ~ 252	168 ~ 252	∞	168 ~ 252	168 ~ 252	168 ~ 252	∞	∞	∞



# STARTING SYSTEM WIRING DIAGRAM

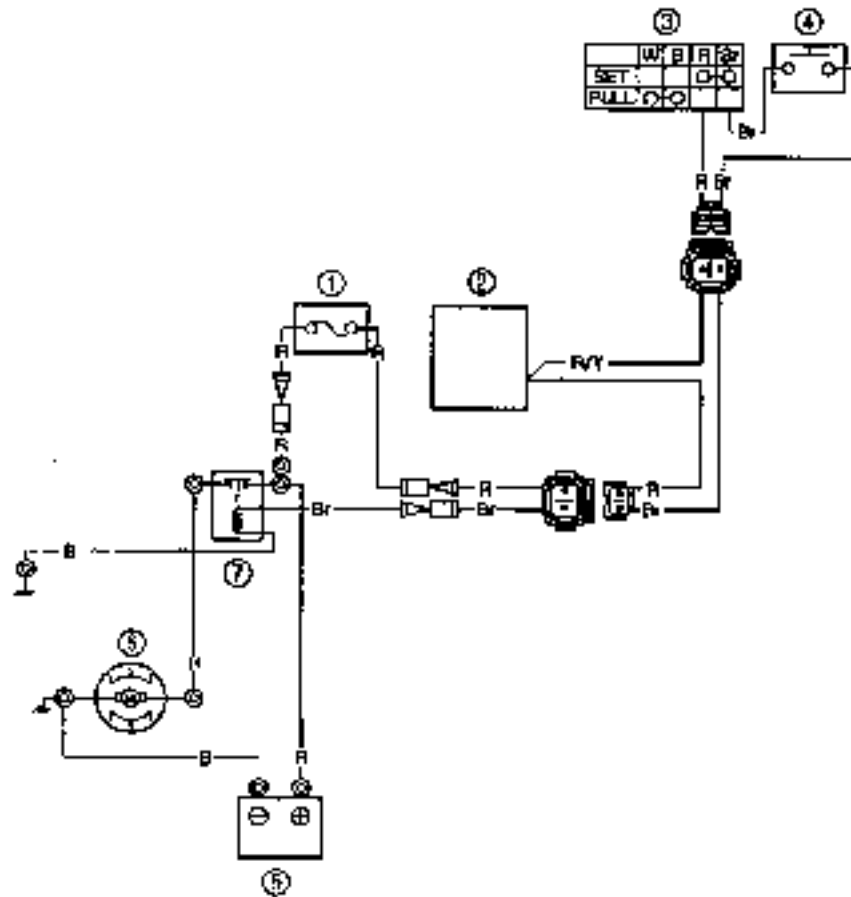

- ① Fuse
- ② Multifunction meter
- ③ Engine stop switch
- ④ Starter switch
- ⑤ Battery
- ⑥ Starter motor
- ⑦ Starter relay

B : Black  
 Br : Brown  
 R : Red  
 R/Y: Red/Yellow



**BATTERY**

Refer to "ELECTRICAL" in chapter 3.

**STARTER MOTOR**

Refer to "STARTER MOTOR" in chapter 5.

**WIRING CONNECTION**

- 1. Check:
  - Wiring connection
  - Poor connection → Correct.

**FUSE**

- 1. Check:
  - Fuse
  - Blown → Replace.

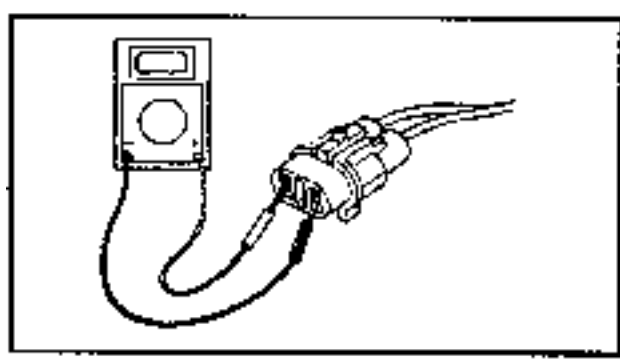

	<b>Fuse rating:</b> 12 V/10 A
---	----------------------------------

**STARTER SWITCH**

- 1. Check:
  - Continuity
  - Out of specification → Replace.

	<b>Starter continuity:</b> (Red coupler)		
Lock plate	Position	Leads	
		Red	Brown
Installed	Free		
	Push	○-----○	
Removed	Free		
	Push		

**STARTER RELAY**

- 1. Inspect:
  - Brown lead terminal
  - Black lead terminal
  - Loose → Tighten.

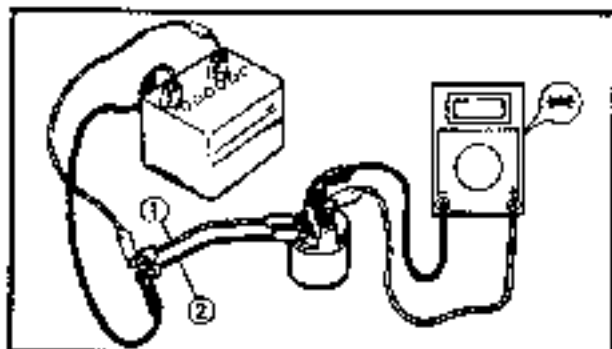

2. Check:

- Relay operation  
Not working → Replace.

**Checking steps:**

- Connect the tester between the terminals of the starter relay as shown.
- Connect a 12 V battery.

**Brown lead (1) → Positive terminal**

**Black lead (2) → Negative terminal**

- Check that there is continuity between the starter relay terminals.

CHARGING SYSTEM  
WIRING DIAGRAM

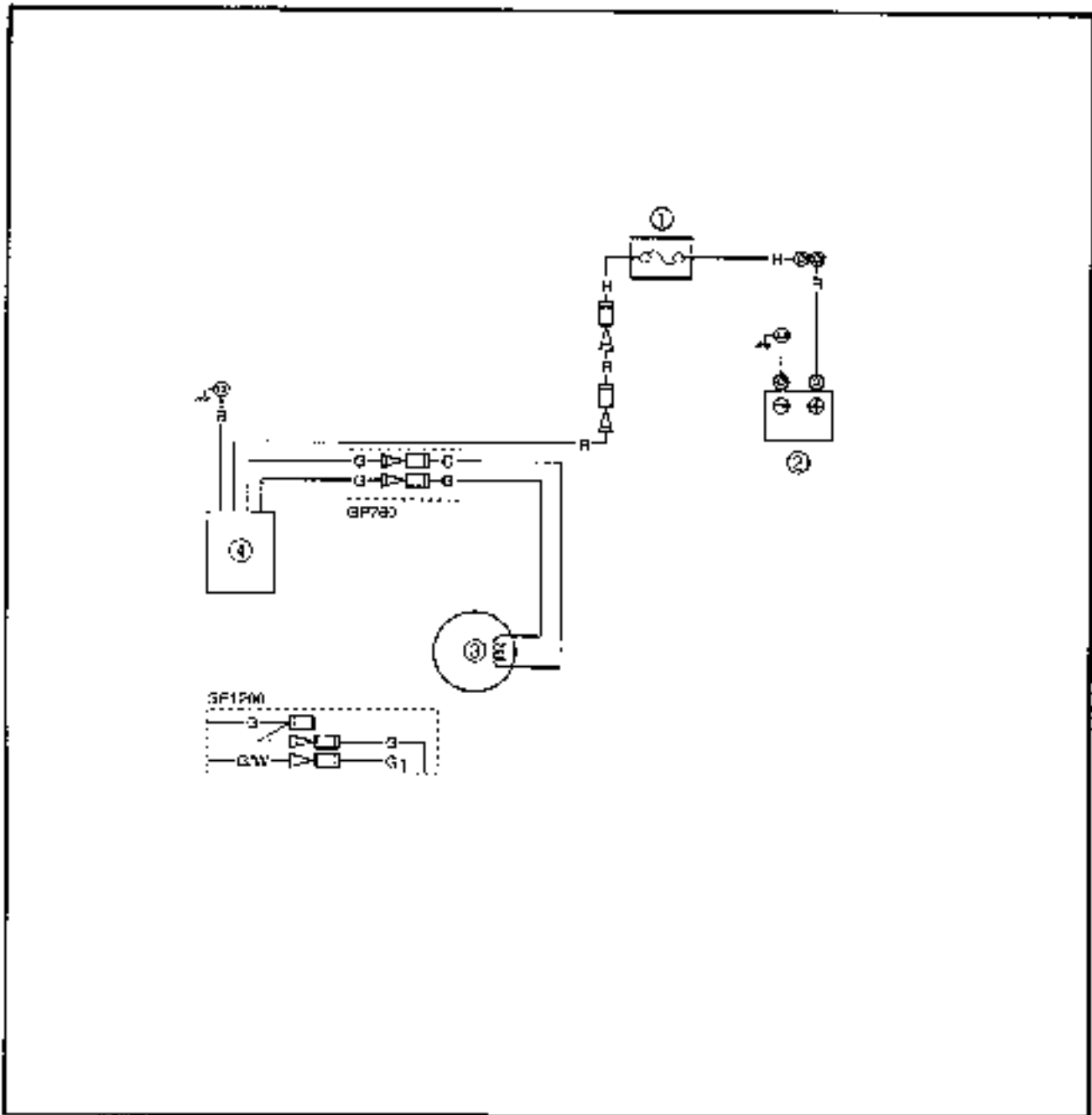

- ① Fuse
- ② Battery
- ③ Lighting coil
- ④ Rectifier/regulator

- B : Black
- G : Green
- G/W : Green/White
- R : Red

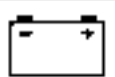
**FUSE**

Refer to "STARTING SYSTEM".

**BATTERY**

Refer to "ELECTRICAL" in chapter 3.

**LIGHTING COIL**

1. Measure:

- Lighting coil resistance  
Out of specification → Replace.

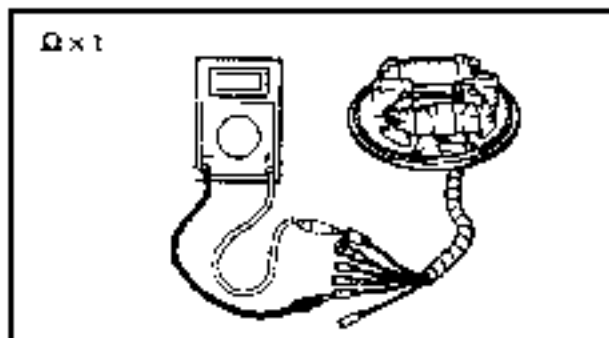
**Lighting coil resistance:****GP760****Green (G) – Green (G)**

1.14 – 1.40 Ω at 20°C (68°F)

**GP1200****Green (G) – Green (G)**

0.56 – 0.84 Ω at 20°C (68°F)

**NOTE:**

When measuring the resistance of 10 Ω or less using the digital tester, the correct measurement cannot be obtained. Refer to "Lower resistance measurement".

**RECTIFIER REGULATOR**

1. Check:

- Continuity  
Out of specification - → Replace.

**Pocket tester:****YU-03112/90890-03112**

○: Continuity

∞: Discontinuity

760

Unit: kΩ

⊕ \ ⊖	R	B	G	G
R		∞	∞	∞
B	2 ~ 20		1 ~ 10	1 ~ 10
G	1 ~ 10	2 ~ 15		3 ~ 30
G	1 ~ 10	2 ~ 15	3 ~ 30	

1200

Unit: kΩ

⊕ \ ⊖	R	B	G	G/W
R		∞	∞	∞
B	○		○	○
G	○	∞		∞
G/W	○	○	○	



## INDICATION SYSTEM WIRING DIAGRAM

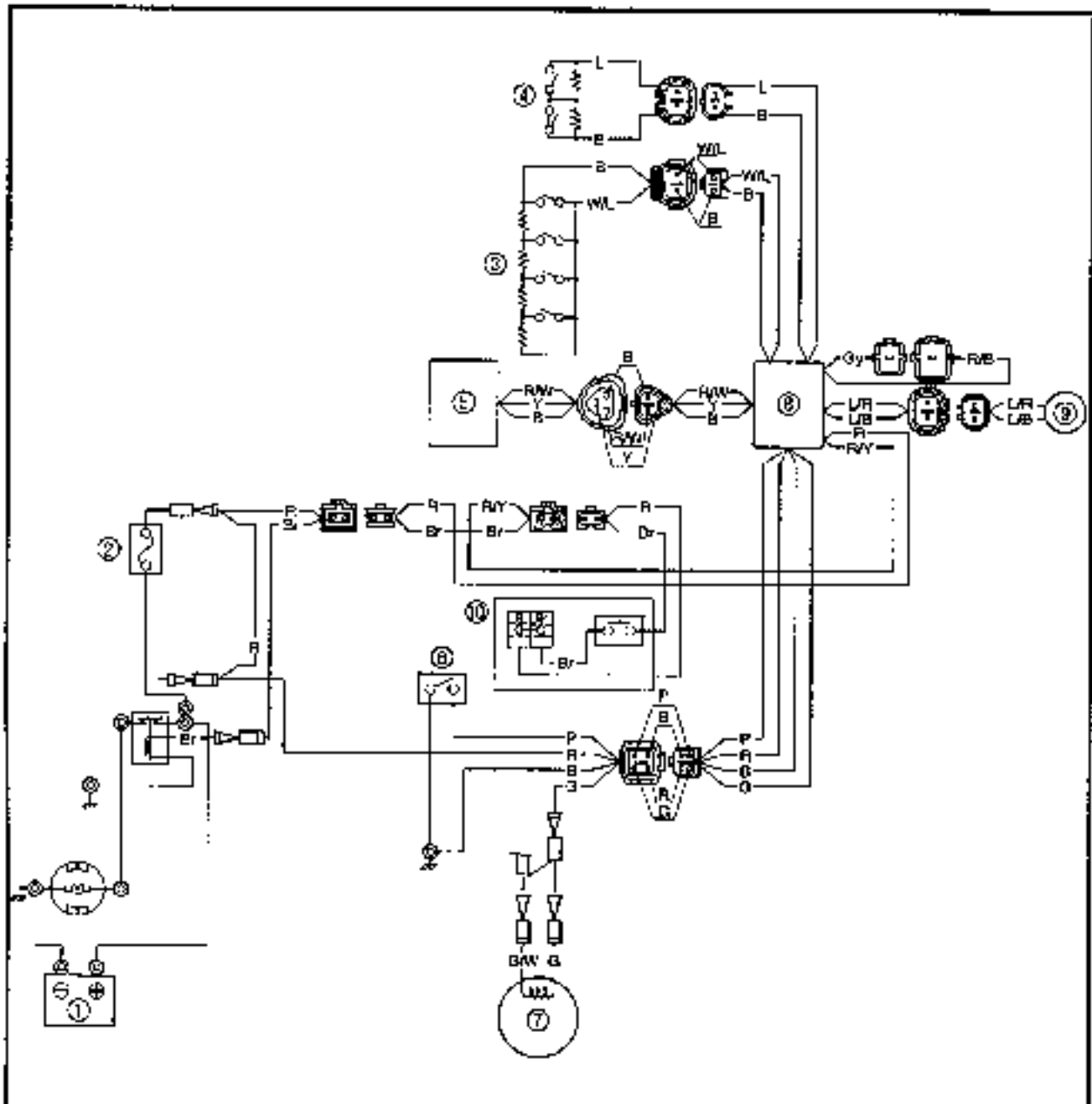

- ① Battery
- ② Fuse
- ③ Fuel level sensor
- ④ Oil level sensor
- ⑤ Speed sensor
- ⑥ Thermo switch
- ⑦ Lighting coil
- ⑧ Multi-function meter
- ⑨ Buzzer
- ⑩ Handlebar switch (starting switch)

- B : Black
- G : Green
- G/W : Green/White
- L : Blue
- L/B : Blue/Black
- L/R : Blue/Red
- P : Pink
- R : Red
- R/W : Red/White
- W/L : White/Blue
- Y : Yellow

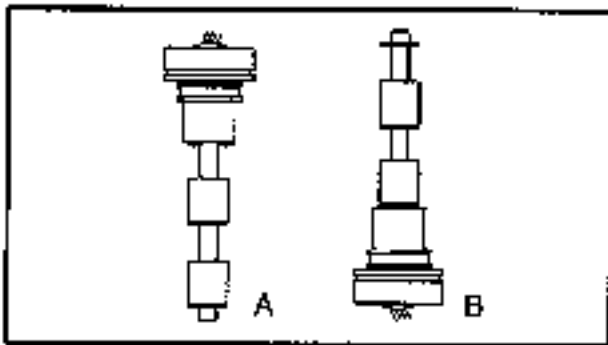
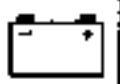
**OIL LEVEL SENSOR**

1. Measure:

- Oil level sensor resistance  
Out of specification → Replace.

Blue - Black	
 Sensor position	Resistance (Ω)
A	292 ~ 308
B	0 ~ 3

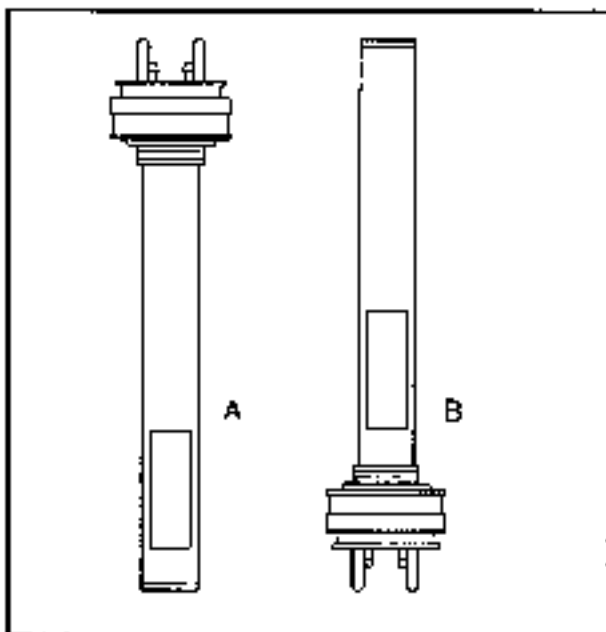
**FUEL LEVEL SENSOR**

1 Measure:

- Fuel level sensor resistance  
Out of specification → Replace.

White/Blue - Black	
 Sensor position	Resistance (Ω)
A	757 ~ 803
B	0 ~ 8

**FUSE**

Refer to "STARTING SYSTEM".

**BATTERY**

Refer to "ELECTRICAL" in chapter 3.

**LIGHTING COIL**

Refer to "CHARGING SYSTEM".

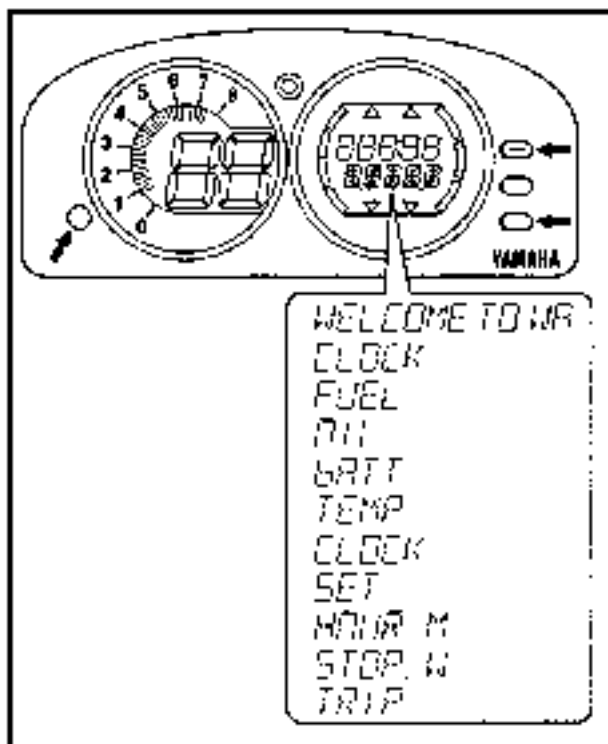

**MULTI-FUNCTION METER**  
 Instrument indicating function

1. Check:
  - Indicating function  
 An indicating error is found → Replace the multi-function meter.

Sequential output (1 minute/cycle)	
1	Display begins operation
2	"WELCOME TO WAVE RINNERS"
3	All LCD readouts turn on
4	"CLOCK" is displayed
5	"FUEL" is displayed
6	"OIL" is displayed
7	"BATT" is displayed
8	"TEMP" is displayed
9	"CLOCK" is displayed
10	"SET" is displayed
11	"HOUR, M" is displayed
12	"STOP, W" is displayed
13	"TRIP" is displayed

**Checking steps:**

- Connect the battery terminals.

**NOTE:**

If the multi-function meter has been removed, supply battery power to the four-pin coupler (+: Red, -: Black).

- Remove the blue, one-pin couplers ①.  
 → The warning lamp blinks ②.
- Press the "MODE" ③, "A/SET" ④, and "C" ⑥ buttons (all at once) for more than three seconds.  
 → The self-indicating function is activated.
- Press either button ④, ⑤, or ⑥.  
 → Self-indication stops and the warning lamp ② blinks.
- Connect the blue, one-pin couplers.  
 → The warning lamp ② turns off and all indications stop.

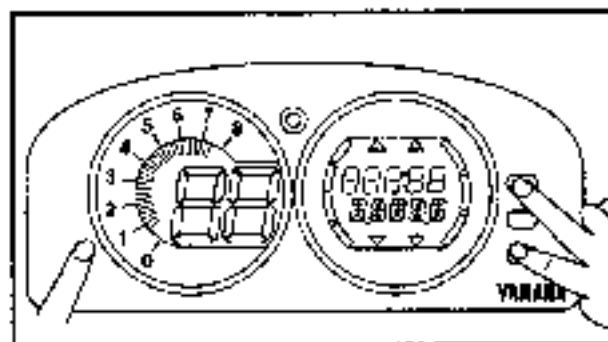
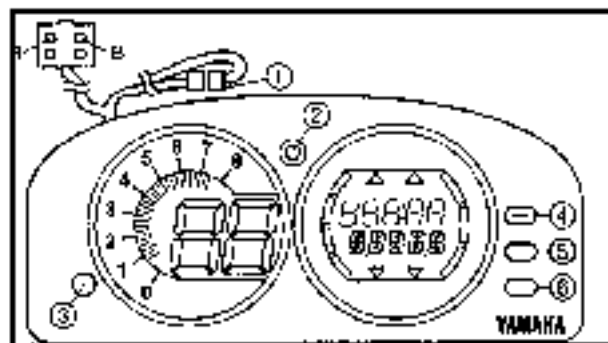

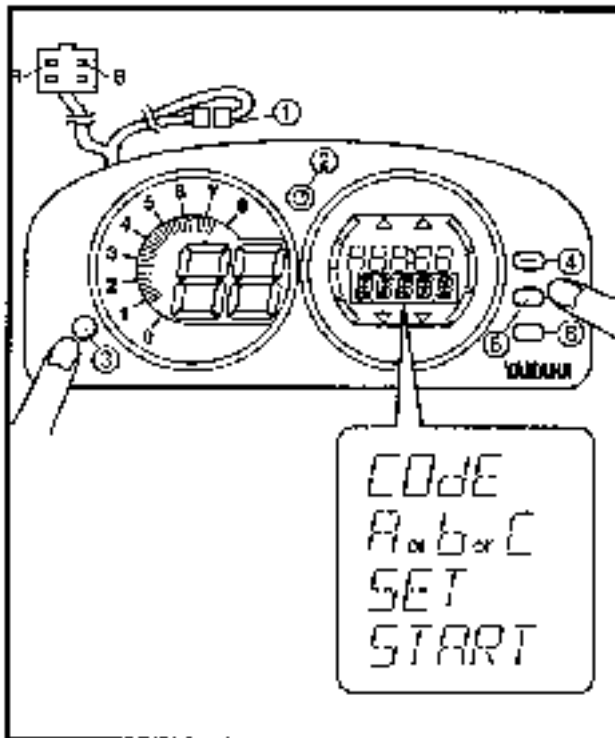
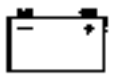

### Security function

#### 1. Check:

- Sequential output  
An error is found → Replace the multi-function meter.

### Checking steps:

- Connect the battery terminals.

### NOTE:

If the multi-function meter has been removed, supply battery power to the four-pin coupler (+: Red, -: Black).

- Remove the blue, one-pin couplers ①.  
→ The warning lamp blinks ②.
- Press the "MODE" ③ button for more than three seconds.  
→ The warning lamp ② blinks.  
→ "CODE" is displayed and blinks.
- Enter the four-digit code with either button ④, ⑤, or ⑥.
  - 1) The buzzer sounds when the button is pushed.
  - 2) When the warning lamp ② is lit, "A", "B" or "C" is displayed for code entry, then "SET" is displayed and blinks.
  - 3) The buzzer sounds three times and then "START" is displayed.
  - 4) The display then clears and the warning lamp ② blinks.
- Connect the blue, one-pin couplers ①.  
→ The warning lamp ② turns off.



## CHAPTER 8 HULL AND HOOD

<b>HANDLE REMOVAL</b> .....	8 - 1
EXPLODED DIAGRAM .....	8 - 1
REMOVAL AND INSTALLATION CHART .....	8 - 1
SERVICE POINTS .....	8 - 2
Handlebar assembly installation .....	8 - 2
<b>HANDLE</b> .....	8 - 4
EXPLODED DIAGRAM .....	8 - 4
REMOVAL AND INSTALLATION CHART .....	8 - 4
SERVICE POINTS .....	8 - 5
Handle inspection .....	8 - 5
Handle switch inspection .....	8 - 5
Handle switch installation .....	8 - 5
<b>TRIM GRIP AND CONTROL CABLE</b> .....	8 - 6
EXPLODED DIAGRAM .....	8 - 6
REMOVAL AND INSTALLATION CHART .....	8 - 6
SERVICE POINTS .....	8 - 7
Trim control cable inspection .....	8 - 7
Grip guide inspection .....	8 - 7
<b>ENGINE HOOD COVER</b> .....	8 - 8
EXPLODED DIAGRAM .....	8 - 8
REMOVAL AND INSTALLATION CHART .....	8 - 8
<b>HANDLE COLUMN</b> .....	8 - 9
EXPLODED DIAGRAM .....	8 - 9
REMOVAL AND INSTALLATION CHART .....	8 - 9
SERVICE POINTS .....	8 - 10
Bushing inspection .....	8 - 10
Handle column inspection .....	8 - 10
Bushing joint installation .....	8 - 10
<b>ADJUSTABLE MIRROR AND ENGINE HOOD REMOVAL</b> .....	8 - 11
EXPLODED DIAGRAM .....	8 - 11
REMOVAL AND INSTALLATION CHART .....	8 - 11
<b>ENGINE HOOD</b> .....	8 - 12
EXPLODED DIAGRAM .....	8 - 12
REMOVAL AND INSTALLATION CHART .....	8 - 12

<b>STEERING CABLE</b> .....	8 - 13
EXPLODED DIAGRAM .....	8 - 13
REMOVAL AND INSTALLATION CHART .....	8 - 13
SERVICE POINTS .....	8 - 14
Cable inspection .....	8 - 14
Jet pump side cable joint installation .....	8 - 14
Cable stopper installation .....	8 - 14
Steering cable adjustment .....	8 - 14
 <b>THROTTLE CABLE AND CHOKE CABLE</b> .....	8 - 15
EXPLODED DIAGRAM .....	8 - 15
REMOVAL AND INSTALLATION CHART .....	8 - 15
SERVICE POINTS .....	8 - 16
Cable inspection .....	8 - 16
Cable installation .....	8 - 16
Throttle cable adjustment .....	8 - 16
Choke cable adjustment .....	8 - 16
 <b>TRIM CABLE</b> .....	8 - 17
EXPLODED DIAGRAM .....	8 - 17
REMOVAL AND INSTALLATION CHART .....	8 - 17
SERVICE POINTS .....	8 - 18
Cable inspection .....	8 - 18
Trim cable adjustment .....	8 - 18
 <b>SEAT, STORAGE BOX AND BATTERY CASE</b> .....	8 - 19
EXPLODED DIAGRAM .....	8 - 19
REMOVAL AND INSTALLATION CHART .....	8 - 19
SERVICE POINTS .....	8 - 20
Seat inspection .....	8 - 20
Storage box inspection .....	8 - 20
Battery case inspection .....	8 - 20
 <b>EXHAUST SYSTEM</b> .....	8 - 21
EXPLODED DIAGRAM .....	8 - 21
REMOVAL AND INSTALLATION CHART .....	8 - 21
SERVICE POINTS .....	8 - 22
Exhaust system inspection .....	8 - 22
 <b>DECK</b> .....	8 - 23
EXPLODED DIAGRAM .....	8 - 23
REMOVAL AND INSTALLATION CHART .....	8 - 23
SERVICE POINTS .....	8 - 24
Ventilation system inspection .....	8 - 24

<b>GUNWALE</b> .....	8 - 25
EXPLODED DIAGRAM .....	8 - 25
REMOVAL AND INSTALLATION CHART .....	8 - 25
 <b>MAT</b> .....	 8 - 26
EXPLODED DIAGRAM .....	8 - 26
REMOVAL AND INSTALLATION CHART .....	8 - 26
SERVICE POINTS .....	8 - 26
Mat inspection .....	8 - 26
 <b>HULL</b> .....	 8 - 27
EXPLODED DIAGRAM .....	8 - 27
REMOVAL AND INSTALLATION CHART .....	8 - 27
HULL REPAIR .....	8 - 28
Light scratching .....	8 - 28
Deep scratching .....	8 - 28
Hull damage (punctured) .....	8 - 29
Insert nut .....	8 - 30
Removing a graphic .....	8 - 32
Applying a graphic .....	8 - 32

**HANDLE REMOVAL  
EXPLODED DIAGRAM**

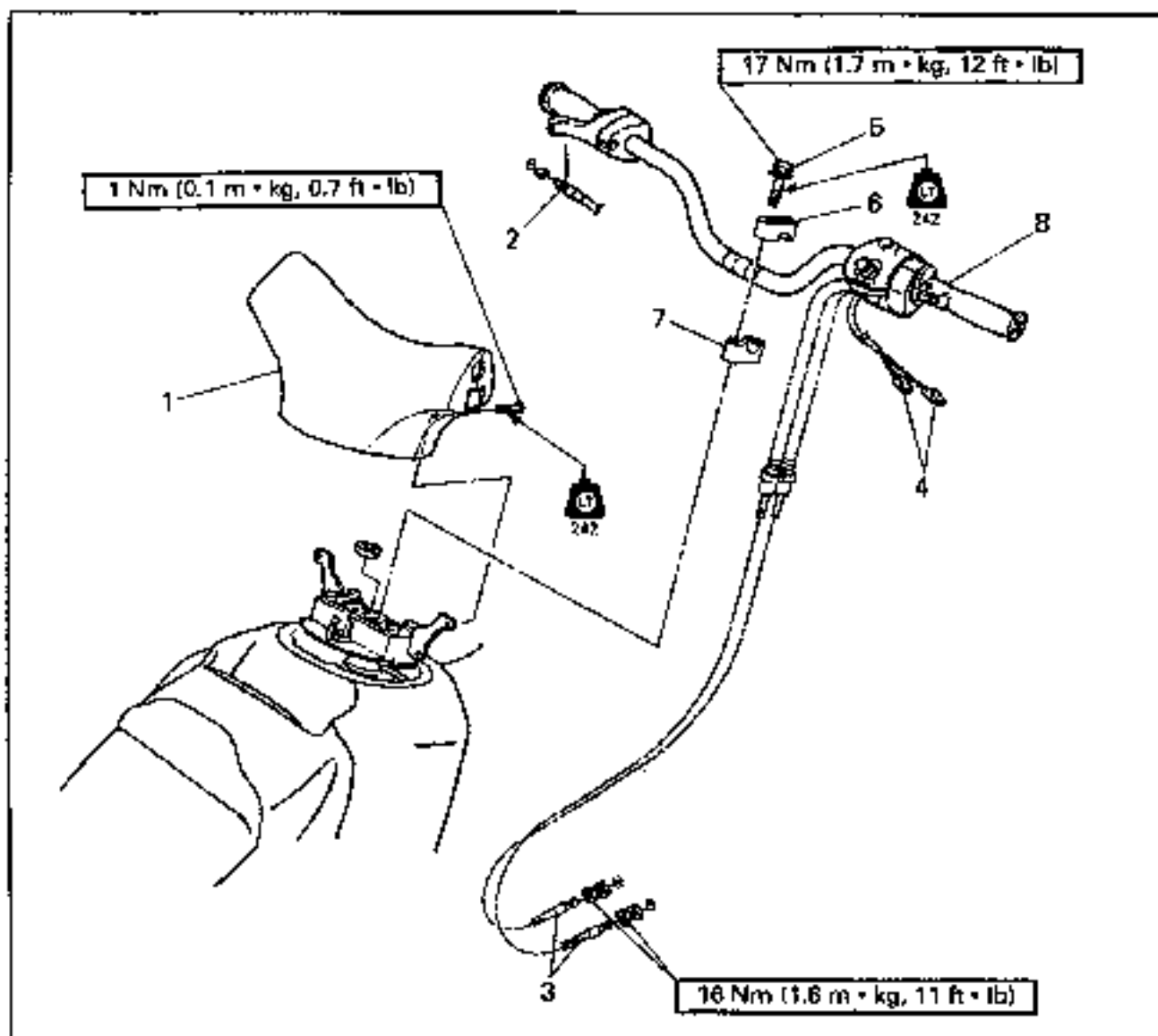

**REMOVAL AND INSTALLATION CHART**

Step	Procedure/Part name	Q'ty	Service points
<b>HANDLE REMOVAL</b>			
1	Steering pad	1	Follow the left "Step" for removal.
2	Throttle cable	1	<b>NOTE:</b> _____ Disconnect the throttle cable from the throttle lever.
3	Trim control cable 1, 2	2	
4	Handle switch lead coupler	2	
5	Bolt (with washer)	4	8 x 55 mm
6	Handlebar holder (upper)	2	
7	Handlebar holder (lower)	2	
8	Handlebar assembly	1	
Reverse the removal steps for installation.			

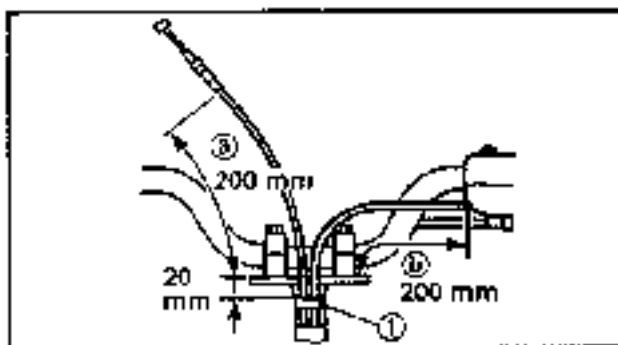
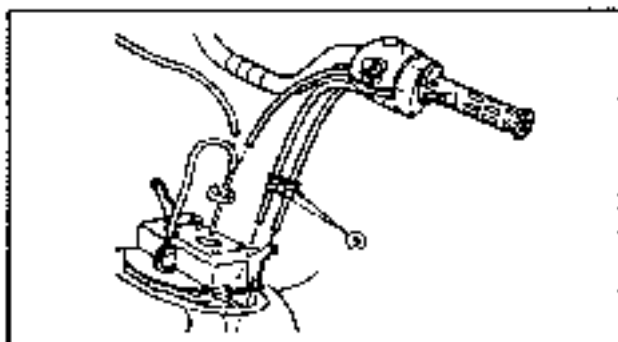

**SERVICE POINTS**

**Handlebar assembly Installation**

1. Install:
  - Nozzle control cable 1, 2

**NOTE:**

After inserting the cables into the engine hood cover, make sure the insertion opening is made water tight with the packing (a).

2. Install:
  - Seal packing (1).

**NOTE:**

- Pass the handle switch lead through the steering shaft.
- Adjust the throttle cable length (a) and handle switch lead length (b) to 200 mm (7.9 in).
- Seal the steering shaft with the seal packing at 20 mm (0.79 in) from the end of the steering column.

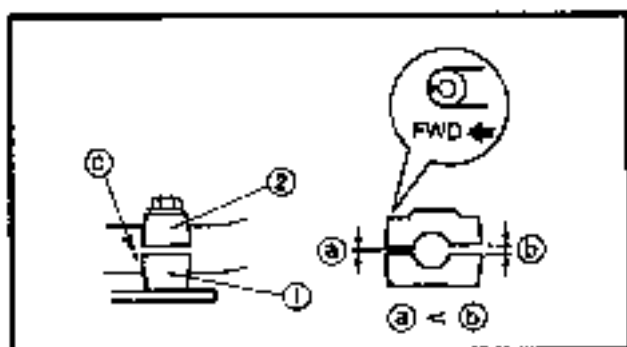

3. Install:
  - Handlebar holder (lower) (1)
  - Handlebar holder (upper) (2)



Clearance (a) should be narrowed than clearance (b).

**NOTE:**

- Align the punch mark (c) on the handlebar with the top surface of the handlebar holder (lower).
- The handlebar holder (upper) should be installed with the punched mark forward.

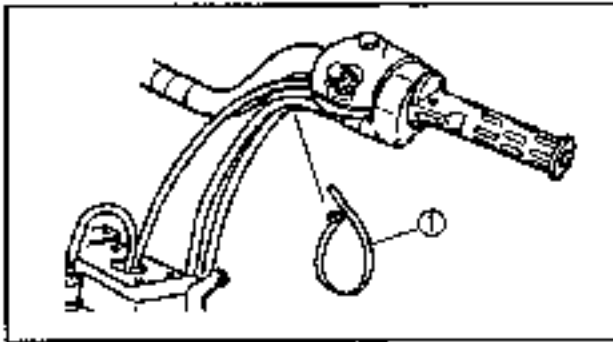

## 4. Install:

- Clamp ①

**NOTE:**

Clamp the handle switch lead and nozzle control cables to the handlebar.

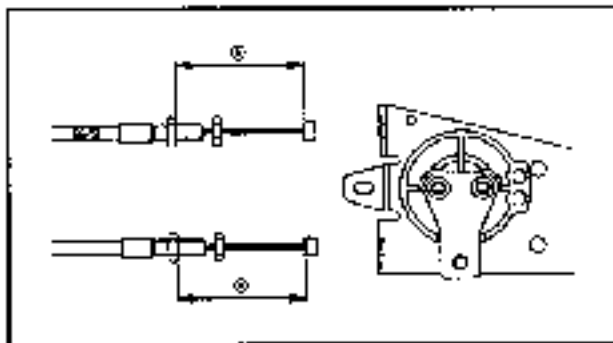

## 5. Adjust:

- Inner cable length ③, ④



**Nozzle control cable length ③, ④:**  
 $77 \pm 0.5 \text{ mm}$  ( $3.03 \pm 0.02 \text{ in}$ )  
 Between adjust nut top and  
 inner cable end.

**NOTE:**

- Before adjusting the nozzle control cables, with the trim grip in the neutral.
- Adjust the inner cable length ③ and ④ to specified to take up the slack.
- Install the cable (white taped) to the "D" marked slot in the base bracket.

## 6. Adjust:

- Throttle cable free play  
 Refer to "CONTROL SYSTEM" in chapter 3.

## 7. Adjust:

- Trim control cable free play  
 Refer to "CONTROL SYSTEM" in chapter 3.

**HANDLE  
EXPLODED DIAGRAM**

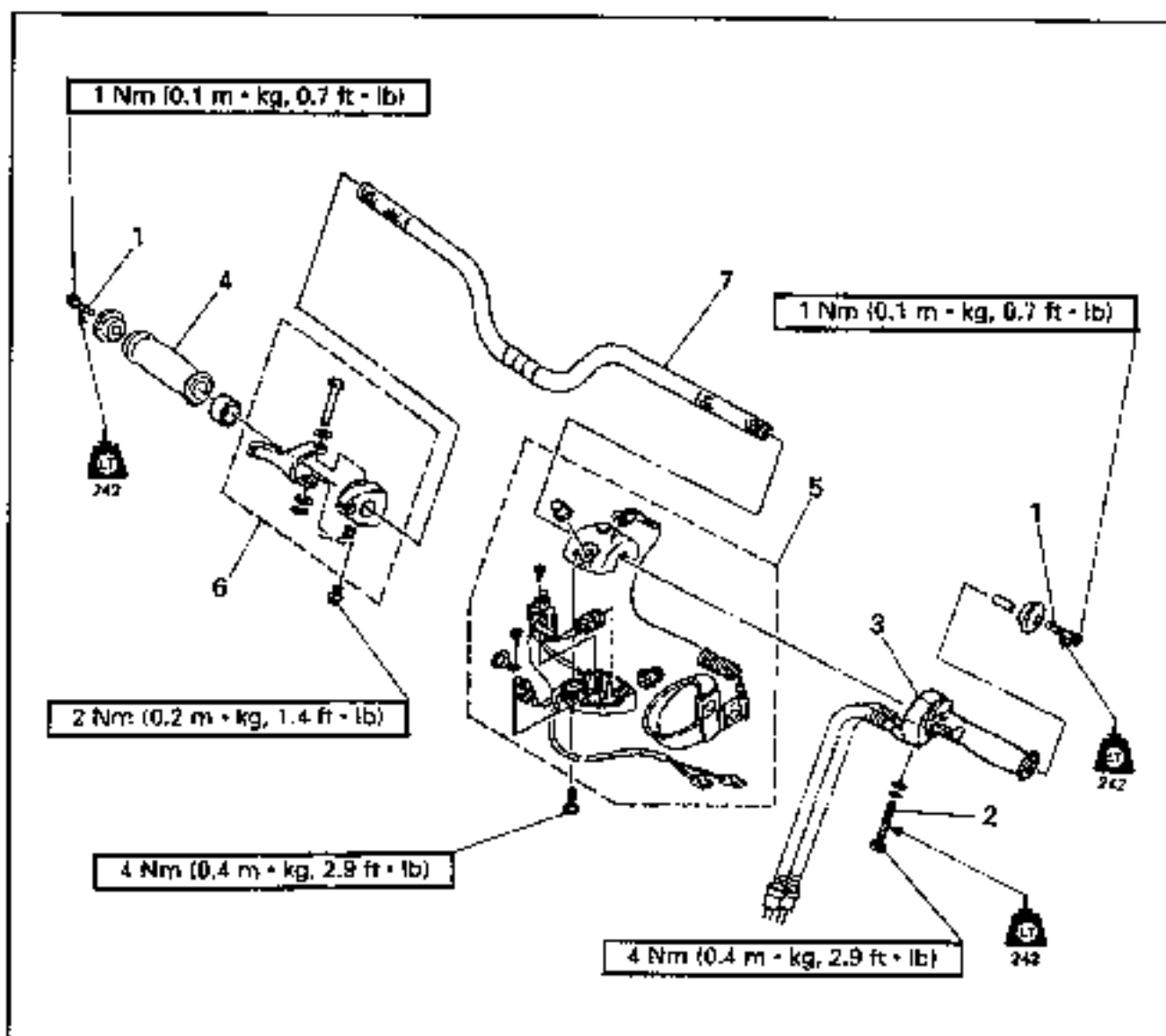

**REMOVAL AND INSTALLATION CHART**

Step	Procedure/Part name	Q'ty	Service points
<b>HANDLEBAR DISSEMBLY</b>			
	Handlebar assembly		Follow the left "Step" for removal. Refer to "HANDLE REMOVAL".
1	Bolt	2	
2	Screw	1	
3	Trim grip assembly	1	
4	Grip	1	<b>NOTE:</b> Apply adhesive to handlebar and inner surface of grip.
5	Handle switch assembly	1	
6	Throttle lever assembly	1	
7	Handlebar	1	
Reverse the removal steps for installation.			



**SERVICE POINTS**

**Handle inspection**

1. Inspect:
  - Handlebar  
Bend/Crack/Damage → Replace.

**Handle switch inspection**

Refer to "STARTING SYSTEM" in chapter 7.

**Handle switch installation**

1. Install:
  - Handle switch

**NOTE:**

Tighten the screw 1 on the stop button side first. Then, tighten the other screw 2.

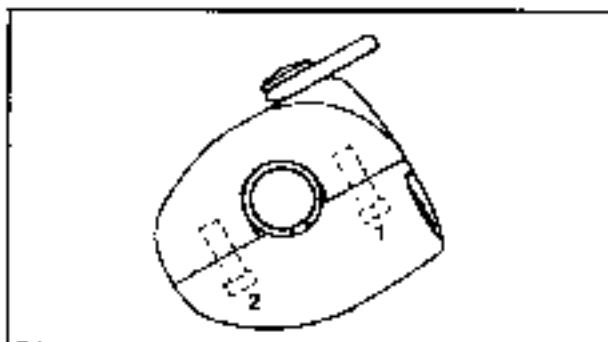



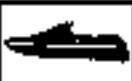

**TRIM GRIP AND CONTROL CABLE  
EXPLODED DIAGRAM**

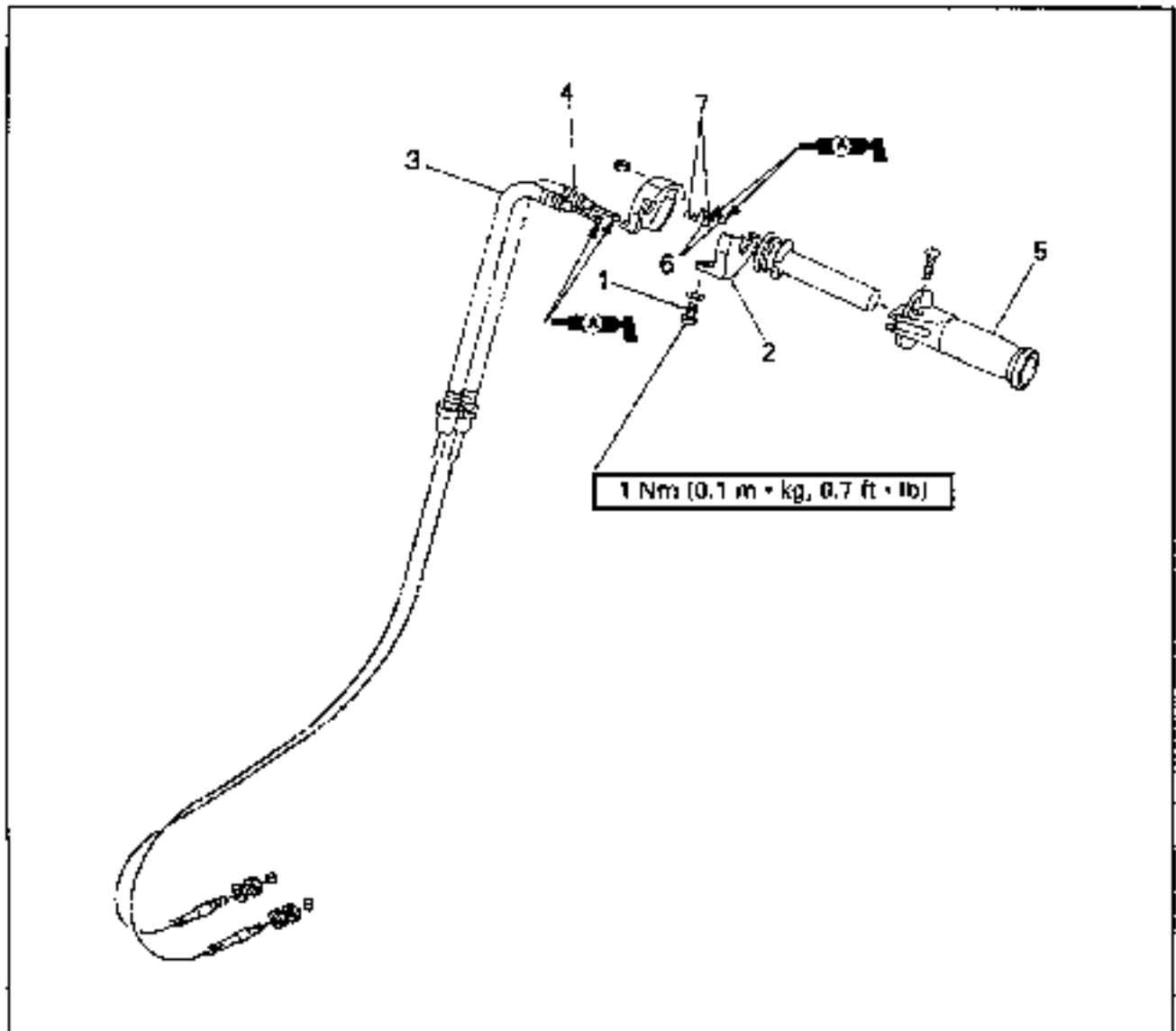

**REMOVAL AND INSTALLATION CHART**

Step	Procedure/Part name	Q'ty	Service points
	<b>TRIM GRIP AND CONTROL CABLE REMOVAL</b>		Follow the left "Step" for removal.
	Trim grip assembly		Refer to "HANDLE".
1	Screw	1	
2	Plate	1	
3	Trim control cable 1	1	
4	Trim control cable 2 (white taped)	1	
5	Grip	1	
6	Ball	2	
7	Spring	2	
			Reverse the removal steps for installation.

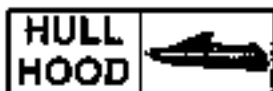

## TRIM GRIP AND CONTROL CABLE

---

E

### SERVICE POINTS

#### Trim control cable inspection

1. Inspect:
  - Trim control cable  
Kink/Fray/Stick → Replace.

#### Grip guide inspection

1. Inspect:
  - Grip guide  
Wear/Damage → Replace.



ENGINE HOOD COVER  
EXPLODED DIAGRAM

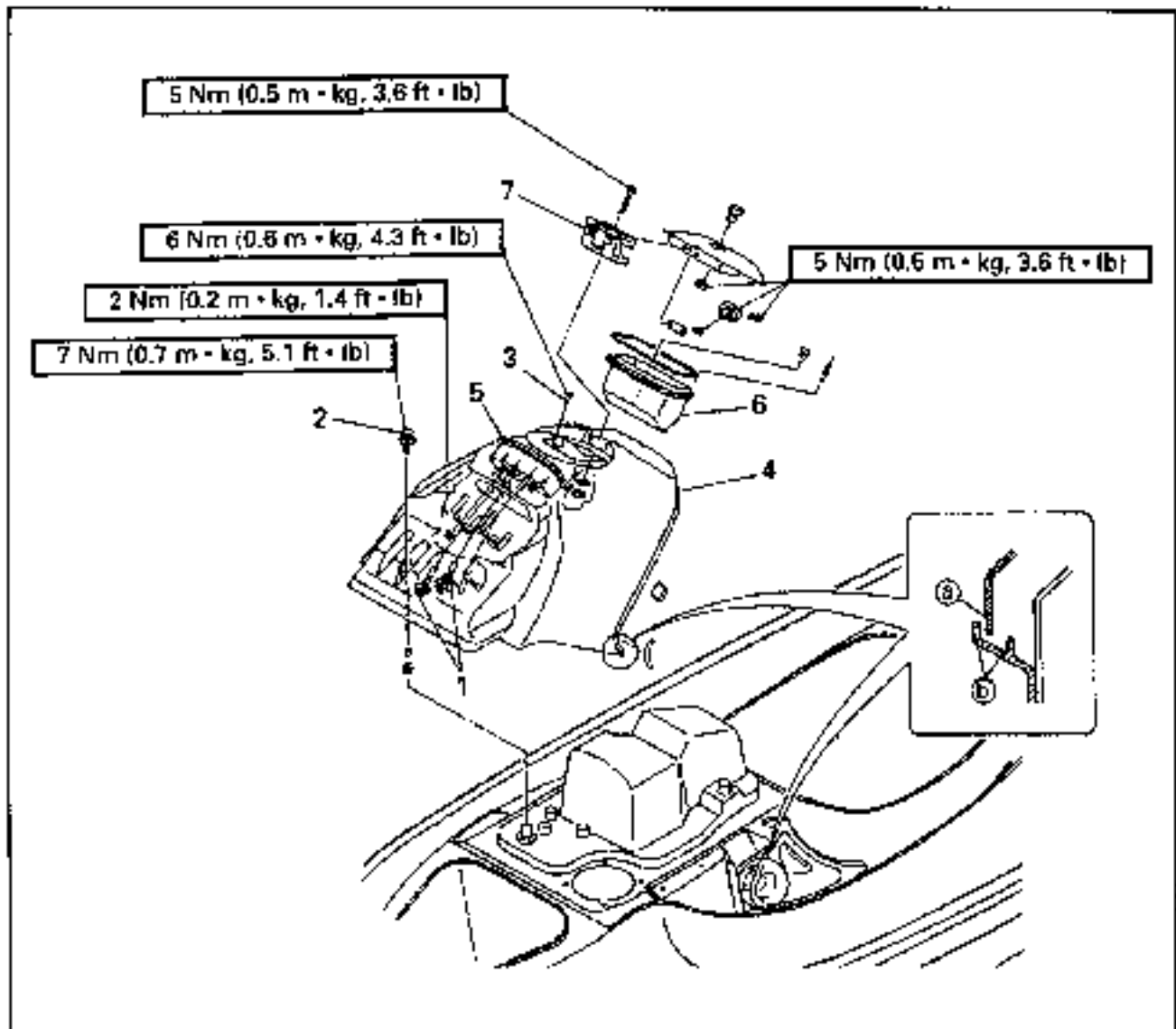

REMOVAL AND INSTALLATION CHART

Step	Procedure/Part name	Q'ty	Service points
	<b>ENGINE HOOD COVER REMOVAL</b>		Follow the left "Step" for removal. Refer to the "HANDLE REMOVAL".
1	Handlebar assembly	7	
2	Multi function meter coupler	1	
3	Bolt (with washer)	1	<b>NOTE:</b>
4	Screw	2	● Put the ends (a) of the engine hood cover between the flanges (b) of the side covers.
5	Engine hood cover assembly	1	● Install the engine hood cover with its three installation holes aligned with the corresponding holes in the engine hood.
6	Multi function meter	1	
7	Glove box	1	
7	Hinge	1	Reverse the removal steps for installation.

**HANDLE COLUMN  
EXPLODED DIAGRAM**

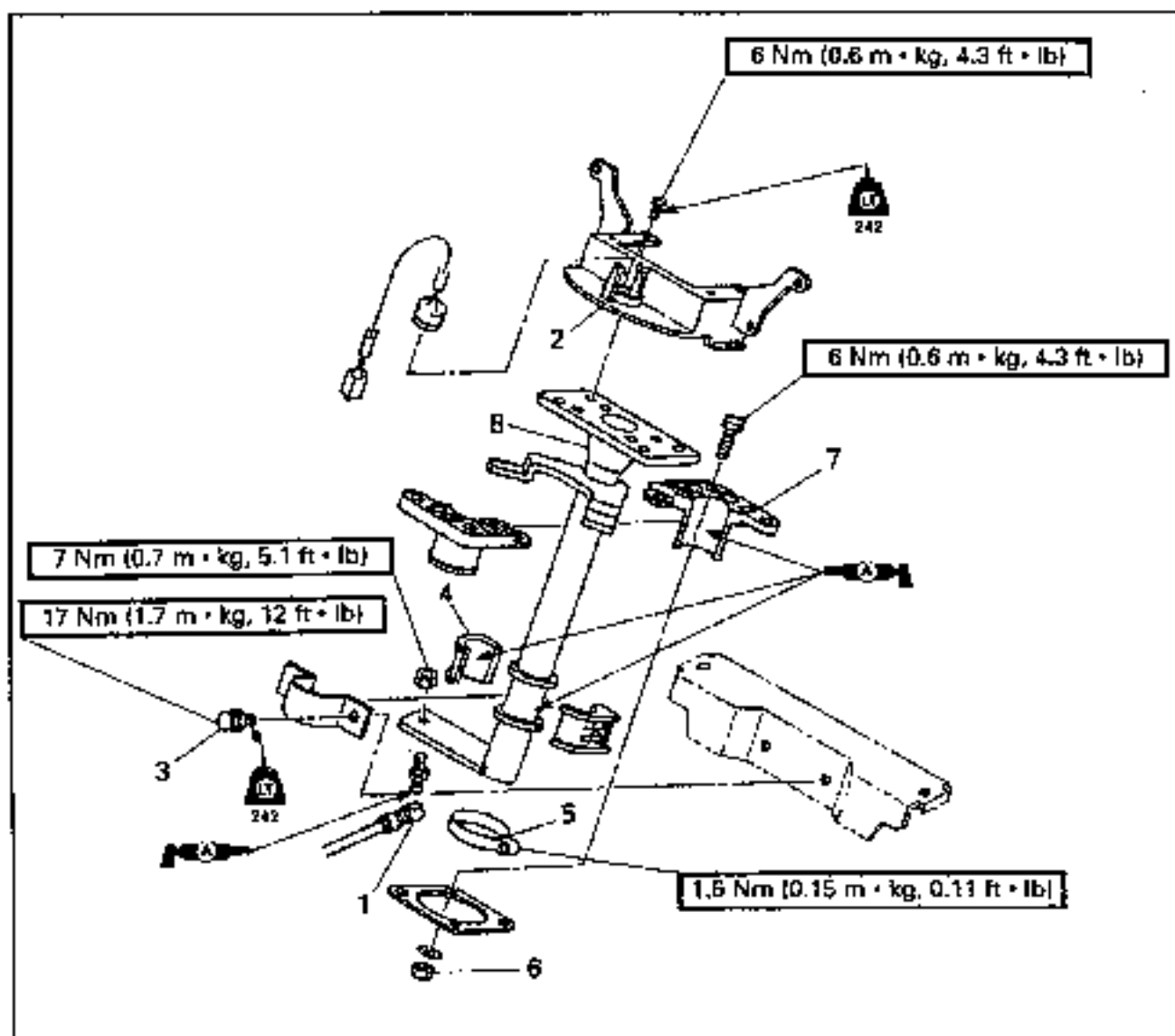

**REMOVAL AND INSTALLATION CHART**

Step	Procedure/Part name	Q'ty	Service points
	<b>HANDLE COLUMN REMOVAL</b>		Follow the left "Step" for removal. Refer to "ENGINE HOOD COVER".
	Engine hood cover assembly		
1	Steering cable	1	
2	Steering pad fixation	1	
3	Bolt (with washer)	2	
4	Steering bushing	2	
5	Clamp	1	
6	Nylon nut	4	
7	Column bushing	2	
8	Handle column	1	
			Reverse the removal steps for installation.



### SERVICE POINTS

#### Bushing inspection

1. Inspect:
  - BushingWear/Damage → Replace.

#### Handle column inspection

1. Inspect:
  - Handle columnBend/Crack/Damage → Replace.

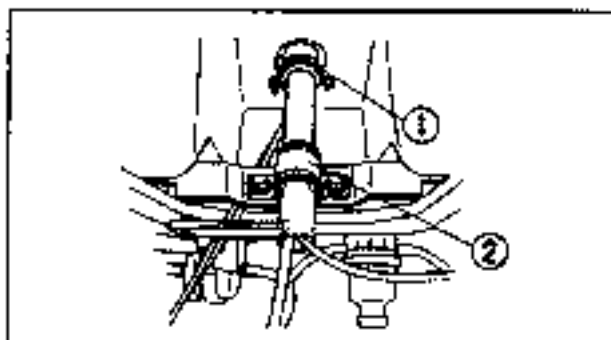

#### Bushing joint installation

1. Install:
  - Clamp (1)
  - Bushing joint (2)

#### NOTE:

Check for smooth action of the handle column when tightening the bolt.



**ADJUSTABLE MIRROR AND ENGINE HOOD REMOVAL  
EXPLODED DIAGRAM**

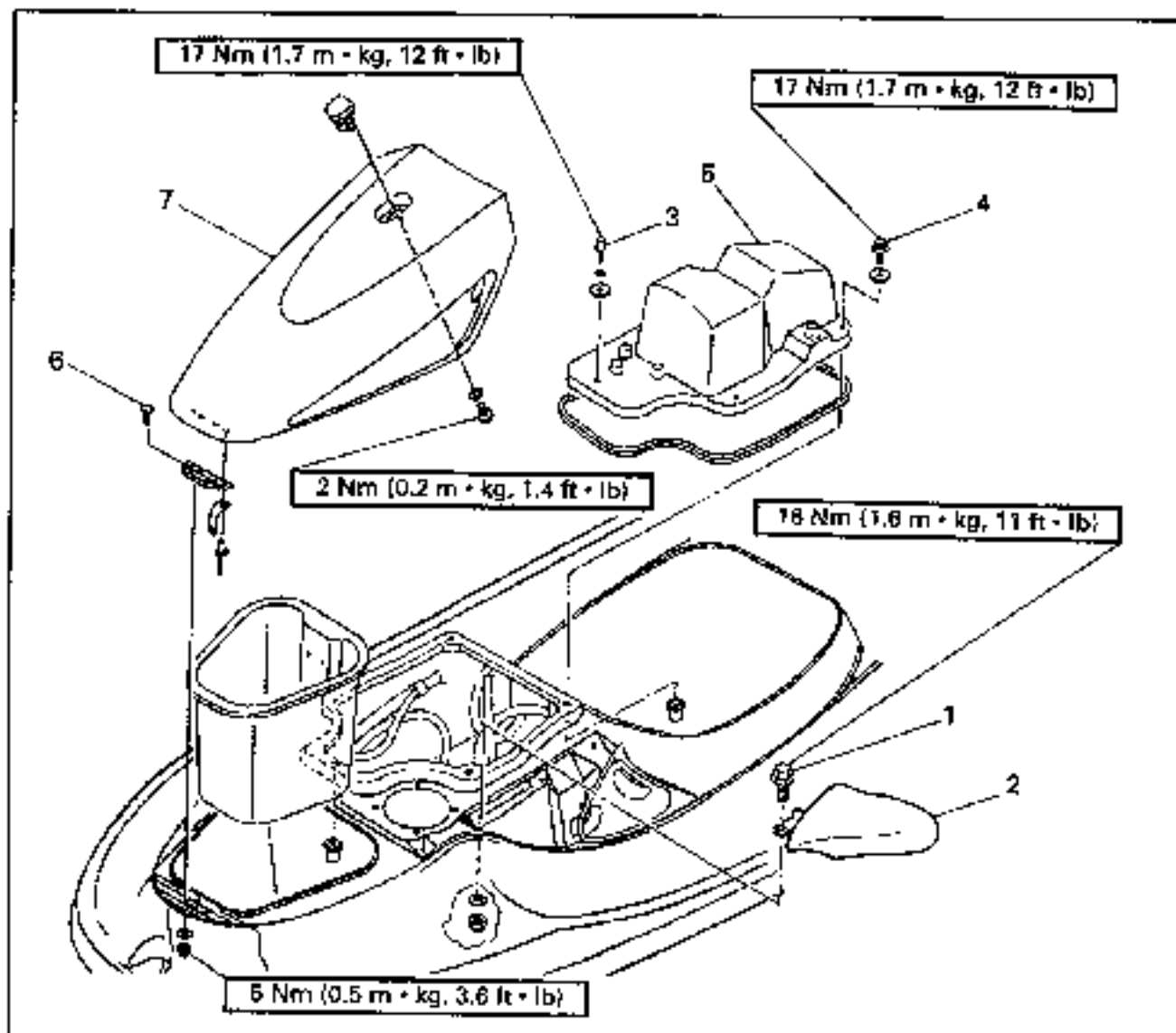

**REMOVAL AND INSTALLATION CHART**

Step	Procedure/Part name	Q'ty	Service points
<b>ADJUSTABLE MIRROR REMOVAL</b>			
	Engine hood cover assembly	1 ea, 1200	Follow the left "Step" for removal.
1	Bolt (with washer)	-, 4	Refer to "ENGINE HOOD COVER".
2	Adjustable mirror	-, 2	
<b>ENGINE HOOD REMOVAL</b>			
3	Bolt (with washer)	1	Reverse the removal steps for installation
4	Bolt (with washer)	4	
5	Engine hood assembly	1	
6	Screw	2	
7	Lid	1	

**ENGINE HOOD  
EXPLODED DIAGRAM**

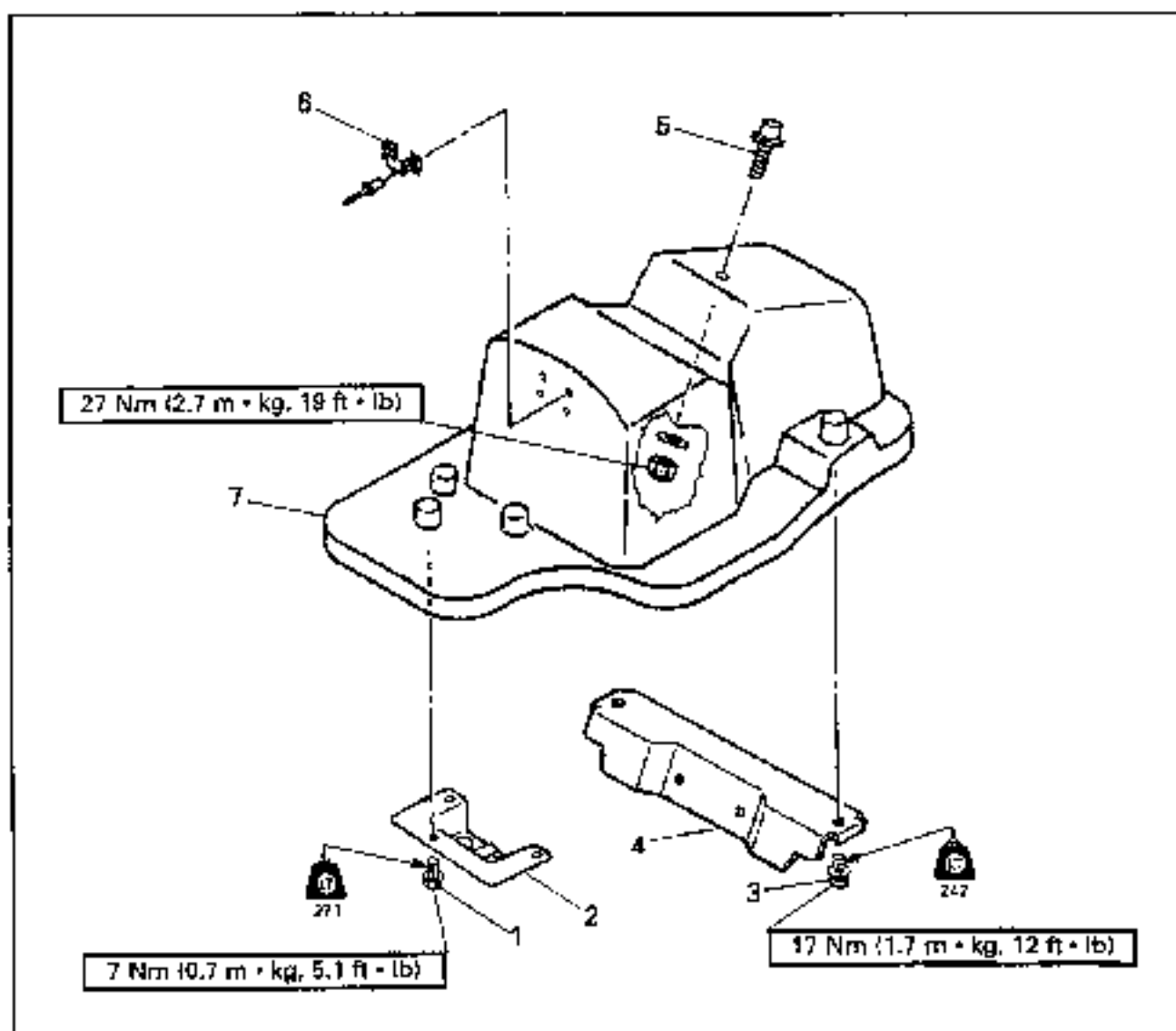

**REMOVAL AND INSTALLATION CHART**

Step	Procedure/Part name	Qty	Service points
	<b>ENGINE HOOD DISASSEMBLY</b>		Follow the left "Step" for removal. Refer to "ADJUSTABLE MIRROR AND ENGINE HOOD REMOVAL".  Reverse the removal steps for installation.
	Engine hood assembly		
1	Bolt (with washing)	3	
2	Cable bracket	1	
3	Bolt (with washing)	2	
4	Handle column bracket	1	
5	Steering stopper	1	
6	Lid lock hook	1	
7	Engine hood	1	

**STEERING CABLE  
EXPLODED DIAGRAM**

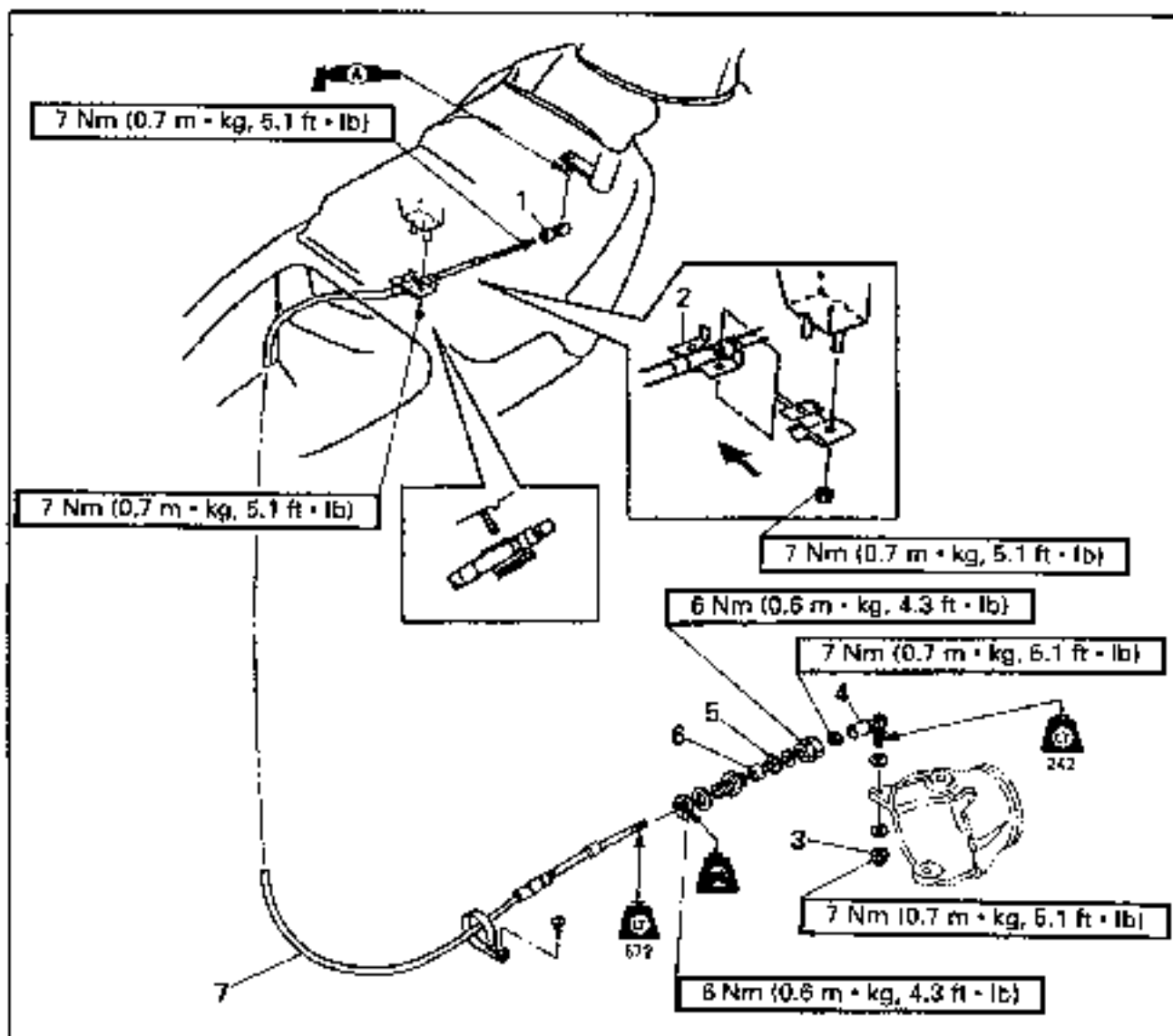

**REMOVAL AND INSTALLATION CHART**

Step	Procedure/Part name	Qty	Service points
<b>STEERING CABLE REMOVAL</b>			
1	Ride plate	1	Follow the left "Step" for removal. Refer to the "JET PUMP UNIT REMOVAL".
2	Cable joint	1	
	Cable stopper	1	<p><b>⚠ WARNING</b></p> <p>Be sure to fit the projection on the cable stopper into the groove in the outer cable.</p>
3	Nylon nut	1	
4	Cable joint	1	
5	Stopper	1	
6	Seal	1	
7	Steering cable	1	



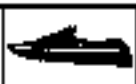

**SERVICE POINTS**

**Cable inspection**

1. Inspect:
  - Steering cable
  - Kink/Fray/Slick → Replace.

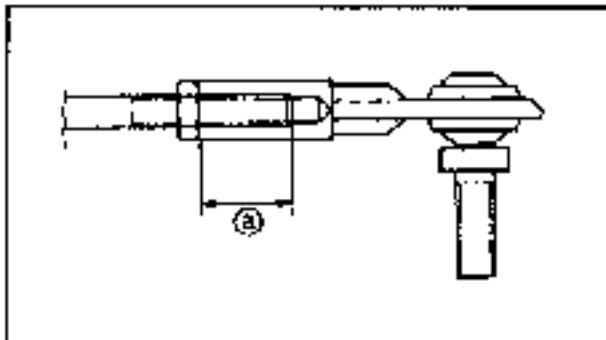

**Jet pump side cable joint installation**

1. Install:
  - Cable joint



**Cable joint set length (a):**  
13.7 - 15.3 mm (0.53 - 0.60 in)

**⚠ WARNING**

The cable joint must be screwed in more than 8 mm (0.31 in).

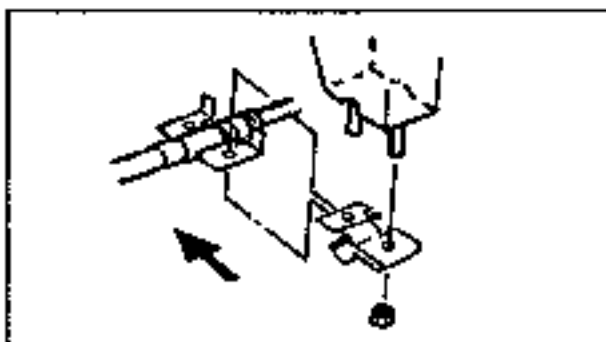

**Cable stopper installation**

1. Install:
  - Cable stopper

**NOTE:**

Install the cable stopper onto the studs of the cable bracket and hand tighten the nylon nuts. Gently move the cable back and forth until you feel the projection on the bracket fit into the groove on the outer cable, then tighten the nuts securely.

**Steering cable adjustment**

Refer to "CONTROL SYSTEM" in chapter 3.

**THROTTLE CABLE AND CHOKE CABLE  
EXPLODED DIAGRAM**

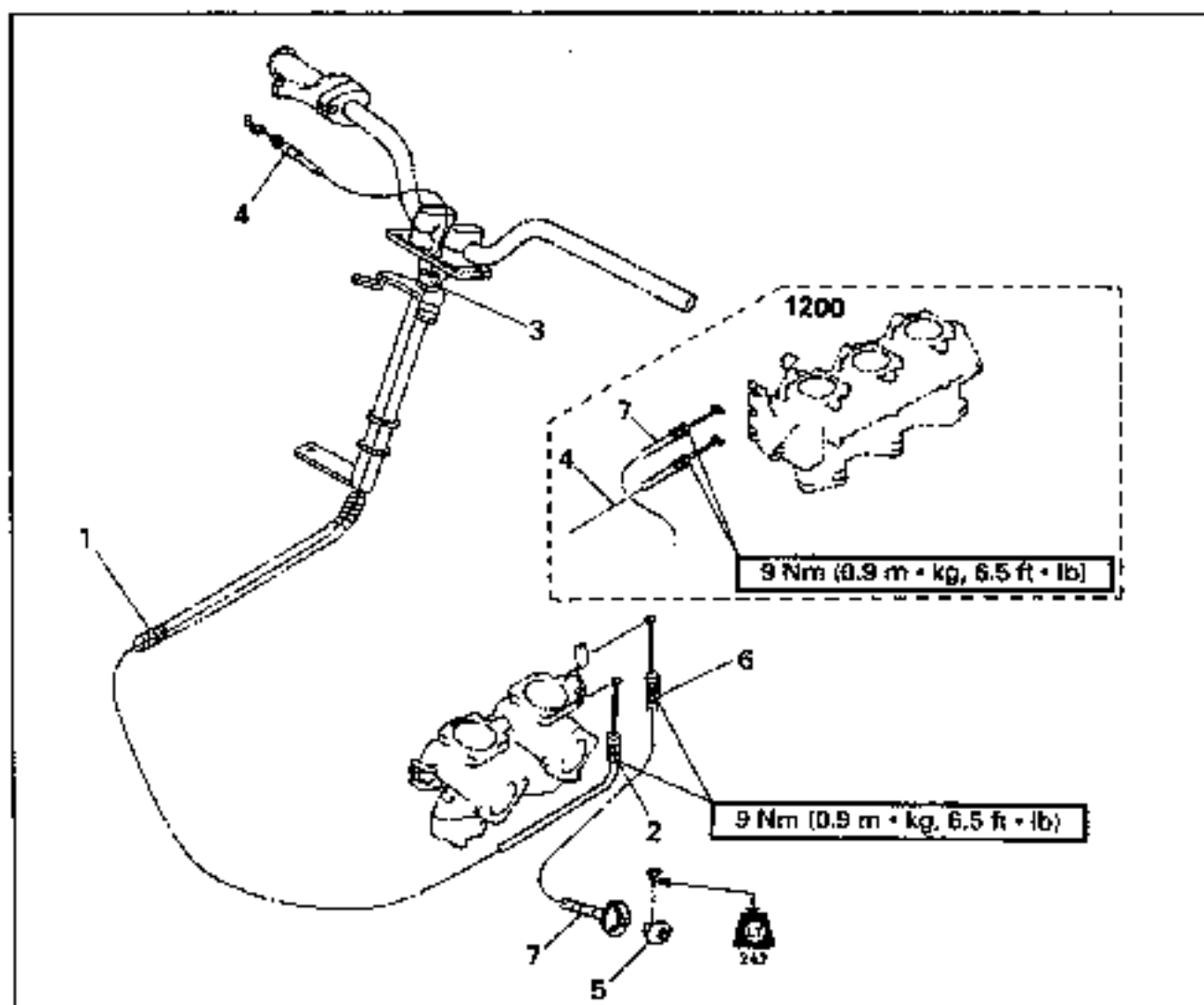

**REMOVAL AND INSTALLATION CHART**

Step	Procedure/Part name	Q'ty	Service points
<b>THROTTLE CABLE REMOVAL</b>			Follow the left "Step" for removal.
1	Spiral tube	1	
2	Throttle cable lock nut	1	
3	Seal packing	1	
4	Throttle cable	1	
<b>CHOKE CABLE REMOVAL</b>			Reverse the removal steps for installation.
5	Choke knob	1	
6	Choke cable lock nut	1	
7	Choke cable	1	

**SERVICE POINTS**

**Cable inspection**

1. Inspect:
  - Throttle cable
  - Choke cable
 Kink/Fray/Stick → Replace.

**Cable installation**

1. Install:
  - Cable guide

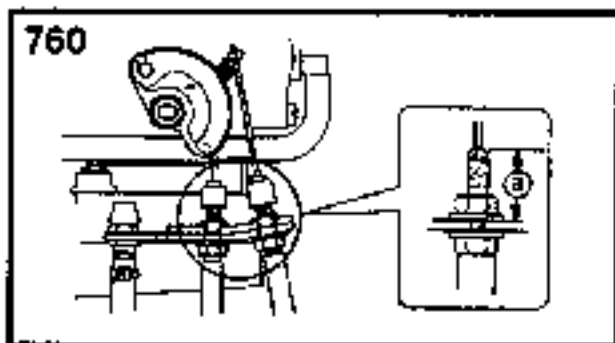

 **Cable guide set position ③:**  
 GP760:  
 17 mm (0.67 in)  
 GP1200:  
 Throttle cable: 17 mm (0.67 in)  
 Choke cable: 14 mm (0.55 in)

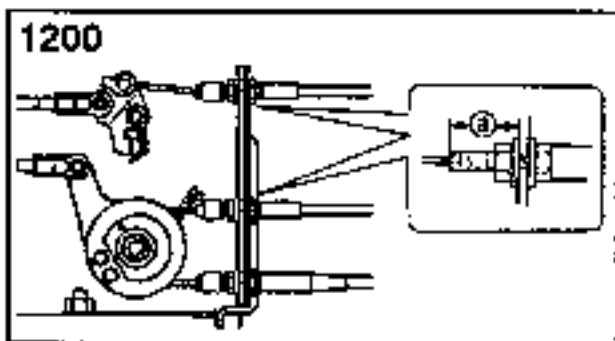

2. Install:
  - Seal packing
 Refer to "HANDLE REMOVAL".

**Throttle cable adjustment**

Refer to "CONTROL SYSTEM" in chapter 3.

**Choke cable adjustment**

Refer to "CONTROL SYSTEM" in chapter 3.

**TRIM CABLE  
EXPLODED DIAGRAM**

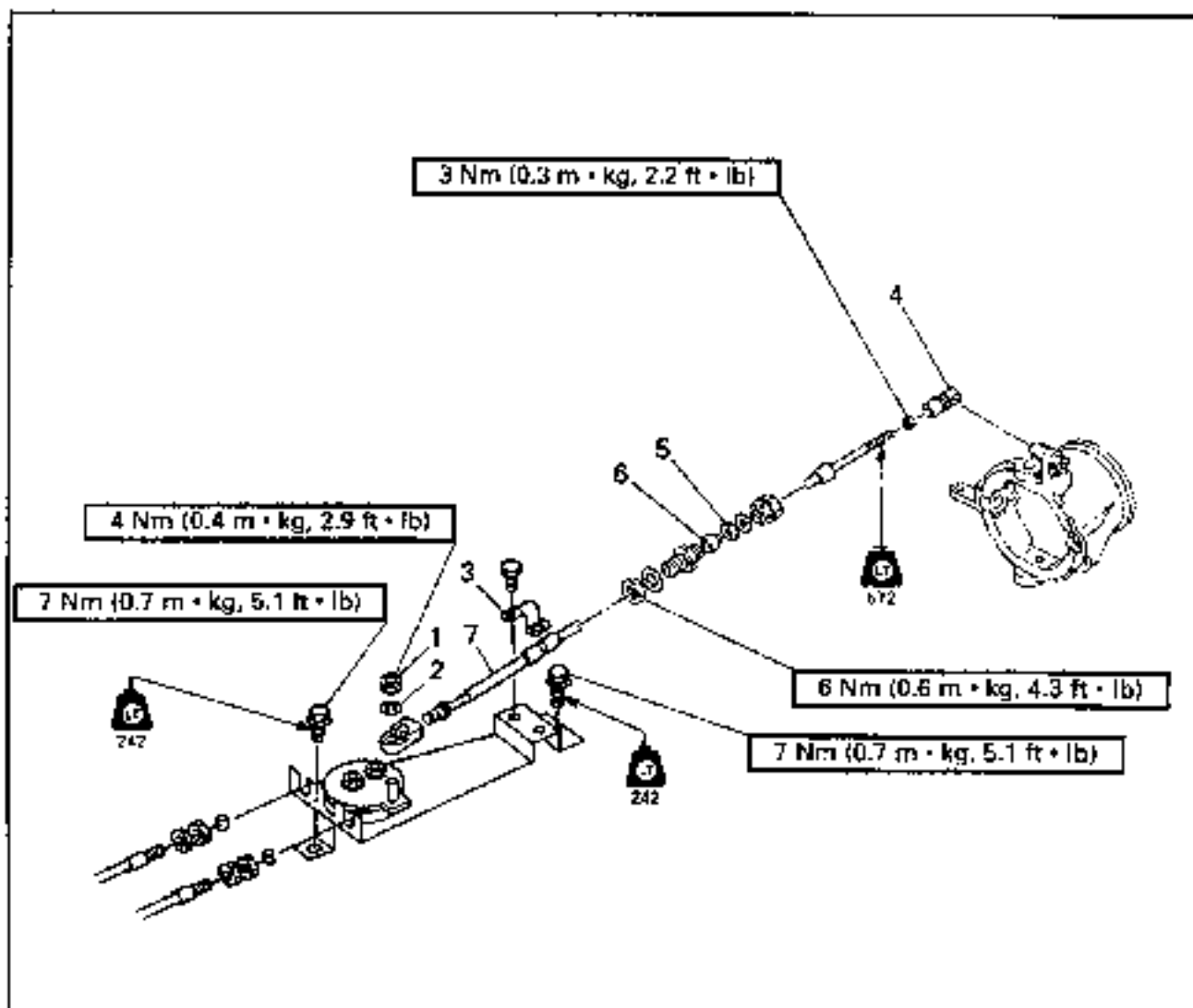

**REMOVAL AND INSTALLATION CHART**

Step	Procedure/Part name	Q'ty	Service points
	<b>TRIM CABLE REMOVAL</b>		
	Ride plate		Follow the left "Step" for removal. Refer to "JET PUMP UNIT REMOVAL".
1	Nylon nut	1	
2	Cable joint	1	
3	Cable stopper	1	<b>⚠ WARNING</b> Be sure to fit the projection on the cable stopper into the groove in the outer cable.
4	Cable joint	1	
5	Stopper	1	
6	Seal	2	
7	Trim cable	1	
			Reverse the removal steps for installation.

**SERVICE POINTS****Cable Inspection**

1. Inspect:
  - Trim cableKink/Fray/Stick → Replace.

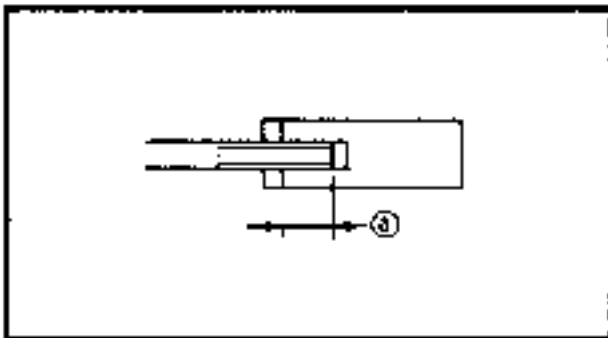
**Jet pump side cable joint installation**

1. Install:
  - Cable joint



**Cable guide set length (A):**  
12.8 - 14.4 mm (0.50 - 0.57 in)

**⚠ WARNING**

The cable joint must be screwed in more than 8 mm (0.31 in).

**Trim cable adjustment**

Refer to "CONTROL SYSTEM" in chapter 3.

**SEAT, STORAGE BOX AND BATTERY CASE  
EXPLODED DIAGRAM**

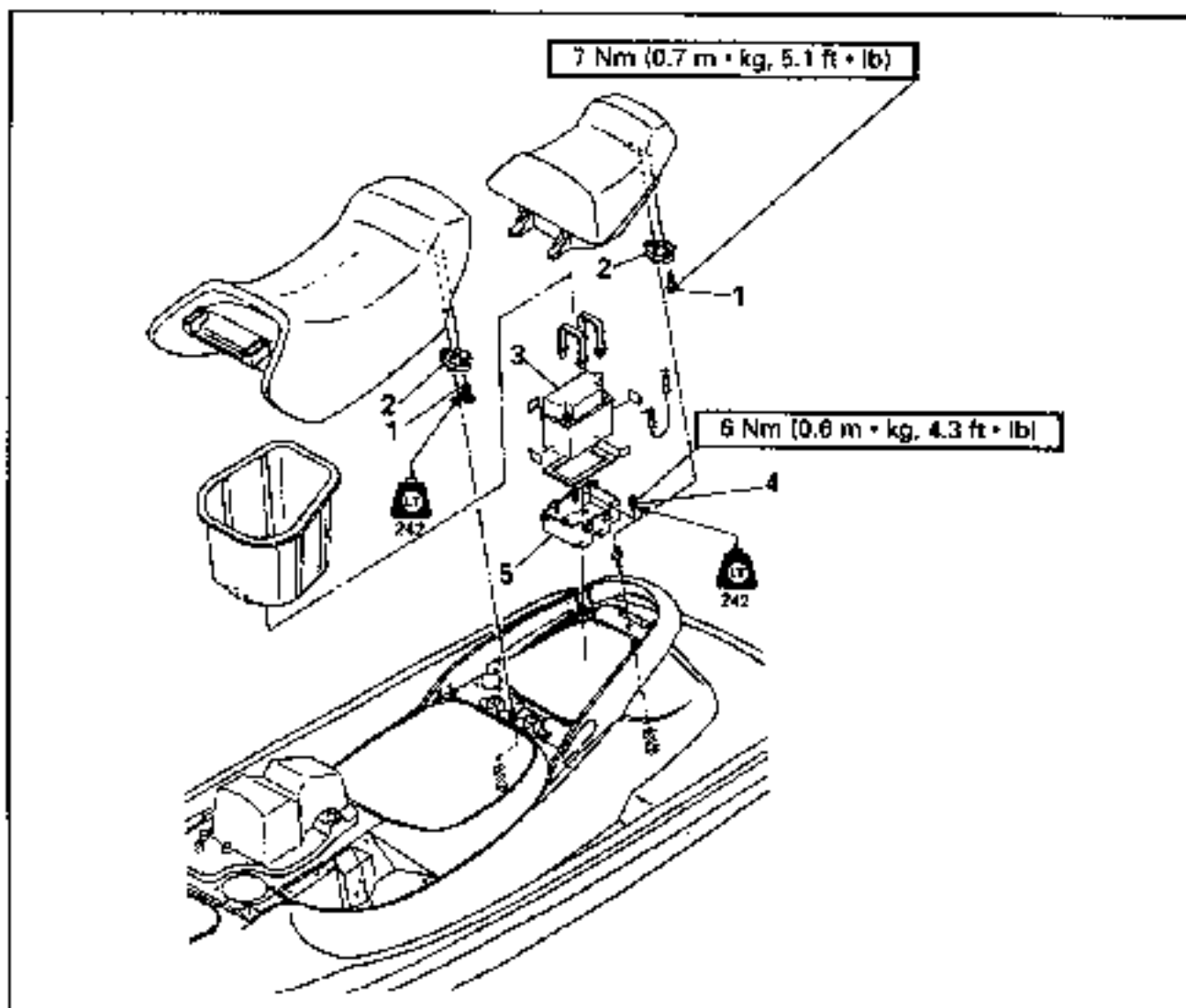

**REMOVAL AND INSTALLATION CHART**

Step	Procedure/Part name	Qty	Service points
	<b>SEAT, STORAGE BOX AND BATTERY CASE</b>		Follow the left "Step" for removal.
1	Screw	4	
2	Seat lock	2	
3	Battery	1	
4	Bolt (with washer)	4	
5	Battery case	1	
			Reverse the removal steps for installation.

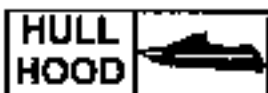

## SEAT, STORAGE BOX AND BATTERY CASE

E

### SERVICE POINTS

#### Seat inspection

1. Inspect:
  - Seat lock  
Wear/Damage → Replace.

#### Storage box inspection

1. Inspect:
  - Storage box  
Crack/Damage → Replace
  - Packing  
Flat/Damage → Replace.

#### Battery case inspection

1. Inspect:
  - Battery case  
Crack/Damage → Replace.
  - Packing  
Flat/Damage → Replace.

**EXHAUST SYSTEM  
EXPLODED DIAGRAM**

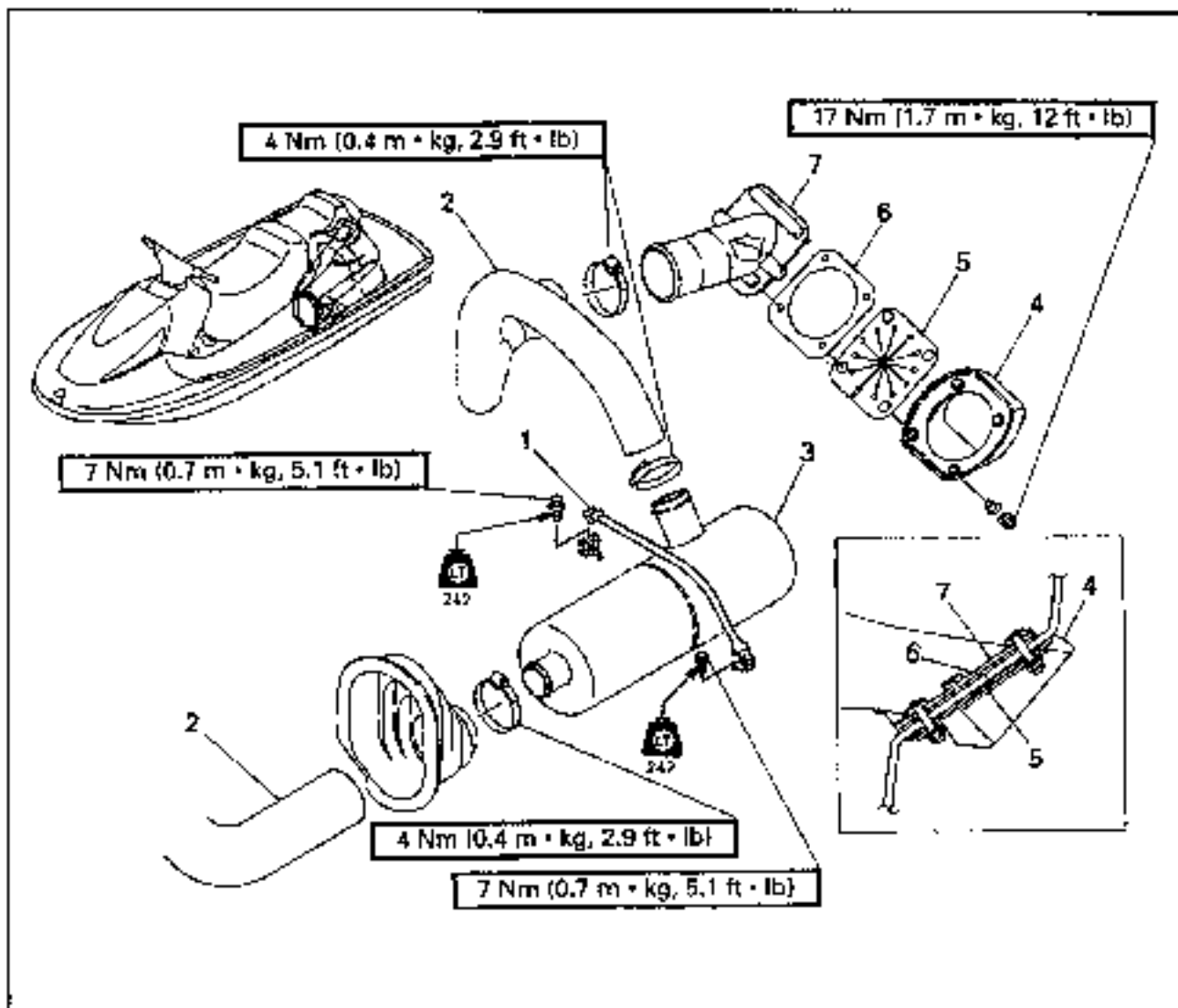

**REMOVAL AND INSTALLATION CHART**

Step	Procedure/Part name	Qty	Service points
	<b>EXHAUST SYSTEM REMOVAL</b>	763.1820	Follow the left "Step" for removal.
1	Band	1	
2	Exhaust hose	2	
3	Water lock	1	
4	Exhaust cover	1	
5	Exhaust valve	1	
6	Packing	1	
7	Exhaust guide	1	
			Reverse the removal steps for installation.





## EXHAUST SYSTEM

(E)

### SERVICE POINTS

#### Exhaust system inspection

1. Inspect:
  - Band  
Crack → Replace.
2. Inspect:
  - Exhaust hose  
Crack/Wear/Burn → Replace.
3. Inspect:
  - Water lock  
Crack/Leak → Replace.  
Gathered water → Drain.

**DECK  
EXPLODED DIAGRAM**

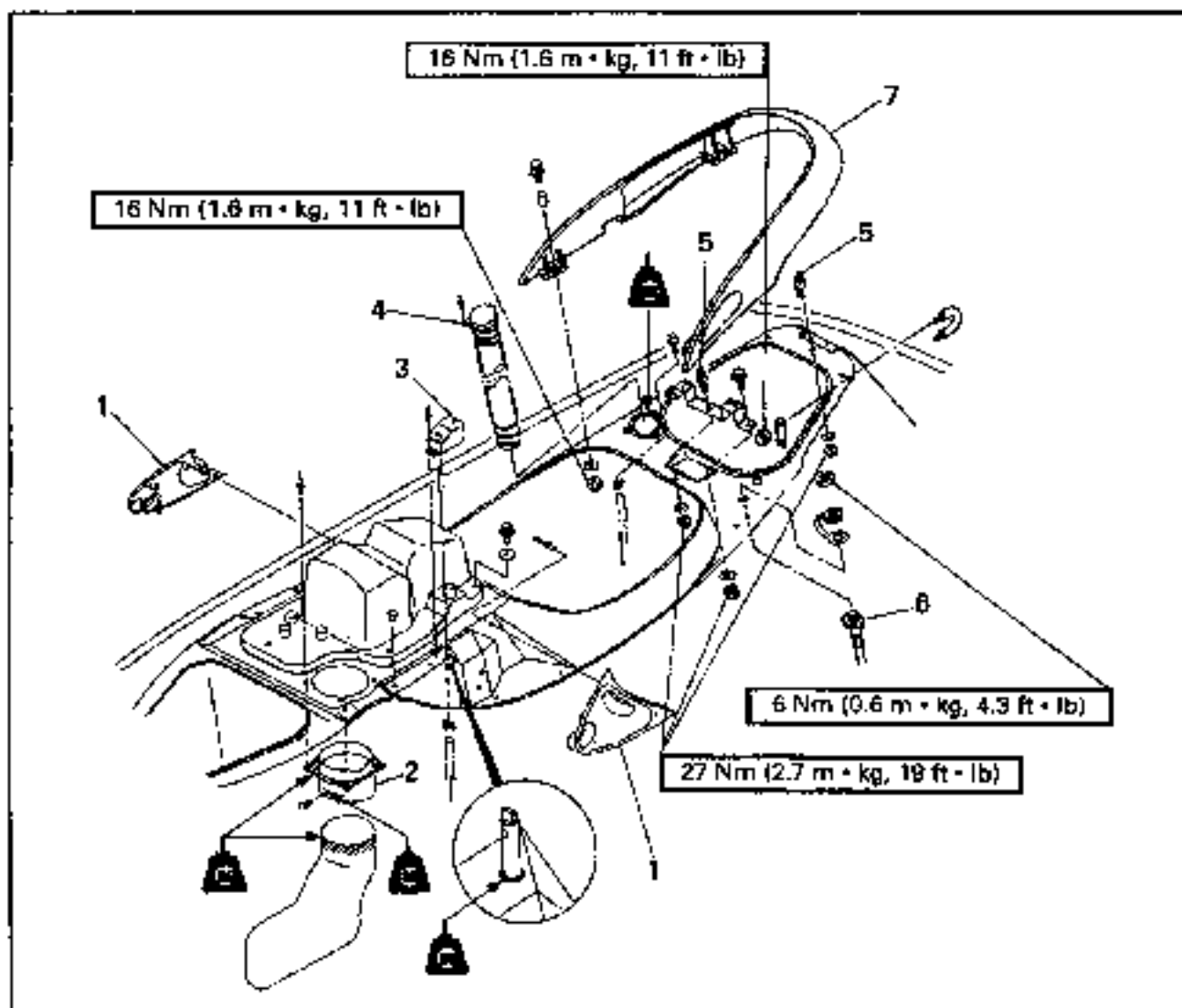

**REMOVAL AND INSTALLATION CHART**

Step	Procedure/Part name	Q'ty	Service points
<b>DECK DISASSEMBLY</b>			Follow the left "Step" for removal.
1	Side cover	2	
2	Ventilation base	1	
3	Ventilation socket	1	
4	Ventilation joint	1	
5	Seat lock pin	2	
6	Flushing hose	1	
7	Grip handle	1	Reverse the removal steps for installation.

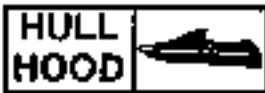

## DECK

E

### SERVICE POINTS

#### Ventilation system inspection

1. Inspect:

- Ventilation hose  
Wear/Crack → Replace.
- Ventilation hose joint  
Wear/Damage → Replace.

**GUNWALE  
EXPLODED DIAGRAM**

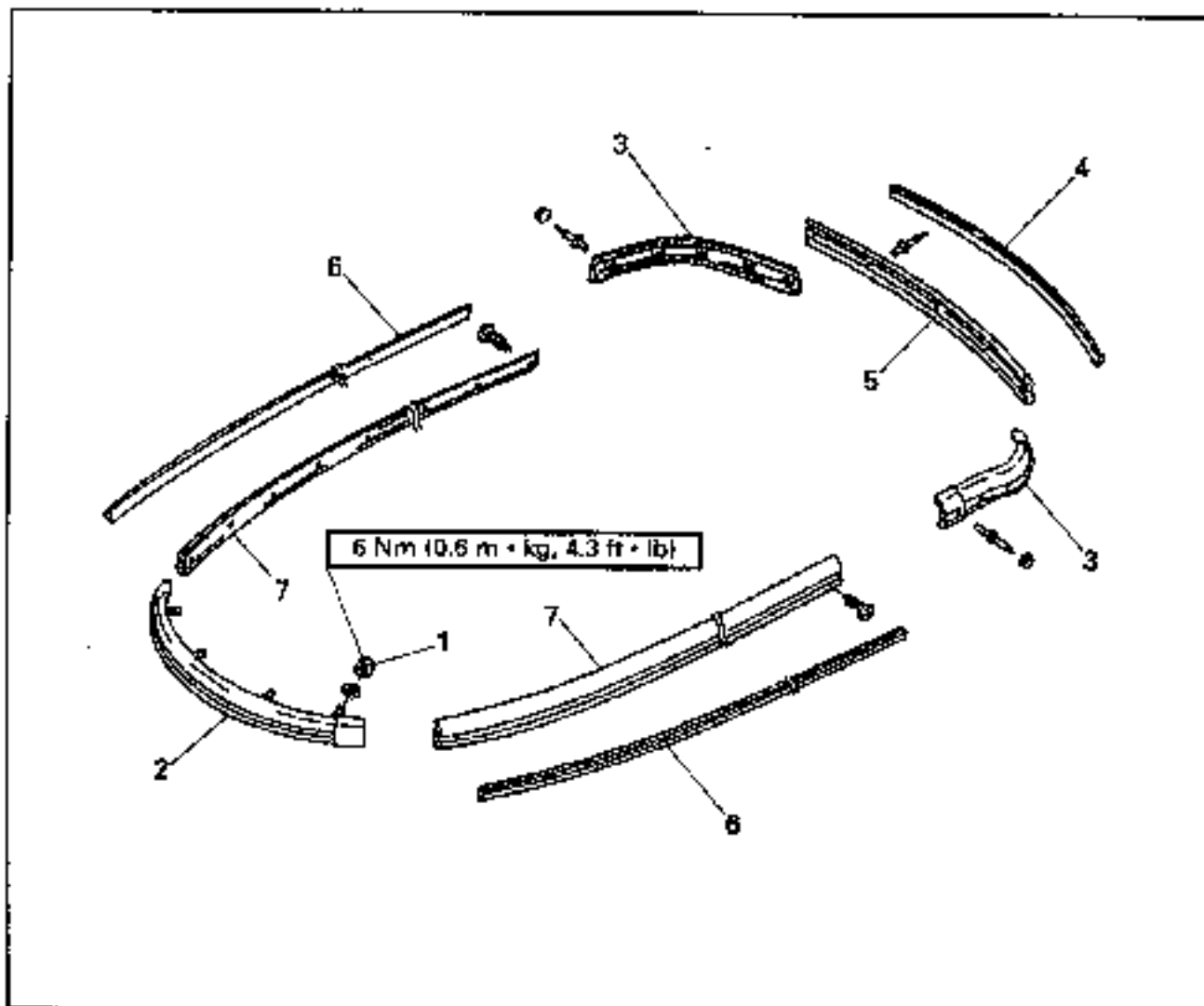

**REMOVAL AND INSTALLATION CHART**

Step	Procedure/Part name	Q'ty	Service points
	<b>GUNWALE REMOVAL</b>		Follow the left "Step" for removal.
1	Nylon nut	4	
2	Bow gunwale	1	
3	Stern gunwale	2	
4	Inner gunwale	1	
5	Cover gunwale	1	
6	Inner gunwale	2	
7	Side gunwale	2	
			Reverse the removal steps for installation.

**MAT**

**EXPLODED DIAGRAM**

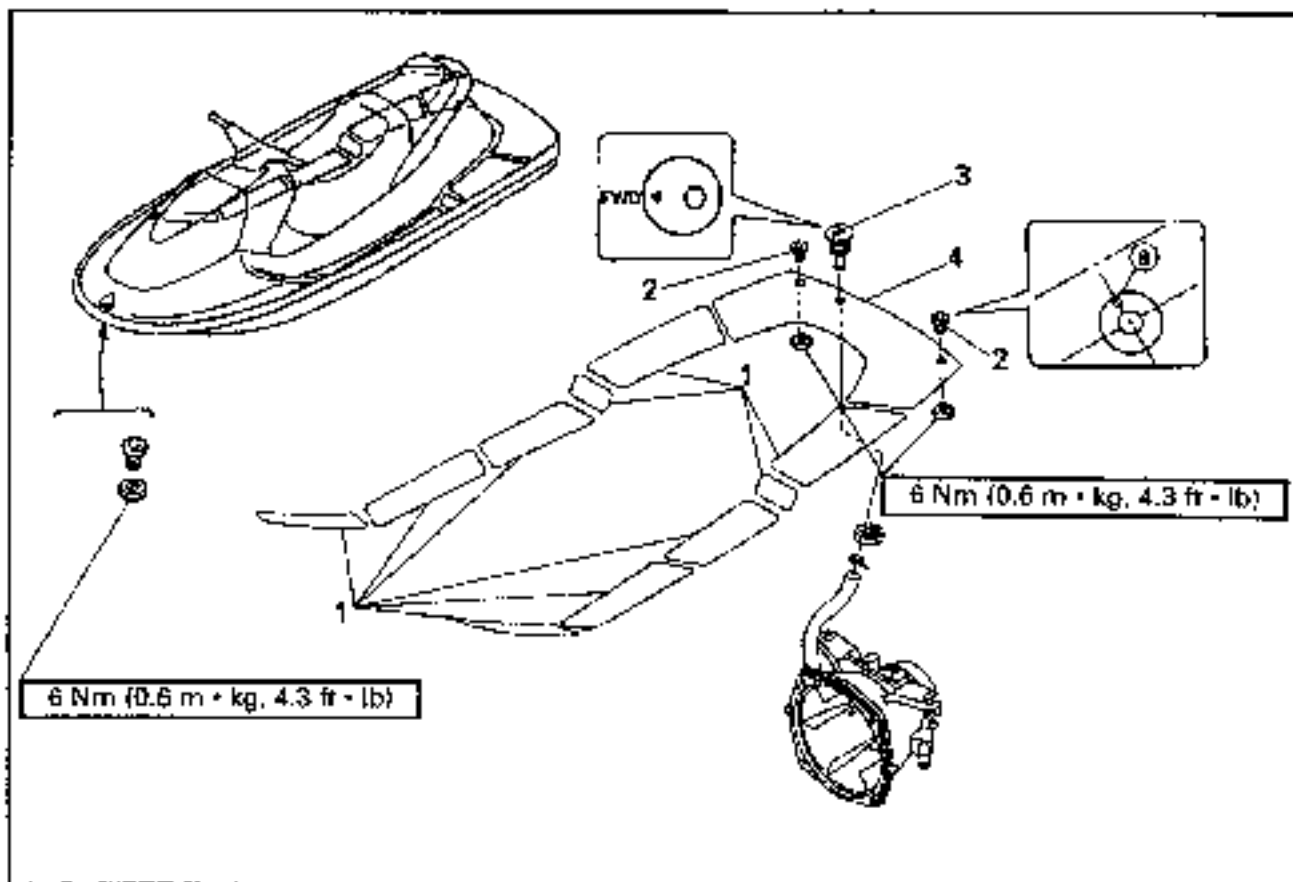

**REMOVAL AND INSTALLATION CHART**

Step	Procedure/Part name/s	Qty	Service points
	<b>MAT REMOVAL</b>		Follow the left "Step" for removal.
1	Step mat	10	
2	Rope hole bolt	3	<b>NOTE:</b> _____ The rope hole bolts should be installed with the projections  facing each other.
3	Spout	1	
4	Upper mat	1	Reverse the removal steps for installation.

**SERVICE POINTS**

**Mat installation**

- 1. Install:
  - Mat

**NOTE:** \_\_\_\_\_

- Clean the step surface before installing the mat.
- Apply cyano-acrylate adhesive on the mat.



HULL  
EXPLODED DIAGRAM

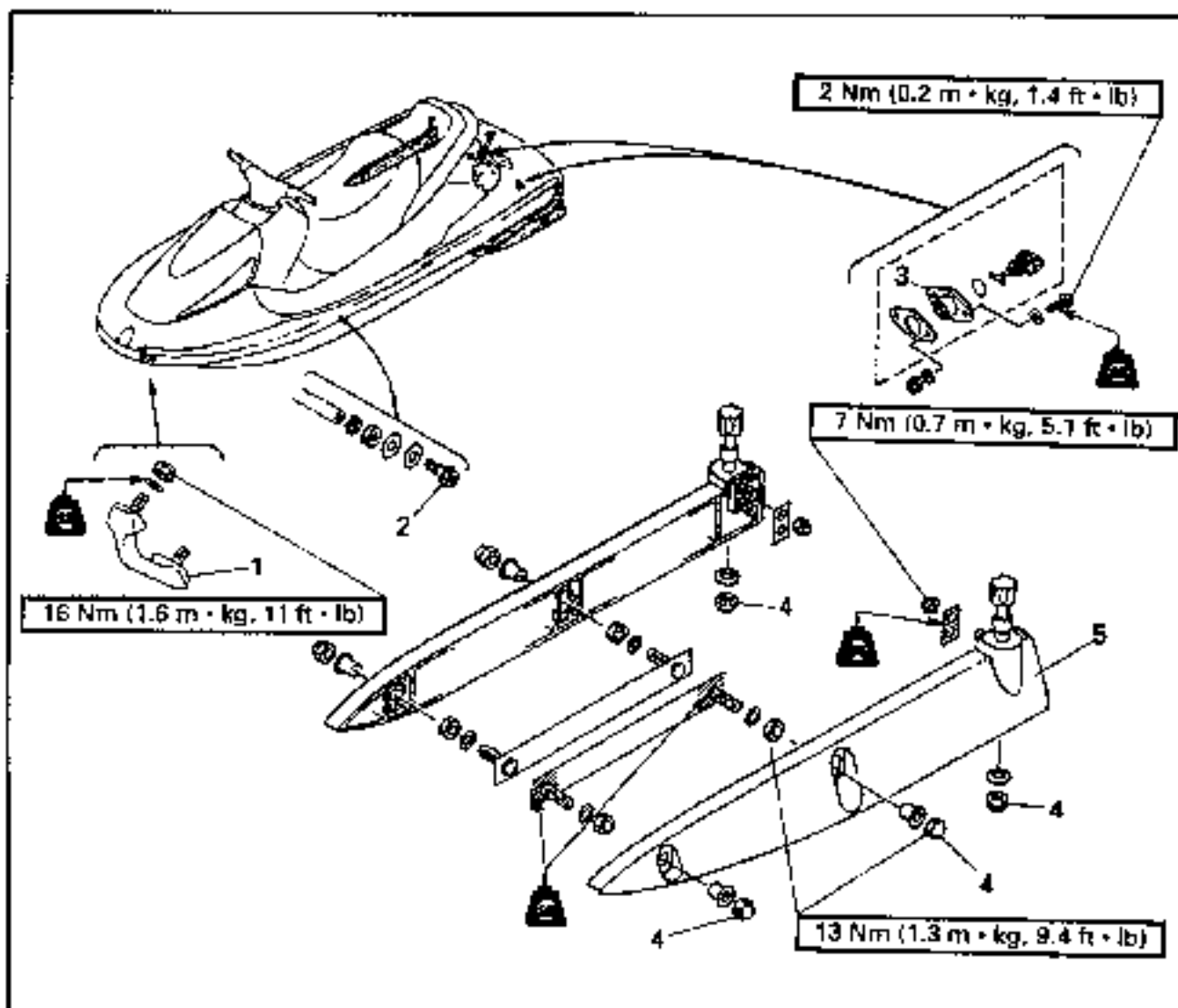

REMOVAL AND INSTALLATION CHART

Step	Procedure/Part name	Qty	Service points
	<b>HULL DISASSEMBLY</b>		Follow the left "Step" for removal.
1	Bow eye	1	
2	Pilot water outlet	1	
3	Drain plug socket	2	
4	Nylon nut	6	
5	Sponson	2	
			Reverse the removal steps for installation.

**HULL REPAIR**

**Light scratching**

1. Sand the scratched area smooth with #400 grit wet or dry paper, and then with #600 grit wet or dry paper.
2. Polish the area with rubbing compound and buff to a high gloss using a wool pad and automotive wax.

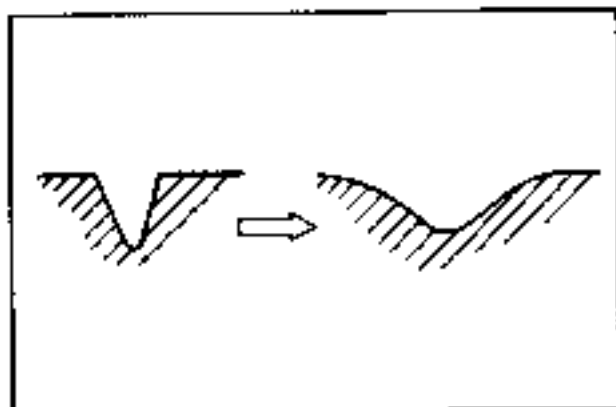

**Deep scratching**

1. Remove any sharp/rough edges from the surface.
2. Sand the area smooth for about one inch all around the scratch with #80 grit wet or dry paper.
3. Clean the area with acetone and dry it.
4. Mix gel-coat with gel-coat thickener to make gel-coat putty and then add the catalyst to make.
5. Apply and spread the catalyzed putty with a squeegee, then cover the putty with a piece of waxed paper.
6. When the putty has set, sand the area catalyzed putty. Smooth using #80 grit to #400 grit wet or dry paper and a sanding block.
7. Clean the area with a dry cloth and polish it.

**⚠ WARNING**

**Resin, catalyst and solvent are flammable and toxic. Use only in a well-ventilated area and keep away from open flames and sparks. Observe all warnings given by the manufacturer.**

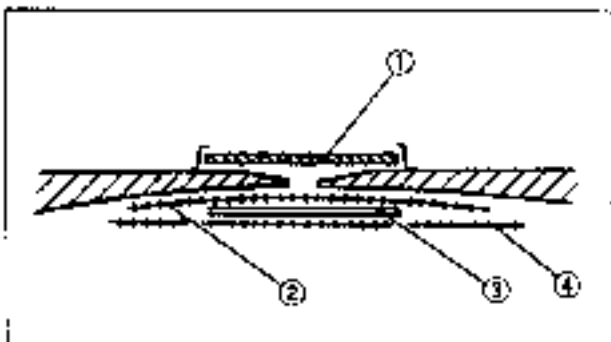
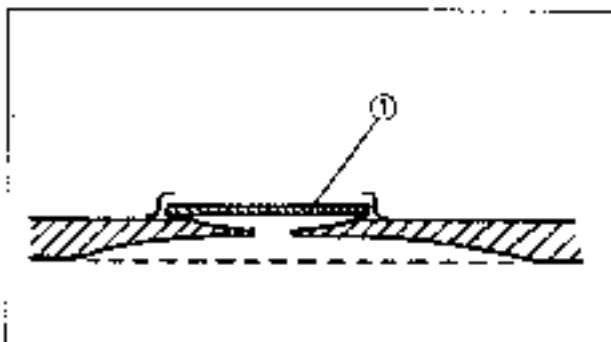
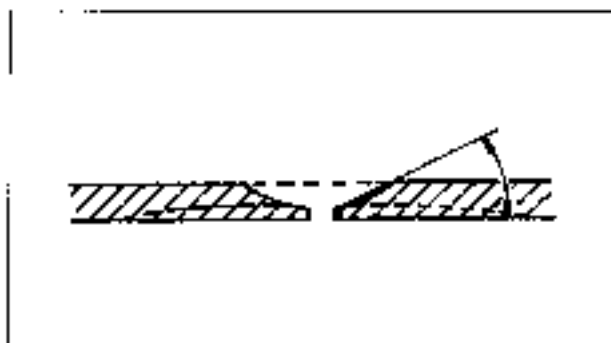
**Hull damage (punctured)**

1. Remove any damaged fiberglass.
2. Cut and open the crack approximately 1/4 inch.
3. Grind the opened edge less than 30° on the outside.
4. Grind the area from inside the hull approximately 4 inches beyond it.
5. Clean the area with acetone, apply BP-1 or an equivalent primer on both sides of the area and cure for 1/2 hour.
6. Tape a piece of cardboard covered with waxed paper ① over the damaged area.
7. Mix polyester resin and catalyst and apply it to the hull.
8. Apply a glass mat ② (2 inches smaller than the ground area).
9. Apply catalyzed resin.
10. Apply a 20 oz fiberglass cloth ③ (1 inch smaller than the glass mat).
11. Apply catalyzed resin.
12. Apply a final glass mat ④ (1 inch smaller than the ground area).
13. When the resin has hardened, remove the piece of cardboard.
14. Finish the outer surface using steps 3 - 7 in the "Deep scratching" section.

**NOTE:**

Refer to "WATER VEHICLE FRP REPAIR MANUAL".



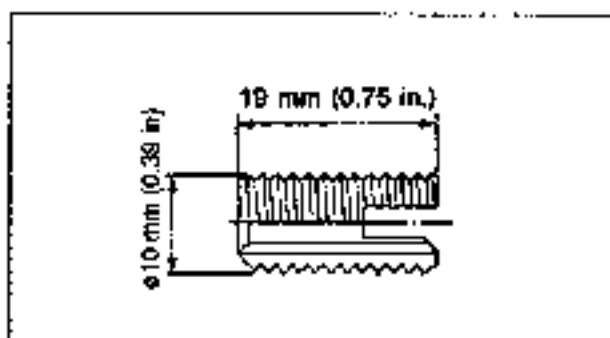
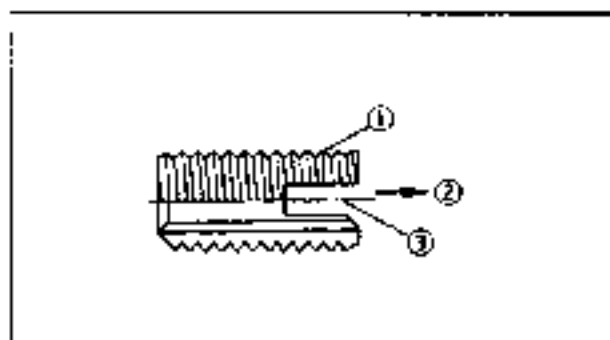

**Insert nut**

**NOTE:**

When a pop nut clinched to a hull slipped off or when a bolt fastened to an insert nut or pop nut was broken, use this insert nut.

Part No.	Part Name	Remarks
EW2-62733-09	Nut	Stainless steel, M6

- Nut ①
- Direction of thread ②
- Slot to be threaded ③

**NOTE:**

**Drilling size**

Material	Pilot hold diameter
FRP or SMC	9.1 ~ 9.2 mm (0.38 in)
Brass	9.4 mm (0.37 in)

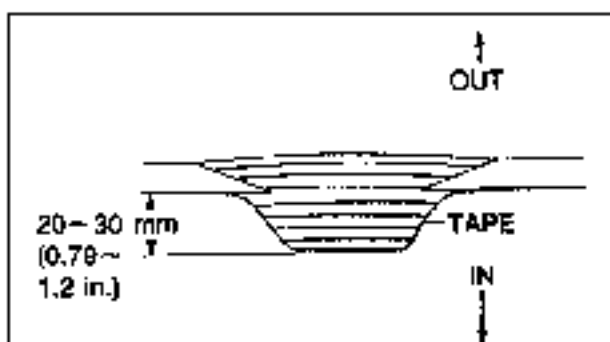
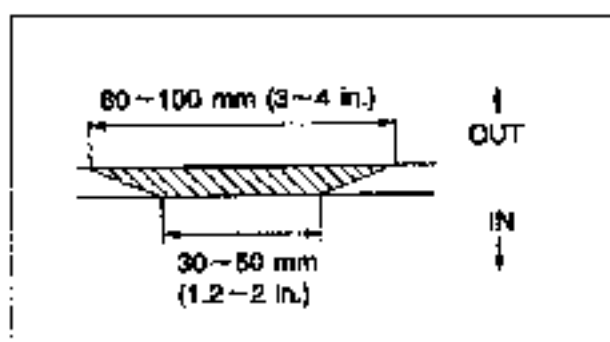

**Example 1:**

The nut is used to repair the pop nut designed for plate 2.

(by repairing the FRP portion, the new-type nut can be used for all models)

For details of repairs to the FRP portion, refer to the "Water Vehicle FRP Repair Manual".

1. Remove:
  - Pop nut
2. Scarf the shaded portion.
3. Clean the surface to be scarfed and the inside of the hull with acetone.
4. As shown, first tape up the inner surface of the hull and then laminate fiber-glass mats over the tape using a resin.

**NOTE:**

When it is possible to work inside the hull, the mats should be laminated from the inside.

5. Smooth out the out surface by sanding it.
6. Install plate 2. Then, using a 9.2 mm (0.36 in) diameter drill, make a hole of depth 20 mm (0.79 in) in the center of the laminated fiberglass layers.
7. Pass the bolt ① through the insert nut, as shown, and lock the bolt with the nut ②. Screw in the insert nut so that the top is flush with the FRP surface. Loosen the lock nut and remove the bolt.

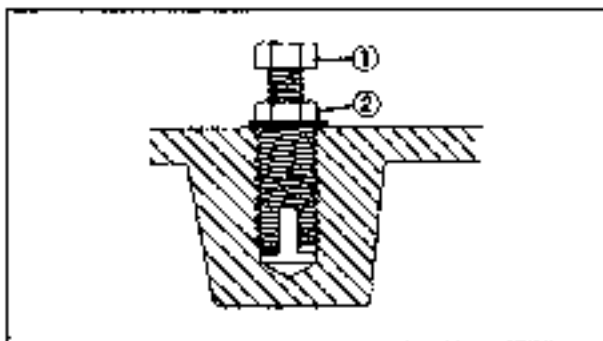

- The bolt should be made of steel and its strength should be BT or more.
- If the bolt is inferior in strength, or is made of stainless steel, it may break.

- Bolt ① <Strength is BT or more>
- Lock nut ②

**Example 2:**

The brass insert nut designed for the Super Jet Plate 2 or the screen intake is used:

1. If the bolt is broken, remove it using drills.

**NOTE:**

Use a small-diameter drill first, followed by drills of gradually increasing diameter.

2. Use a 9.4 mm (0.37 in) drill for the final drilling.
3. Apply silicone sealant to the inside of the hole so that no water can enter the urethane foam.
4. As in Example 1 above, screw in the insert nut.

- Brass insert ①
- Hull ②
- Urethane foam ③
- Silicone sealant ④

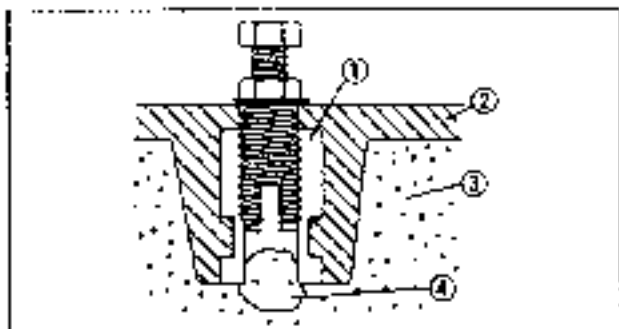

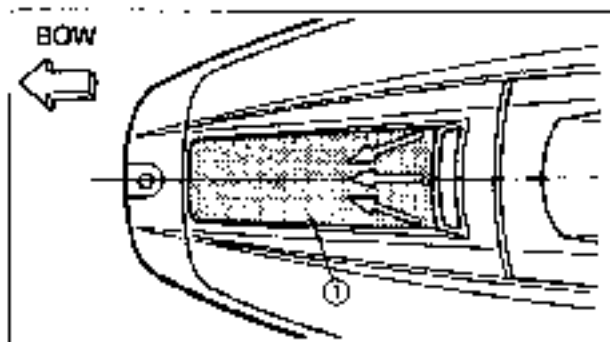

### Removing a graphic

1. Remove:
  - Graphic (1)

### NOTE:

Using a hair dryer, start at one corner and blow heat the graphic, holding the heat source at least 1-1/2" above the graphic.

Slowly peel off the heated part and continue working towards the other side.

- 2 Clean:

Once the graphic is removed, clean the entire bow area with Isopropyl Alcohol to remove any residual adhesive.

### Applying a graphic

1. Preparation:
 

Mix 1 tablespoon of liquid washing-up detergent with water in a 1qt spray bottle.

Remove the backing from the new graphic and spray both sides and the area of the hull to which it is to be fitted.

### NOTE:

Spraying the front of the graphic will protect it from being scratched during application.

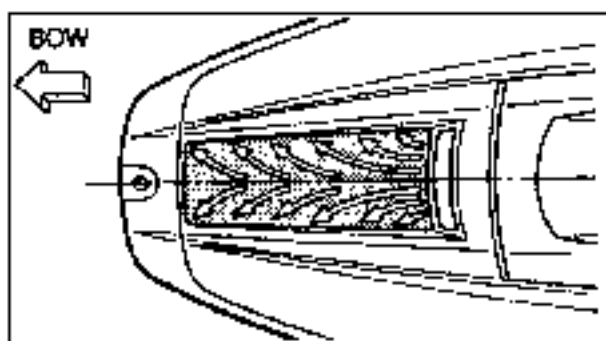

2. Apply:
 

Align the graphic on the fitting area and smooth it into position with a small rubber squeegee, removing all air bubbles in the process. Begin at the top of the graphic and work down and outwards from the center line of the graphic area.
3. Dry:
 

Let the graphic dry in place prior to waxing or using the vehicle.

---

**CHAPTER 9**  
**TROUBLE ANALYSIS**

**TROUBLE ANALYSIS** ..... 9 - 1  
**TROUBLE ANALYSIS CHART** ..... 9 - 1

**TROUBLE ANALYSIS**

**NOTE:**

Following items should be obtained before "trouble analysis".

1. Battery is charged and its specified gravity is in specification.
2. There is no incorrect wiring connection.
3. Wiring connections are surely engaged and without any rust.
4. Lanyard is installed to the engine stop switch.
5. Fuel is coming to the carburetor.

**TROUBLE ANALYSIS CHART**

Trouble mode										Check elements		
ENGINE WILL NOT START	ROUGH IDLING	ENGINE STALLS	ENGINE WILL NOT STOP	POOR PERFORMANCE	OVERHEATING	LOOSE STEERING	BILGE INCREASE	IRREGULAR WARNING INDICATION	POOR BATTERY CHARGING		Relative part	Reference Chapter
<b>FUEL SYSTEM</b>												
<input type="checkbox"/>	<input type="checkbox"/>	<input type="checkbox"/>		<input type="checkbox"/>							Fuel tank	4
<input type="checkbox"/>	<input type="checkbox"/>	<input type="checkbox"/>		<input type="checkbox"/>							Air vent hose	4
<input type="checkbox"/>		<input type="checkbox"/>		<input type="checkbox"/>							Fuel hose	4
<input type="checkbox"/>	<input type="checkbox"/>	<input type="checkbox"/>		<input type="checkbox"/>							Fuel filter	4
<input type="checkbox"/>		<input type="checkbox"/>		<input type="checkbox"/>							Fuel pump	4
<input type="checkbox"/>	<input type="checkbox"/>	<input type="checkbox"/>		<input type="checkbox"/>							Carburetor	4
	<input type="checkbox"/>	<input type="checkbox"/>		<input type="checkbox"/>							Low speed screw setting	4
		<input type="checkbox"/>		<input type="checkbox"/>							High speed screw setting	4
		<input type="checkbox"/>		<input type="checkbox"/>							Carburetor synchronization	4
		<input type="checkbox"/>		<input type="checkbox"/>							Trolling speed	3
<b>POWER UNIT</b>												
<input type="checkbox"/>	<input type="checkbox"/>			<input type="checkbox"/>							Compression	5
<input type="checkbox"/>	<input type="checkbox"/>			<input type="checkbox"/>							Reed valve	5
<input type="checkbox"/>	<input type="checkbox"/>										Cylinder head gasket	5
<input type="checkbox"/>				<input type="checkbox"/>							Piston ring	5
<input type="checkbox"/>				<input type="checkbox"/>							Cylinder block	5
<input type="checkbox"/>				<input type="checkbox"/>							Seal	5
<input type="checkbox"/>				<input type="checkbox"/>							Crank case	5
<input type="checkbox"/>				<input type="checkbox"/>							Piston	5
<input type="checkbox"/>				<input type="checkbox"/>							Bearing	5
<input type="checkbox"/>				<input type="checkbox"/>							Intermediate housing	5
				<input type="checkbox"/>							Coupling	5
				<input type="checkbox"/>							Coupling rubber	5

Trouble mode										Check elements		
ENGINE WILL NOT START	ROUGH IDLING	ENGINE STALLS	ENGINE WILL NOT STOP	POOR PERFORMANCE	OVERHEATING	LOOSE STEERING	BILGE INCREASE	IRREGULAR WARNING INDICATION	POOR BATTERY CHARGING		Relative part	Reference Chapter
					<input type="radio"/>		<input type="radio"/>				Pilot water hose	5
					<input type="radio"/>		<input type="radio"/>				Water hose	5
					<input type="radio"/>		<input type="radio"/>				Water passage	5
<b>JET PUMP UNIT</b>												
				<input type="radio"/>	<input type="radio"/>		<input type="radio"/>				Duct	6
				<input type="radio"/>							Impeller	6
				<input type="radio"/>							Intake screen	6
				<input type="radio"/>							Bearing	6
				<input type="radio"/>							Duct intake	6
					<input type="radio"/>		<input type="radio"/>				Water inlet hose	6
							<input type="radio"/>				Bilge hose	6
							<input type="radio"/>				Bilge strainer	6
							<input type="radio"/>				Bilge hose joint	6
							<input type="radio"/>				Valve body	6
<b>ELECTRICAL</b>												
<input type="radio"/>	<input type="radio"/>	<input type="radio"/>	<input type="radio"/>	<input type="radio"/>	<input type="radio"/>						Ignition system	7
<input type="radio"/>											Starting system	7
								<input type="radio"/>			Indication system	7
									<input type="radio"/>		Charging system	7
<b>HULL AND HOOD</b>												
						<input type="radio"/>					Column bearing	8
				<input type="radio"/>			<input type="radio"/>				Water lock	8
	<input type="radio"/>			<input type="radio"/>			<input type="radio"/>				Exhaust hose	8
				<input type="radio"/>			<input type="radio"/>				Muffler	8
							<input type="radio"/>				Drain plug	8